

Network Standard

NETWORK	Document No	: NW000-S0088
	Amendment No	: 10
	Approved By	: Head of AEP&S
	Approval Date	: 01/10/2020

Minor amendments approved on 05/08/2025

NW000-S0088

NS130 LAYING UNDERGROUND CABLES UP TO AND INCLUDING 11KV



ISSUE

For issue to all Ausgrid and Accredited Service Providers' staff involved with the design and installation of underground cables and conduits, and is for reference by field, technical and engineering staff.

Ausgrid maintains a copy of this and other Network Standards together with updates and amendments on www.ausgrid.com.au.

Where this Standard is issued as a controlled document replacing an earlier edition, remove and destroy the superseded document.

DISCLAIMER

As Ausgrid's Standards are subject to ongoing review, the information contained in this document may be amended by Ausgrid at any time. It is possible that conflict may exist between Standard documents. In this event, the most recent Standard shall prevail.

This document has been developed using information available from field and other sources and is suitable for most situations encountered in Ausgrid. Particular conditions, projects or localities may require special or different practices. It is the responsibility of the local manager, supervisor, assured quality contractor, accredited service provider and the individuals involved to make sure that a safe system of work is employed and that statutory requirements are met.

Ausgrid disclaims any and all liability to any person or persons for anything done or not done, as a result of this Standard.

All design work, and the associated supply of materials and equipment, must be undertaken in accordance with and consideration of relevant legislative and regulatory requirements, latest revision of Ausgrid's Network Standards and specifications and Australian Standards. Designs submitted shall be declared as fit for purpose. Where the designer wishes to include a variation to a Network Standard or an alternative material or equipment to that currently approved the designer must obtain authorisation from the Network Standard owner before incorporating the variation to a Network Standard or alternative material into a design. All designers including external designers authorised as Accredited Service Providers will seek approval through the approved process as outlined in NS181 Approval of Materials and Equipment and Network Standard Variations. Seeking approval will ensure Network Standards are appropriately updated and that a consistent interpretation of the legislative framework is employed.

Notes: 1. Compliance with this Network Standard does not automatically satisfy the requirements of a Designer Safety Report. The designer must comply with the provisions of the Work Health and Safety Regulation 2017 (NSW - Part 6.2 Duties of designer of structure and person who commissions construction work) which requires the designer to provide a written safety report to the person who commissioned the design. This report must be provided to Ausgrid in all instances, including where the design was commissioned by or on behalf of a person who proposes to connect premises to Ausgrid's network, and will form part of the Designer Safety Report which must also be presented to Ausgrid. Further information is provided in Network Standard (NS) 212 Integrated Support Requirements for Ausgrid Network Assets.

2. Where the procedural requirements of this document conflict with contestable project procedures, the contestable project procedures shall take precedent for the whole project or part thereof which is classified as contestable. Any external contact with Ausgrid for contestable works projects is to be made via the Ausgrid officer responsible for facilitating the contestable project. The Contestable Ausgrid officer will liaise with Ausgrid internal departments and specialists as necessary to fulfil the requirements of this Standard. All other technical aspects of this document which are not procedural in nature shall apply to contestable works projects.

INTERPRETATION

In the event that any user of this Standard considers that any of its provisions is uncertain, ambiguous or otherwise in need of interpretation, the user should request Ausgrid to clarify the provision. Ausgrid's interpretation shall then apply as though it was included in the Standard, and is final and binding. No correspondence will be entered into with any person disputing the meaning of the provision published in the Standard or the accuracy of Ausgrid's interpretation.

KEYPOINTS

This Standard has a summary of content labelled "KEYPOINTS FOR THIS STANDARD". The inclusion or omission of items in this summary does not signify any specific importance or criticality to the items described. It is meant to simply provide the reader with a quick assessment of some of the major issues addressed by the Standard. To fully appreciate the content and the requirements of the Standard it must be read in its entirety.

AMENDMENTS TO THIS STANDARD

Where there are changes to this Standard from the previously approved version, any previous shading is removed and the newly affected paragraphs are shaded with a grey background. Where the document changes exceed 25% of the document content, any grey background in the document is to be removed and the following words should be shown below the title block on the right hand side of the page in bold and italic, for example, Supersedes – document details (for example, "Supersedes Document Type (Category) Document No. Amendment No.>").

KEY POINTS OF THIS STANDARD

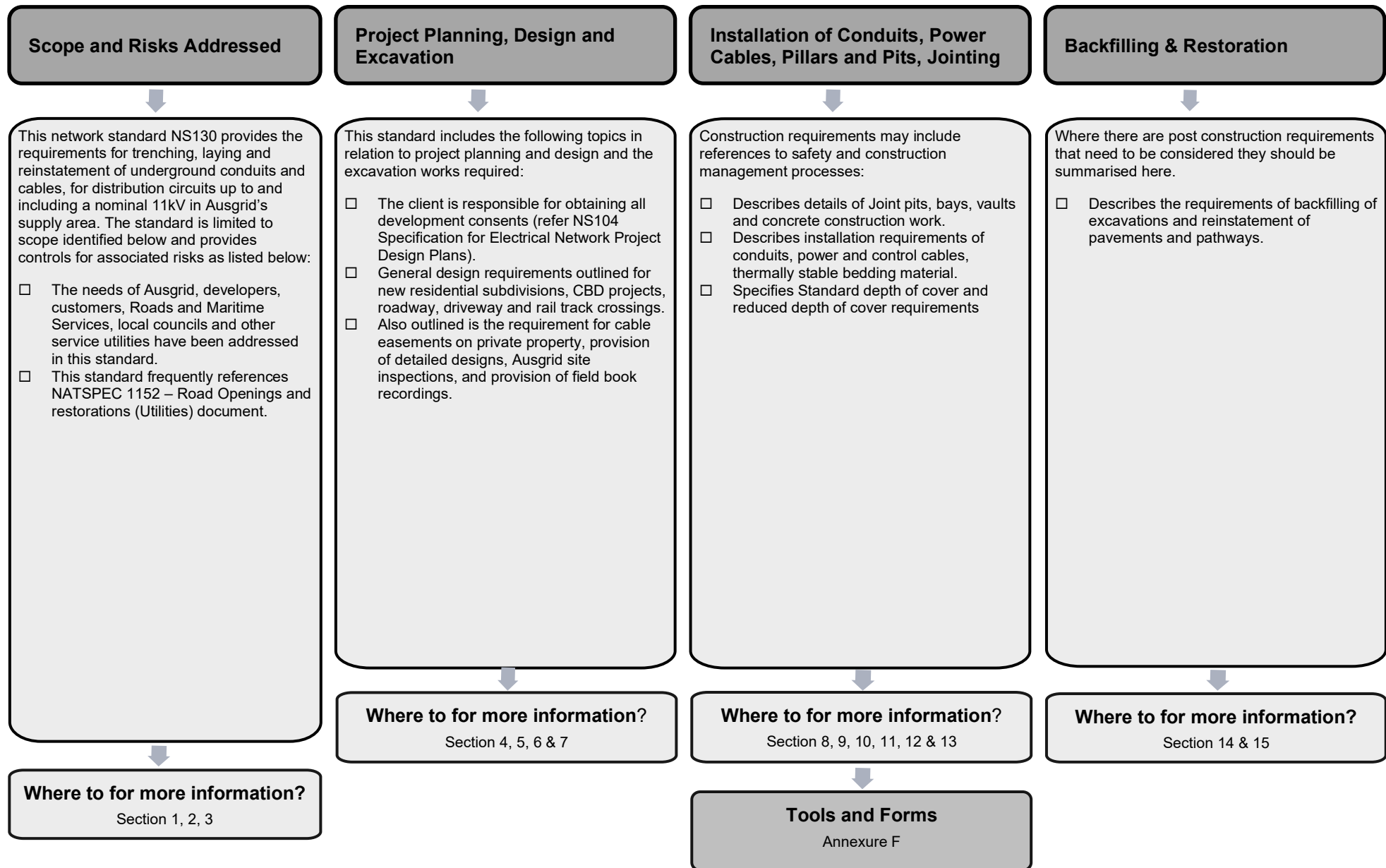

Network Standard NS130 Laying Underground Cables up to and including 11kV

Contents

1.	PURPOSE	8
2.	SCOPE	8
3.	NATSPEC 1152.....	8
4.	PROJECT PLANNING AND DESIGN.....	8
4.1	General	8
4.2	New residential subdivisions	8
4.3	Central business district (CBD) projects	8
4.4	Roadway crossings	9
4.5	Driveway crossings	9
4.6	Railway track crossings.....	9
4.7	Trenchless technology	9
4.8	Private mains.....	9
4.9	Ausgrid’s cables in easements on private property	9
4.10	Provision of detailed design by the client.....	10
4.11	Inspection by Ausgrid	10
4.12	Provision of field book recordings and survey plans.....	10
	4.12.1 Field recording of network assets	10
	4.12.2 Survey plan (red line plan).....	10
4.13	Registration of easement	10
4.14	Installation of cables under waterways	10
4.15	Proximity to 132kV, 66kV and 33kV Ausgrid Cables	11
5.	SETTING OUT OF EXCAVATIONS.....	11
5.1	General	11
5.2	Additional work	11
5.3	Shared trenching agreements.....	11
5.4	Dimensions of trenches.....	12
5.5	Pegging of easements.....	12
5.6	Set out for excavations in new subdivisions	12
5.7	Set out for excavations in established areas	13
6.	EXCAVATION OF TRENCHES AND OTHER SITES.....	14
6.1	General	14
6.2	Removal of pavement layers in established areas	14
6.3	Locating existing services	14
6.4	Precautions.....	14
6.5	Excavation of trenches	14
6.6	Excavation of joint holes.....	15
6.7	Excavation of substation sites	15
7.	BREAKING INTO AND REMOVAL OF CONCRETE ENCASED CONDUITS	15
8.	JOINTING PITS	16

- 8.1 Removal and/or reconstruction of existing jointing pits containing cables/conduits 16
- 8.2 Construction of jointing pits 16
 - 8.2.1 General 16
 - 8.2.2 Additional penetrations in cable pits 16
- 9. CONCRETE CONSTRUCTION WORK 17
 - 9.1 General 17
 - 9.2 Site mixed concrete 17
 - 9.3 Ready mixed concrete 18
 - 9.4 Concrete construction 18
- 10. INSTALLATION OF CONDUITS 20
 - 10.1 General conduit requirements 20
 - 10.2 Approved conduits 20
 - 10.3 Storage of conduits 21
 - 10.4 Coupling of conduits 22
 - 10.5 Conduit bends 22
 - 10.6 Installation of telecommunication conduits 22
 - 10.7 Sealing of conduits 23
 - 10.8 Laying of conduits 23
 - 10.9 Banks of conduits 23
 - 10.10 Standard conduit and cable spacings 23
 - 10.11 Standard depth of cover 24
 - 10.12 Reduced depth of cover 28
 - 10.13 Bedding types 31
 - 10.14 Concrete encased conduits 32
 - 10.14.1 General 32
 - 10.14.2 Plastic conduit spacers 34
 - 10.15 Sand/cement bedding of banks of conduits 34
 - 10.15.1 Sand/cement bedding 34
 - 10.15.2 Construction procedure 34
 - 10.16 Standard bedding of banks of conduits 34
 - 10.16.1 Standard bedding material 34
 - 10.16.2 Construction procedure 34
 - 10.17 Procedure for dry bedded banks of conduits 34
 - 10.18 Protection of conduits 35
 - 10.19 Use of warning tape 36
 - 10.20 Inspections by Ausgrid 36
 - 10.21 Kerb marking 36
 - 10.22 Bridge crossings 36
- 11. THERMALLY STABLE BEDDING MATERIAL 37
 - 11.1 General 37
 - 11.2 Approved materials and mix design 37
 - 11.3 Default slurry mix 38
 - 11.3.1 General 38
 - 11.3.2 Installation of thermally stable slurry mixes 39
 - 11.4 Dry mix 40
 - 11.5 Alternative TSB materials 40
 - 11.6 Minimum coverage of thermally stable bedding 40
 - 11.7 Testing 40
- 12. INSTALLATION OF PILLARS AND RAG-BOLT ASSEMBLIES FOR STEEL LIGHTING POLES 41
 - 12.1 Installation of pillar bases 41

12.2	Installation of rag bolt assemblies for steel lighting poles	42
13.	INSTALLATION OF POWER AND CONTROL CABLES.....	43
13.1	General requirements.....	43
13.1.1	Pilot Cables.....	43
13.2	Testing of conduits prior to use	44
13.3	Direct buried cables.....	44
13.3.1	General	44
13.3.2	Standard cable spacing	45
13.3.3	Standard depth of cover for direct buried cables.....	45
13.4	Sealing of cables	45
13.4.1	General	45
13.4.2	Method of sealing.....	45
13.4.3	Safety precautions and first aid procedures for graphite coated cables	46
13.5	Shorting of cable cores.....	46
13.5.1	Multicore cables	46
13.5.2	Single core neutral screened low voltage cables	47
13.5.3	Single core low voltage polymeric cables 185 mm ² and 300 mm ²	47
13.5.4	Single core copper wire screened high voltage cables	47
13.5.5	Single core metallic sheathed PILC cables	47
13.5.6	11kV UGOH terminations	47
13.6	Cable length and joints.....	47
13.6.1	General	47
13.6.2	Placement of cable joints near road crossings.....	48
13.6.3	Joints within the Cable Basement of Zone Substation Buildings	48
13.7	Joint bays	49
13.8	Damage to cables during construction.....	49
13.9	Bending radii of cables	49
13.10	Cable pulling equipment.....	52
13.11	Use of existing spare conduits	53
13.12	Excavations and cable chases.....	53
13.13	Cable installations involving jointing pits.....	53
13.14	Installing cables in substations and switching stations	54
13.14.1	General	54
13.14.2	Cable labelling	54
13.14.3	Installing cables in kiosk type substations	55
13.15	Installing cables in cable risers	56
13.16	Clamping of 11kV paper insulated cables.....	57
13.17	Clamping of 11kV polymeric insulated cables	57
13.18	Underground to overhead transition points.....	60
13.19	Standard depth of cover	60
13.20	Reduced depth of cover	60
13.21	Installation of underground cables in the vicinity of poles.....	60
13.22	Clearance to other utility services	60
14.	BACKFILLING OF EXCAVATIONS.....	61
14.1	Backfill material	61
14.1.1	General	61
14.1.2	Roads and Maritime Services requirements.....	61
14.1.3	Additional Ausgrid requirements.....	61
14.2	Backfill in landscape areas.....	61
14.3	Backfill to subgrade level under footpaths, carriageways and heavy duty driveways	61
14.4	Compaction of trench backfill	61

14.5 Disposal of surplus materials 61

14.6 Record keeping requirements 61

14.7 Testing of conduits 62

15. REINSTATEMENT OF PAVEMENTS AND PATHWAYS 63

15.1 Temporary reinstatement 63

15.1.1 Reinstatement requirements 63

15.1.2 Temporary steel road plates 63

15.1.3 Road furniture 63

15.2 Final reinstatement 63

16. FREQUENCY OF TESTING OF BACKFILL AND TEMPORARY RESTORATIONS 64

17. CABLE JOINTING 65

18. CABLE TESTING REQUIREMENTS 65

19. PROTECTION OF EXPOSED UNDERGROUND CONSTRUCTION 66

20. CABLE TUNNELS 66

20.1 Shared Cable Tunnels 66

21. STORES AND MATERIALS 67

22. AUTHORITIES AND RESPONSIBILITIES 68

23. RELATED DOCUMENTS 68

23.1 Ausgrid documents 68

23.2 Other standards and documents 69

23.3 Acts and regulations 70

24. DEFINITIONS 71

25. RECORDKEEPING 71

26. DOCUMENT CONTROL 71

ANNEXURE A – LIST OF DRAWINGS 72

ANNEXURE B – TYPICAL TRENCH DIMENSIONS 74

ANNEXURE C – TYPICAL CABLE ARRANGEMENTS IN FOOTWAYS 75

ANNEXURE D – FOOTWAY ALLOCATIONS 80

ANNEXURE E – GUIDE TO MAXIMUM PULLING TENSIONS 82

ANNEXURE F – GUIDE TO CALCULATING CABLE PULLING TENSION 85

ANNEXURE G – STOCKCODES OF APPROVED ITEMS 90

ANNEXURE H – CBD 16 WAY CONDUIT LINE 94

ANNEXURE I – TYPICAL FINAL RESTORATIONS 95

ANNEXURE J – INSTALLATION OF NETWORK CONDUIT LINES THROUGH BUILDINGS 97

ANNEXURE K – TESTING OF BACKFILLS: THERMAL RESISTIVITY 101

ANNEXURE L – TYPICAL TSB RECIPES 109

1. PURPOSE

This Network Standard provides the requirements for trenching, laying and reinstatement of underground conduits and cables, for distribution cables up to and including 11kV in Ausgrid's network.

2. SCOPE

This Network Standard specifies the requirements for Trenching, Laying Conduits and Reinstatement that have been established to meet the particular needs of Ausgrid, developers, customers, Roads & Maritime Services (RMS), local councils and other service utilities.

Refer to NS168 for underground sub-transmission cables above 11kV.

3. NATSPEC 1152

This Network Standard frequently refers to the 1152 document which is an industry specification dealing with road openings and restoration. It is managed by NATSPEC, and supersedes AUS-SPEC#2, 306U, which was previously used in this regard.

The method used in this Network Standard to call up a specified Clause in the NATSPEC 1152 document is as follows, 1152.1.10 Subheading where 1.10 is the section number and Subheading is the title of the relevant paragraph (generally a bold heading in 1152) if necessary.

A copy of the NATSPEC 1152 - Road Openings and Restorations (Utilities) document is available from NATSPEC via their website.

4. PROJECT PLANNING AND DESIGN

4.1 General

The Client must comply with the requirements of Ausgrid's Network Standard NS104, Specification for Electrical Network Project Design Plans. Attention is drawn to Section 5 of that Network Standard, regarding responsibility for obtaining consent from other parties. The Client must comply with any special requirements of other authorities.

4.2 New residential subdivisions

In new residential subdivisions, the electricity network shall generally be installed underground in accordance with Ausgrid's current Network Standards (refer to document 'Policy for ASP/1 Premises Connections' clause 6.3 Infrastructure Design, for overhead and underground policy details). The Client is responsible for the reticulation of the subdivision in accordance with Ausgrid's document Connection Policy, which provides for contestability of customer connections and some system augmentation.

4.3 Central business district (CBD) projects

HV and LV cable installations in Sydney's Central Business District are generally pit and duct (pit and conduit) configurations. Specific details relating to conduit configuration, number, size etc depend on the purpose of the project and shall be provided on a project-by-project basis.

Where obstructions of service congestion prevent the installation of a ductline in accordance with Annexure H, the matter shall be referred to the designer for advice. Alternatives such as constructing a 5 x 3 ductline may be considered.

4.4 Roadway crossings

All distribution cables shall be laid in approved conduits across or along roadways to allow for future system alterations/augmentations with minimal civil works. Refer to Section 10 for construction requirements. Additional spare conduits in roadway crossings may also be required by Ausgrid. This will be specified on the Design Information.

Due to the requirements of certain Roads Authorities (e.g. RMS and Local Councils), open trenching across certain roadways and other public thoroughfares may not be permitted without specific approval. Refer to Clause 4.7 Trenchless Technology.

Once an installation is completed, all conduits shall be tested in accordance with Clause 13.2 Testing of Conduits.

4.5 Driveway crossings

Where a cable route crosses concrete formed or paved driveways, special precautions shall be taken to ensure minimal damage to such driveways. Trenchless methods of crossing these driveways shall be considered to minimise the impact of cable laying on the local community, and to reduce the overall cost of cable laying.

Once an installation is completed, all conduits shall be tested in accordance with Clause 13.2 Testing of Conduits.

4.6 Railway track crossings

An agreement must be obtained from the appropriate railway authority.

All new rail crossings (overhead or underground) should allow for all poles or the ends of conduit banks to be located OFF rail property.

Poles must be located in the road reserve either side of a rail crossing, provided Rail's technical requirements on maximum span lengths etc permit this.

Conduits must be run the full width of the rail corridor, finishing just outside the rail property boundary, so that the need to enter rail land for works is minimised. The cable installation across the railway tracks shall be made by trenchless methods in accordance with the requirements of the Rail Authority concerned. Note that a bore across the entire width of rail land may not be necessary.

Where new works on existing crossings permit, the opportunity to extend conduit banks or relocate poles should be considered.

4.7 Trenchless technology

For information on using trenchless technologies refer to NS159 Installation of Cables and Conduits using Trenchless Techniques.

4.8 Private mains

Private mains shall not be installed in Ausgrid's electricity footway allocation. (i.e. privately owned streetlighting circuits).

4.9 Ausgrid's cables in easements on private property

Where Ausgrid's cables are to be installed on private property with the substation lease/easement site set back from the street alignment, excluding the Sydney CBD;

- The cables should be installed in conduit for the full length of the easement unless the cable route dictates otherwise; e.g. excessive conduit bends and/or jointing requirements.
- One spare conduit for each cable shall be installed at depth of cover appropriate for the cable voltage.
- The cable route along the easement shall be marked in accordance with the requirements of NS143.

- The installed conduits/cables must be surveyed to capture the correct installed location over the entire length of the easement. For contestable projects, this survey shall occur prior to electrification.

4.10 Provision of detailed design by the client

In accordance with the requirements of the Ausgrid publication, Contract for Design Related Services, the Client must submit completed designs to Ausgrid for certification prior to commencing construction.

The designs must be professional, detailed and site specific and must include details of the calculated cable pulling tensions. Annexure F is a guide to calculating cable pulling tension.

The designer shall ensure that the cable route is fully located within Ausgrid's allocation at standard cover.

4.11 Inspection by Ausgrid

Ausgrid will carry out an appropriate level of site inspection during the construction phase to ensure that the network assets, including cables and conduits, are being constructed in accordance with the certified design, Ausgrid's Network Standards, Policies and Safety requirements.

Unforeseen site conditions requiring a variation or design change must be documented and referred to the designer for amendments to the design approval and re-certification as required.

4.12 Provision of field book recordings and survey plans

4.12.1 Field recording of network assets

Information regarding the construction, modification, repair, and/or retirement of Ausgrid's network assets must be recorded in accordance with NS100 - Field Recording of Network Assets. These records must be submitted to the Data Maintenance team in accordance with NS100.

4.12.2 Survey plan (red line plan)

Where cables or substations are to be located on private property, a survey (lease/easement) plan is required in order to establish easements or a lease to cover the electrical works. A copy of this plan is to be provided to Ausgrid showing the following additions in red ink:

- (a) The centreline of electricity cables (or cable conduits if used) with offsets to the easement boundaries.
- (b) The location of the substation and associated access and ventilation facilities if not already shown on the original plan.
- (c) Signature by the Registered Surveyor with an accompanying statement to certify that the information shown in red ink has been accurately located to their satisfaction.

4.13 Registration of easement

Refer to the following documents,

- Policy for ASP/1 Premises Connections - Clause 2.3, Leases and Easements as well as Section 10, The Connection Process, Stage 16.
- Model Standing Offer – Standard Connections Services for Contestable ASP/1 Premises Connections no greater than 11kV – Clause 4 & Clause 5
- NS143 Easements, Leases and Rights of Way

4.14 Installation of cables under waterways

Cable installation under waterways (e.g. creeks, rivers, bays) is a special project and designs should be carried out on case by case basis. These designs must be submitted to Ausgrid for certification prior to commencing construction and must also conform to the requirements of the local maritime, waterways, fisheries, environment and/or heritage authority. If a trenchless

technique is used for cable installation under waterways (e.g. creeks, rivers) the installation of cables and conduits shall comply with the requirements of NS159.

Any waterway crossings associated with navigable waterways administered by NSW Roads and Maritime Services (RMS) must comply with AS6947 Crossing of Waterways by Electricity Infrastructure, the Crossings of NSW Navigable Waters: Electricity Industry Code.

All waterway crossings must be risk assessed in accordance with a methodology approved by Ausgrid. Ausgrid employees should refer to NEG OH14 – Guide to the Assessment of Waterway Crossing Risk.

4.15 Proximity to 132kV, 66kV and 33kV Ausgrid Cables

All cables up to and including 11kV, that come within 4m of the edge of existing or proposed 132kV, 66kV or 33kV underground cables shall have a rating assessment completed by the designer in accordance with NS272, and the rating assessment shall be submitted to Ausgrid for review and approval.

5. SETTING OUT OF EXCAVATIONS

5.1 General

The limits of the proposed excavation for trenches, pits and kiosk sites must be set out in accordance with an Ausgrid approved Certified Design/Design Plan, this Network Standard, and NATSPEC 1152.

Trenches in footways which have been or will be dedicated to public use, are to be excavated in the space allocation dedicated for Electric Cables, as defined in Annexure D, except where agreements are entered into for the sharing of trenches.

It should be noted that streets in the Sydney Metropolitan area that were dedicated prior to 1 January 1991 have different footway allocations to those dedicated after 1 January 1991. New underground electricity work in streets dedicated before 1 January 1991 shall comply with the original footway allocations (i.e. those applying before 1 January 1991).

The electricity allocation in state roads shall be in accordance with the requirements of the NSW Streets Opening Coordination Council (SOCC) Guide to Codes and Practices for Streets Opening.

For minimum separation distances between Utility services, refer to NSW Streets Opening Coordination Council (SOCC) Guide to Codes and Practices for Streets Opening.

The Client shall give appropriate notice to Ausgrid to allow inspection and approval of the set out prior to commencing work.

5.2 Additional work

Local Council may request additional removal and restoration works beyond the scope of works approved by Ausgrid (see 1152.3.3):

- If the additional work is deemed non-contestable, such work will be identified and defined by Ausgrid in negotiation with the Local Council's Restoration Officer.
- If the additional work is contestable work, the Client shall consult with the Local Council's Restoration Officer concerning Council's requirements and shall make these details available to Ausgrid's Representative.

5.3 Shared trenching agreements

Ausgrid has 2 separate trench sharing agreements for new installations.

The first agreement is between The Electricity Supply Association of Australia and Australian Post Office, and it was historically the default arrangement adopted. Trenching details of this agreement are detailed in Annexure C. Where this agreement is invoked, all Telecommunication assets must be in 0 - 300mm allocation from the property boundary. This can only be used in streets dedicated prior to 1991.

The second agreement is between AGL, EnergyAustralia, Optus and Telstra “Underground Services in a Shared Trench (NSW 1998)”. This agreement will only be considered by Ausgrid for new underground developments that consist of newly dedicated roads where no other underground services exist.

Where shared trenching is proposed under this agreement, Ausgrid’s approval must be obtained and a shared trench agreement must be entered into in accordance with the “Underground Services in a Shared Trench (NSW 1998)” agreement between AGL, EnergyAustralia, Optus and Telstra (available on request from Ausgrid).

Note: No utility service shall be installed on top of any Ausgrid’s services - to allow future access. A minimum of 100mm horizontal separation is required unless otherwise approved by Ausgrid.

No utility service shall be within 100mm of a low voltage cable or 300mm of a high voltage cable.

Recording details of the project shall clearly define the start and finish points of the shared trench, its dimensions and the service utilities involved (sectionalised if necessary to indicate the presence or absence of certain utilities).

5.4 Dimensions of trenches

The trench size depends on the following factors:

- Number and type of cables
- Number and nominal size of conduits
- Location of trench (i.e. footpath or roadway)
- Any shared trenching arrangements agreed to with other utilities.

Unless otherwise specified, or changes have been approved by Ausgrid, the guidelines for trench dimensions given in Annexure B, and the cable layouts shown in Annexure C must be used.

5.5 Pegging of easements

The location of the easement shall be pegged by a Registered Surveyor prior to commencement of excavation work. If the pegs or marks made by the Surveyor have been disturbed or removed, excavation shall not commence until the pegs or marks have been re-established. The only time re-establishment of the pegs may not be required is if the easement boundaries have been thoroughly marked subsequent to the Surveyor pegging them, and those boundary markings are sufficient to permit the trench to be excavated and recorded relative to the easement boundaries. If it is necessary to locate any part of the trench outside the planned easement boundaries due to other obstructions, then the extent of the diversion must be clearly marked and the markings preserved until the Surveyor can return to adjust the plan.

Final ground level shall be marked on all pegs.

5.6 Set out for excavations in new subdivisions

These requirements apply to all installations in dedicated public roadways/footways and subdivisions intended to be dedicated as such.

In new subdivisions, the Client (or developer) must indicate the subdivision lot boundaries and street alignment by installing pegs either at the street alignment or at a nominated distance from that alignment (offset recovery pegs) before any excavation work takes place. Pegs showing final footpath level must also be provided by the Client. In cases where footways are elevated above the kerb and gutter level, the roadway surface near the footway will be accepted as the future final level. Pegs must be clearly visible, easily identified and undisturbed after trench excavation to facilitate accurate positioning and recording of assets.

The Client is responsible for the correct positioning of all cable trenches. Trenches in footways that have been or will be dedicated to public use are to be excavated in the Ausgrid space allocations as specified in Annexure D.

If it is necessary to occupy part of the footway usually allocated to another Authority, or part of the roadway for laying cables, the Client must first obtain the approval of Ausgrid followed by the written approval of the other Authority – or local council or road owner - before construction work commences. Road crossings and crossings of other Authorities' allocations must be at 90° to the property alignment, unless written approval is obtained from Ausgrid.

5.7 Set out for excavations in established areas

The Client shall set out the limits of the proposed excavation for trenches, pits and chambers using chalk or crayon to be readily understandable but without permanently defacing any surface. The set out shall minimise damage to existing surfaces.

To minimise or eliminate residual small portions of paving slabs, the set out shall be adjusted as necessary. Any adjustments will be with respect to the existing paved surfaces and joint patterns. Adjustments shall generally be in accordance with the following guidelines, and must be approved by Ausgrid before construction commences:

(a) Pathways

- (i) The set out line shall be varied in accordance with the reinstatement requirements of the NSW Streets Opening Coordination Council (SOCC) Guide to Codes and Practices for Streets Opening.
 - Bitumen and Concrete Paving - In accordance with the reinstatement provisions and sketches of the NSW Streets Opening Coordination Council (SOCC) Guide to Codes and Practices for Streets Opening.
 - Segmental Paving Units - The set out line shall be at least one whole unit clear of both sides of the minimal alignment of the trench.
 - Textured or Patterned Concrete - The set out line shall enable an aesthetically acceptable restoration of the pavement as approved by Ausgrid.
- (ii) Where Ausgrid directs that certain driveways are not to be disturbed, services under these driveways shall be installed by trenchless technology where suitable and no other services are present. A risk assessment must be completed by the Constructor to ensure no damage can occur to other services if trenchless technology is to be utilised.

(b) Carriageways

- (i) In asphalt pavements, the trench set out shall be at minimum width, and wherever possible, shall be at right angles to the street alignment.
- (ii) In concrete pavements, the advice of the appropriate road authority and/or professional engineering advice shall be sought regarding the location of trench set-out lines.
- (iii) Any trench or surface work proposed in the vicinity of Permanent or State Survey Marks shall be referred to the Land Information Centre of the Department of Lands, prior to commencement of Work, to obtain protection or relocation requirements.

Refer to 1152.3.6 for further information.

6. EXCAVATION OF TRENCHES AND OTHER SITES

6.1 General

Excavation work shall be carried out with minimal disturbance to the surrounding environment and in accordance with the requirements of the relevant Local, State, and Federal authorities (e.g. SafeWork NSW Codes of Practice, Safe Work Australia).

All excavations shall be excavated according to Ausgrid's standard widths and depths as specified in the Certified Design/Design Plan, Network Standards and/or other engineering/design drawings approved by Ausgrid.

Before conduit or cable laying commences, the excavated trench must be inspected by a Representative of Ausgrid.

6.2 Removal of pavement layers in established areas

In removing surface and sub-surface materials, maximum care shall be exercised to safeguard existing underground services and other structures within and around the work site against damage. The guidelines in 1152.3.5 shall be adhered to unless otherwise specifically approved by Ausgrid.

6.3 Locating existing services

The Constructor performing the excavation is responsible for locating all existing services that may be affected by the proposed works before any excavations take place. This includes contacting the designated underground asset information provider.

NATSPEC1152.3.6 Existing services, should be referred to for information on working in the vicinity of other utilities, along with the SafeWork NSW Work Near Underground Assets - Guide.

6.4 Precautions

All cables and conduits detailed in underground plans in the vicinity of the proposed works must be exposed. Excavations must be cleared of spoil to a minimum of 200mm around any cable covers, joints, cables or conduits.

The persons carry out the works shall also observe the requirements of Network Standard NS156 Working Near or Around Underground Cables with regards to the safety aspects of working in close proximity to underground cables.

When cutting cable covers or conduits, appropriate controls must be put in place to avoid creating a hazardous condition through the contact with live cable.

Where existing cables have been exposed and found to be non-compliant with the standard depth of cover in Table 3 and the reduced cover and backfill requirements in Table 4, Ausgrid's Representative shall be notified. The protection requirements of Table 4 should be retrospectively implemented. Where these protection requirements are impractical to implement, as a minimum, steel plates shall be installed across the full width and length of the exposed trench, above the existing cables' bedding. Details of reduced cover and backfill on existing cables shall be provided to Ausgrid as part of field book recording to enable updating asset records in Ausgrid's Geographic Information System (GIS) see Clause 4.11.

Where it is found in URD areas where driveways have been lowered so that the initial standard cover (Clause 10.11) has been reduced, the owner of the property serviced by the driveway shall be asked to meet reduced cover requirements or restore the cover to the original level.

6.5 Excavation of trenches

Trenches shall be kept as straight as possible, and the bottom of an open trench shall be firm and smooth, free of rocks, pebbles, foreign matter and sharp projections. Where trenches pass from footway to roadway and a change of level is necessary, the rise and fall shall be gradual.

If the excavated material is considered by Ausgrid to be unsuitable for re-use as backfill, the material shall be removed and disposed of as specified in 1152.3.6 Unsuitable material / Contaminated or hazardous material. Unsuitable backfill materials include building materials (e.g.

concrete, bricks, pavers, rocks, roofing tiles, rubble), contaminated substances (including Hazardous Materials) and other materials that cannot achieve the required compaction (e.g. heavy clays).

If the excavated material meets the requirements of Section 14 and additionally is considered suitable by Ausgrid, the excavated material shall be reused in backfilling operations. Stockpiling of suitable excavated material shall be in accordance with NS174 and 1152.3.6 Excavated material stockpiles.

Safe and direct access to substations must not be impeded by excavation works.

6.6 Excavation of joint holes

Exposed joints and cables in joint holes must be supported at one-metre intervals and protected against damage or failure.

Open joint holes must be securely fenced off in accordance with the approved traffic management plan and Work Health & Safety requirements.

Open joint holes (including trenches or excavations) containing existing assets must not be left open or unattended unless appropriate precautions have been taken to secure and prevent unauthorised access to the excavation and Ausgrid assets (e.g. secured fencing, road plates or similar).

6.7 Excavation of substation sites

The excavation and foundation requirements for substation sites are detailed in the following Network Standards:

- NS117, Design and Construction Standards for Kiosk Type Substations
- NS141, Site Selection and Site Preparation Standards for Kiosk Type Substations
- NS165, Safety Requirements for Non-Electrical Work in and Around Live Substations.

7. BREAKING INTO AND REMOVAL OF CONCRETE ENCASED CONDUITS

The specified strength for concrete which encases conduits in roadways, including those in the Sydney Central Business District ('the City') is 3 to 5MPa. However, some conduits have been encased in concrete with strength well above 5MPa. Tests have identified 35MPa concrete in some conduit installations. Concrete above about 3MPa is difficult to break into without using power tools.

Conduits normally contain cables, some or all of which could be energised. When breaking into such conduits, extreme care must be taken to avoid creating hazardous conditions to personnel, and damage to equipment and loss of supply.

The persons carrying out the works shall consult with Ausgrid as to the options available for minimising the risks involved, such as de-energising live cables and/or removing cables from the conduits concerned.

In many circumstances it will not be reasonably practicable to de-energise or remove cables from a conduit, so some cables may have to remain energised while concrete is being stripped. Under these circumstances a procedure designed to minimise any risk of electric shock or flash burns to the staff involved and the general public shall be prepared by the persons carrying out the works and submitted to Ausgrid for review prior to any such work taking place. The procedure shall be:

- developed by a competent person, who has acquired through training, qualification or experience, the knowledge and skills to carry out this task; and
- carried out by competent persons having regard to the nature of the work, the nature of the risks associated with the work, and the control measures implemented.

The procedure shall also safeguard Ausgrid's assets against any mechanical damage. The persons carrying out the works shall be responsible for the costs associated with working to an approved procedure and for any damage caused.

Some of the existing conduits and troughing are made of asbestos cement and appropriate asbestos handling methods shall be used.

8. JOINTING PITS

8.1 Removal and/or reconstruction of existing jointing pits containing cables/conduits

Prior to commencing any demolition or reconstruction of existing jointing pit which contains cables or conduits, special precautions must be taken to protect the cables and any joints involved against mechanical damage.

It is critical that existing cables/conduits and associated joints are not disturbed unless specific written approval has been obtained from Ausgrid to the contrary.

All cables and associated joints in a pit that is undergoing demolition and/or reconstruction work shall be supported and protected using non-conductive structures. These structures shall be mechanically capable of supporting the cables and associated joints.

Cables shall be secured to the horizontal member of the supporting structures with non-metallic fixings at no more than 1500mm intervals. Joints shall be supported at both ends of the joint. The supported cables and joints are to be enclosed in fibre reinforced non-conductive troughings. Protective Mats (Refrasil mats) shall then be draped over the enclosed cables and supports and secured to prevent dislodgment.

Prior to removing the roof/lid of a jointing pit the Constructor shall place timber sheeting to fully cover all cables and joints to prevent damage by falling materials.

8.2 Construction of jointing pits

8.2.1 General

Construction of jointing pits shall be carried out in accordance with detailed drawings and information prepared in accordance with NS172 Design Requirements for Cable Jointing Pits and Vaults.

Precast concrete jointing pits are acceptable for use in appropriate applications. Refer to NS 172 and Ausgrid Drawing No. 249060, noting that this drawing provides typical pit details for use in the development of site specific cable pit designs.

8.2.2 Additional penetrations in cable pits

Prior to core drilling, sawing or penetrating the structure of a cable pit a structural assessment shall be conducted.

Additional penetration locations shall consider the effects for personnel access and egress and must not impede this access or egress when cable is installed in these penetrations.

The structural assessment shall include but not be limited to the following:

- the impact the proposed works have on structural integrity
- strengthening required (if applicable)
- corrosion protection
- method of waterproofing the penetration.

Structural assessment shall be coordinated through Ausgrid's Development Services Section.

Bell-mouths must be installed as per Clause 10.8.

9. CONCRETE CONSTRUCTION WORK

9.1 General

All concrete shall be in accordance with the requirements of AS3600.

(a) Cement

Cement shall be Type GP general purpose Portland cement or equivalent complying with AS3972. If requested by Ausgrid, a Certificate of Compliance with the requirements of the Australian Standard shall be provided.

(b) Fine aggregate

Fine aggregate shall be approved washed river sand or Sydney Hill Sand having clean, sharp, hard, durable grains, uniform in quality and free from harmful amounts of soft or flaky particles, dust, lumps, loam, clay, slag, organic or other deleterious substances. The material shall comply with AS2758.1.

(c) Coarse aggregate

Coarse aggregate shall comply with AS2758.1 and shall be approved crushed blue metal or washed river gravel, of 20mm gauge, graded to 6mm, uniform in quality having clean, hard, durable, uncoated particles, and free from flat, thin or elongated pieces of dust, organic or other soluble or deleterious substances. Brecciated aggregates shall not be used.

(d) Testing of aggregates

Testing of aggregates to AS1141 shall be at the discretion of Ausgrid.

(e) Water

Water shall comply with the provisions of AS3600.

(f) Reinforcement

Reinforcement shall be either steel bars complying with AS4671 or hard drawn steel wire fabric complying with AS4671. Reinforcement shall be accurately cut to size and bent to shape and shall be free from scale, oil and loose rust.

Reinforcement shall be stored to prevent deterioration due to rust or any other cause.

9.2 Site mixed concrete

Concrete mixing carried out on site shall be by rotating batch mixers only, unless specifically approved on a site by site basis.

The aggregates shall be gauged with approved gauge boxes only. Gauging by shovels is not permitted.

Water shall also be measured using approved containers or other approved means.

Measured batches shall be thoroughly mixed together in a rotating batch mixer for at least two minutes after all materials (including water) have been added and before any part of the batch is discharged. A suitable timer shall be used to ensure sufficient mixing time.

The batch mixing drum of the rotating mixer shall be thoroughly emptied, and cleaned immediately before and after each batch.

(a) Trial mixes

If required by Ausgrid, the correct proportions of water, cement and fine and coarse aggregates shall be determined by trial mixes, and the proportions shall be adjusted to suit the available aggregates and placing conditions. Preliminary test results of the trial mixes shall be submitted to Ausgrid for approval before any concrete is poured.

9.3 Ready mixed concrete

Ready-mixed concrete from an approved central mixing plant will be acceptable provided that both its use and properties comply with AS1379. The testing requirements of AS1379 shall be additional to those of AS3600.

The method of ordering ready mixed concrete shall be as described in AS1379.

9.4 Concrete construction

(a) Formwork

Formwork shall comply with AS3610. Forms shall conform to the shapes, lines and dimensions shown on the drawings. All forms and supports shall be of sound timber or steel, masonite, plywood or similar material of sufficient strength and be adequately tight to prevent leakage of mortar.

Formwork ties shall be used to maintain correct separation of vertical surfaces.

Timber formwork for exposed surfaces shall be dressed. All forming surfaces shall be coated with an approved form release agent before pouring commences. Coating shall be done before any reinforcement is fixed in position.

(b) Fixing of reinforcement

Reinforcement shall be accurately placed and tied at alternate intersections with 1.2mm soft iron wire to form a rigid cage or mat which will maintain its shape and position both before and during placing of concrete. Sufficient supporting devices shall be used to ensure the correct concrete cover as shown on the drawings or as required by the provisions of AS3600, if not shown on the drawings.

(c) Cast-in fixtures

All holding down bolts and other fixtures to be incorporated in the concrete shall be accurately fixed in position before pouring.

(d) Inspection

Before any concrete pour, the reinforcement and fixtures for that pour may be inspected by a Representative of Ausgrid. At the time of inspection, the work shall be in every respect, ready for concrete placing. This requirement includes fixing and tying of all reinforcement and cleaning out of formwork.

(e) Transporting of concrete

Concrete shall be transported to its final location as rapidly as practicable by methods which will prevent segregation or loss of ingredients. Under no circumstances shall concrete which has partially hardened, be used.

The containers used for transporting concrete shall be thoroughly cleaned before use.

Pumping of concrete will be acceptable provided the methods and equipment used are approved by Ausgrid. Pumped concrete shall comply with this Specification in all other respects.

(f) Testing of concrete

Testing of concrete shall comply with the provisions of AS3600 and the constituent parts with AS1012. Test results must be supplied to Ausgrid on request.

Test cylinders and slump tests may be taken on site as required by Ausgrid. The minimum sampling frequency shall be that specified in AS3600.

Plant-control testing will be accepted at the discretion of Ausgrid's Representative, provided that the testing is by characteristic strength and that all relevant provisions of AS3600 are met.

(g) Placing and compaction

All water and debris shall be removed from foundations and forms and any flow of water shall be diverted before any concrete is placed.

Concrete shall be thoroughly compacted using mechanical vibration. Manual compaction shall be permitted only when approved by Ausgrid. Over compaction shall be avoided. Concrete shall be thoroughly worked around reinforcement and embedded fixtures and into the corners of the formwork.

To minimise flotation or buoyancy forces on the conduits, the concrete shall have a low slump value (typically 80 – 100mm) and be placed from a minimum height, not exceeding 1.8 metres.

(h) Construction joints

Before fresh concrete is placed against hardened concrete at construction joints, the joint surface of the hardened concrete shall be cleaned by removing all loose and soft material and laitance.

The surface shall be well roughened, thoroughly wetted and covered with a coating of 1:2 sand/cement mortar, against which the fresh concrete is to be placed before the mortar has attained its initial set.

(i) Curing

All concrete work shall be fully protected and kept moist for at least seven (7) days after pouring. After initial set has occurred, all exposed surfaces shall be continuously protected against drying by covering with reinforced building paper or an approved alternative.

(j) Construction loading and stripping time

Formwork and propping shall not be removed earlier than seven (7) days after pouring. During such period, no construction loading of any type or duration shall be permitted without the specific approval of Ausgrid. This requirement prohibits the transportation of loads across concrete surfaces and stacking of materials thereon, prior to stripping of formwork and propping.

Formwork shall be removed in such a way as not to shock or jar the concrete.

(k) Concrete finishing

Unrendered off form surfaces shall comply with the tolerances and surface finish requirements described in Class 3 Formwork of AS3610. Surfaces to be rendered shall comply with Class 4 Formwork of AS3610.

Unformed surfaces shall be finished by steel trowel or equivalent. The top surface of concrete encased conduit banks need not be trowelled.

10. INSTALLATION OF CONDUITS

10.1 General conduit requirements

Where required, the number of conduits and spare conduits shall be specified on the Certified Design/Design Plan, and HV Connection diagram (HV Connection diagram applies only to High Voltage designs). Conduits shall be of the approved type and shall be installed in accordance with the requirements of the Certified Design/Design Plan, and this Network Standard.

Obstructions and other site constraints may make alterations to the Certified Design/Design Plan necessary during installation. Any proposed departures from the Certified Design/Design Plan shall first be submitted to Ausgrid for assessment prior to starting the proposed works.

10.2 Approved conduits

Ausgrid has approved a rationalised range of Unplasticised Poly Vinyl Chloride (UPVC) orange conduits for underground cabling as a minimum standard. The stockcode numbers for these conduits are listed in Annexure G. The application of the various sizes is as follows:

Table 1: Approved conduit size and application

Conduit Size	Application
40mm	Low voltage services
50mm	Low voltage services and street lighting.
63mm	Optical fibre pilot cables
80mm	Low voltage services (refer to NS224)
100mm	Low voltage services supplied from low voltage pits.
125mm	Distribution cables (high voltage including 11kV, low voltage, some street lighting and services). Low voltage cables where high voltage cables have been direct buried
150mm	11kV 500mm ² three core cables where 125mm conduits are not considered adequate, e.g. complex cable routes with multiple bends. Sub-transmission cables, and at other locations as required by Ausgrid

The requirements for the various installation conditions are provided in Table 2. These requirements constitute a minimum standard. The use of heavier class conduits of the same nominal diameter as specified below will be at the cost of the Accredited Service Provider/Contractor and subject to the written approval of Ausgrid. Heavier duty polyethylene conduits are normally required for trenchless installation. Details are to be agreed with the trenchless contractor.

Heavier class conduits can be considered for roadways etc where the ASP has elected to use heavier compaction exceeding the minimum requirements of this Network Standard. In all cases, heavier class conduits and bends shall comply with Clause 14.7 for Testing of Conduits including the use of an approved solid mandrel. Under no circumstances shall a heavier class conduit be joined to a continuous installed length of light duty conduit as this may create issues with the testing of conduits using an approved mandrel i.e. the diameter of the standard mandrel used for the light duty conduit will be too large for the heavier class conduit.

Table 2: Conduit specification

Installation Type	Minimum Conduit Requirements
Complex cable routes with multiple bends when 500mm ² three core cables are used and at other locations approved by Ausgrid.	150mm Light Duty (LD) UPVC (orange) conduit to AS/NZS 2053.2
Concrete encased and sand/cement encased conduits, regardless of location (e.g. CBD conduits, major roadway crossings).	125mm Light Duty (LD) UPVC (orange) conduit to AS/NZS 2053.2
All sand/cement/TSB grouted bore holes	180mm HDPE pipes to AS/NZS 4130. 125mm ID HDPE pipe is used where space constraints do not allow installation of larger pipes.
All State Roadway crossings. All CBD roadway and laneway crossings. All commercial/industrial driveway crossings.	125mm Light Duty (LD) UPVC (orange) conduit to AS/NZS 2053.2
All local and regional roadway crossings, (e.g. URD subdivisions), for high voltage, low voltage and service cables. All light traffic driveway crossings	125mm Light Duty (LD) UPVC (orange) conduit to AS/NZS 2053.2
Conduits in footways and non-roadway easements for high voltage and low voltage network cables	125mm Light Duty (LD) UPVC (orange) conduit to AS/NZS 2053.2
Conduits for low voltage services supplied from low voltage pits	100mm Light Duty (LD) UPVC (orange) conduit to AS/NZS 2053.2
Optical fibre pilot cables	63mm Heavy Duty (HD) UPVC (orange) conduit to AS/NZS 2053.2
Conduits for low voltage domestic services and street lighting cables in footpaths or non-roadway easements	50mm Heavy Duty (HD) UPVC (orange) conduit to AS/NZS 2053.2
Conduits in substation chambers and for high voltage and low voltage cables to and from substation chambers	Sizes, types and quantities are as specified in Network Standard NS113, as amended

Note: Profile wall smooth conduit type conduits shall not be used.

Ausgrid does not presently have a standard range of approved polyethylene pipes for use in trenchless technology (bores). The PE pipes to be used in bores shall generally comply with the requirements of AS4130, with the internal diameter determined in accordance with NS159 Installation of Cables and Conduits using Trenchless Techniques, and wall thickness determined in accordance with the requirements of the bore design (grouting pressure and temperatures).

10.3 Storage of conduits

Orange PVC pipe or conduit does not contain any temporary UV stabilisers. If it is exposed to UV over time, it will whiten on the surface and although it will not lose tensile strength it will become brittle and can become subject to damage from impact loads. Protection from prolonged exposure to direct sunlight can be achieved by under-cover storage, or by covering pipe stacks with an appropriate material such as Hessian. Heat entrapment should be avoided and ventilation provided. Black plastic sheeting should not be used.

10.4 Coupling of conduits

Conduits are to be coupled using spigot and socket arrangements. A suitable primer must be used first on both mating surfaces. PVC solvent cement shall then be applied to bond the primed surfaces.

All joints must be properly made to eliminate the entry of water and foreign matter into the installed conduits.

10.5 Conduit bends

Conduit bends shall be selected giving consideration to the 'during installation' minimum internal cable bending radius as detailed in Tables 7, 8 & 9 of Section 13. Excessive bending of conduits to avoid using conduit bends is not acceptable. Where obstructions require conduits to be diverted, only gradual large radius bends (minimum 2.3 metres) shall be used so as not to limit the size of cables that can be pulled through. Approved bends are listed in the Annexure G.

10.6 Installation of telecommunication conduits

Ausgrid utilises optical fibre cables to carry critical high voltage Tele-protection signals for HV in line with our legal requirements and in accordance with the National Electricity Rules (NER's).

Tele-control, building security, broadband wireless and other telecommunications services are also transmitted through the optical fibre network.

The aim of the Secondary Systems team is to increase the quality and reach of the fibre network through a process of new build and route replacement.

All planned high voltage underground conduit routes should be reviewed by the telecommunications team prior to construction in order to facilitate the objective of a more secure fibre network.

The inclusion of an orange 63mm outer diameter (OD) high density conduit to be run nested with the underground conduits, and protected by HV feeders are only installed where a route potentially forms part of a secure path between major substations.

Note: Low voltage underground installations are excluded from the requirement to install protection fibre conduits.

Where protection fibre conduits are required to be run with the feeder installation, the following Network Standards and drawings shall apply:

- NS203 Telecommunications Network: Master Policy Document.
- NS204 Communications Pits - Specification and Installation Guidelines.
- NS205 Telecommunications: Route Markers.
- NS234 Telecommunications Underground Physical Plant Installation.
- NS235 Telecommunications Underground to Overhead (UGOH) Transition.
- Standards drawing 212393 - Telecommunications Conduit Installations.
- Standards drawing 212386 - Telecommunications UGOH.

It is a mandatory requirement for the inclusion of protection fibre conduits to be installed alongside all new high voltage conduit rail crossings.

Each end of the crossing must be brought outside of rail owned land, capped, sealed and marked with frequency based marker devices as per NS205.

Should the conduit route extend beyond the rail corridor, the termination point should be confirmed through a discussion with the telecommunications team.

For further information, refer to the Manager - Secondary Systems or for contestable works, the Ausgrid officer facilitating the contestable project.

10.7 Sealing of conduits

Refer to NS171, Fire Stopping in Substations for details on Ausgrid's specification and requirements for the installation of fire stopping materials in openings in substation walls, floors and ceilings.

Conduits which are direct buried shall be sealed against the ingress of water and any foreign material which may hinder the removal and/or pulling through of cables. For conduits that form part of a pit and duct system and the pits are located in a tidal area or below the water table, the conduits need to be sealed against the ingress of water. Apart from being susceptible to blockage, unsealed conduits may cause flooding of cable pits and basement type substations and switchrooms.

Unused conduits shall be sealed using the appropriately sized conduit end cap or plug.

Used conduits (i.e. conduits with cables in them) shall be sealed using approved conduit sealing foam/putty.

10.8 Laying of conduits

The roadway conduits at street intersections and other locations should be laid as nearly perpendicular to the street as practicable, terminating at the road-side edge of Ausgrid's cable allocation. Refer to Annexure D for the cable allocation that applies in the relevant area. Minor deviations to align with offset lot boundaries on opposite sides of the road are permitted.

All conduits shall be installed so that they are true to line. The ends of conduits shall be smooth and cleanly cut, with sharp edges removed. Where conduits enter pits, bell mouths shall be installed flush with the inside of the wall.

Once installed, the manufacturer's markings on the conduits must be visible for inspection.

10.9 Banks of conduits

In busy shopping centres, pedestrian malls and the Central Business District of Sydney ('the CBD'), conduits are generally installed in multiple rows linking vaults and pits. These are usually referred to as banks of conduits. Conduit requirements and layouts are usually specified on the Certified design/ Design plan.

Banks of conduits shall be built so that their cross section is rectangular. The exit points at each end of the conduits bank shall correspond exactly without any cross-overs along the conduit lengths.

Conduit banks containing six or more power cable conduits must be installed in thermally stable bedding (TSB) in accordance with Section 11. Conduit bedding material shall be specified on the Certified design/ Design plan.

Conduit banks containing six or more power cable conduits which are short in length (e.g. for local road crossings) may not need to be installed in TSB provided the cables at both ends of the conduit bank are direct laid. In each case, the deletion of TSB shall require a rating assessment completed by the Designer in accordance with NS272, and the rating assessment shall be submitted to Ausgrid for review and approval.

The requirements above apply also to suburban and other areas where the design calls for conduit banks containing six or more power cable conduits. For details regarding the installation of banks of conduits on Private Property, see Clause 4.8.

10.10 Standard conduit and cable spacings

The horizontal and vertical separation between conduits, and between the outer conduits and the bottom and sides of the trench, shall be 50mm for 125mm conduit, and 70mm for 150mm and 200mm conduits. The top layer of conduits shall be covered with 100mm bedding unless otherwise required by this Network Standard.

10.11 Standard depth of cover

The depth of a trench for a conduit will depend on obstructions, the number of conduits to be installed and their orientation with respect to one another. Banks of conduits shall be installed to have a final cover in accordance with the requirements detailed in Table 3.

Table 3: Standard cover and bedding requirements for conduits

Location (Refer Note 1)	Standard Cover (mm)	Minimum Bedding Material
The carriageway of Classified State Roads – Low Voltage and High Voltage Conduits (Note: excluding footways)	1000	Concrete or TSB to achieve 3 to 5MPa See Figure 3
	1200	20:1 sand/cement dry mix See Figure 4
The carriageway of Classified Regional & Unclassified Roads and heavy commercial / industrial car parks – Low Voltage and High Voltage Conduits (Note: excluding City of Sydney Roadway or Laneway)	750	Standard bedding material as per Clause 10.16.1 See Figure 1
City of Sydney Roadway or Laneway.	750	20:1 sand/cement dry mix or TSB See Figure 1 (for sand/cement) or Figure 2 (for TSB)
Footways and driveways of Classified and Unclassified Roads, light commercial / residential car parks - High Voltage Conduits	600	Standard bedding material as per Clause 10.16.1 See Figure 5
Footways and driveways of Classified and Unclassified Roads, light commercial / residential car parks – Low Voltage Conduits	500	Standard bedding material as per Clause 10.16.1 See Figure 6

Note 1: Refer to the following RMS website link for the Schedule of Classified Roads and Unclassified Regional Roads. Local Roads are unclassified roads and therefore are not included in the Schedule.

<https://www.transport.nsw.gov.au/system/files/media/documents/2023/classified-roads-schedule-1.pdf>

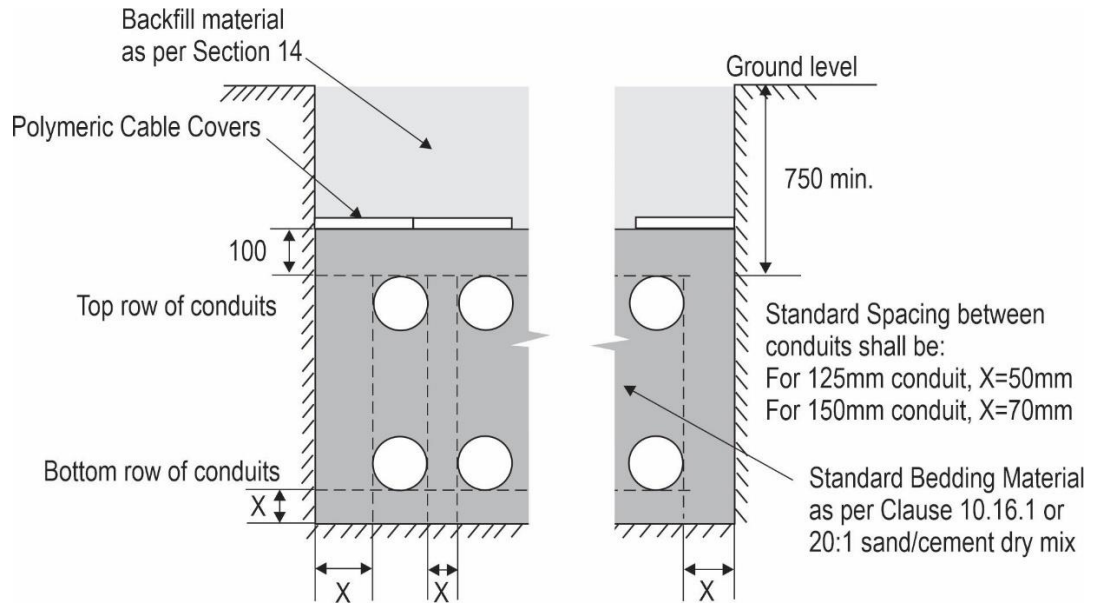

Figure 1: Standard Cover 750mm

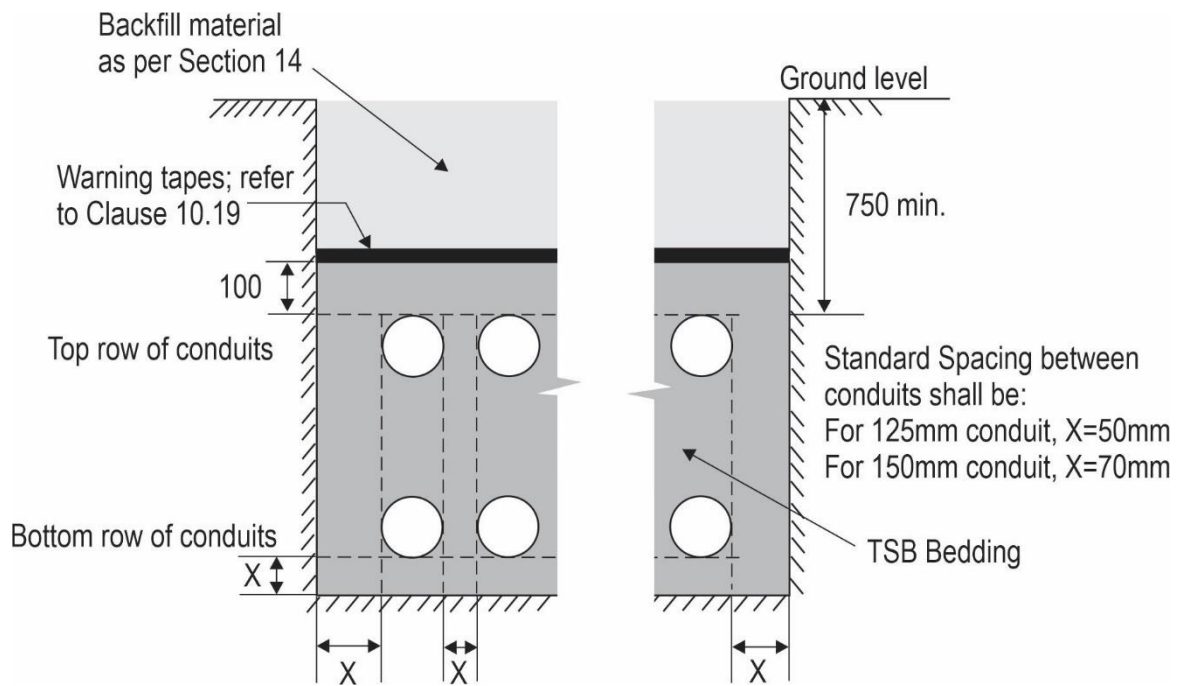

Figure 2: Standard Cover 750mm (for TSB only)

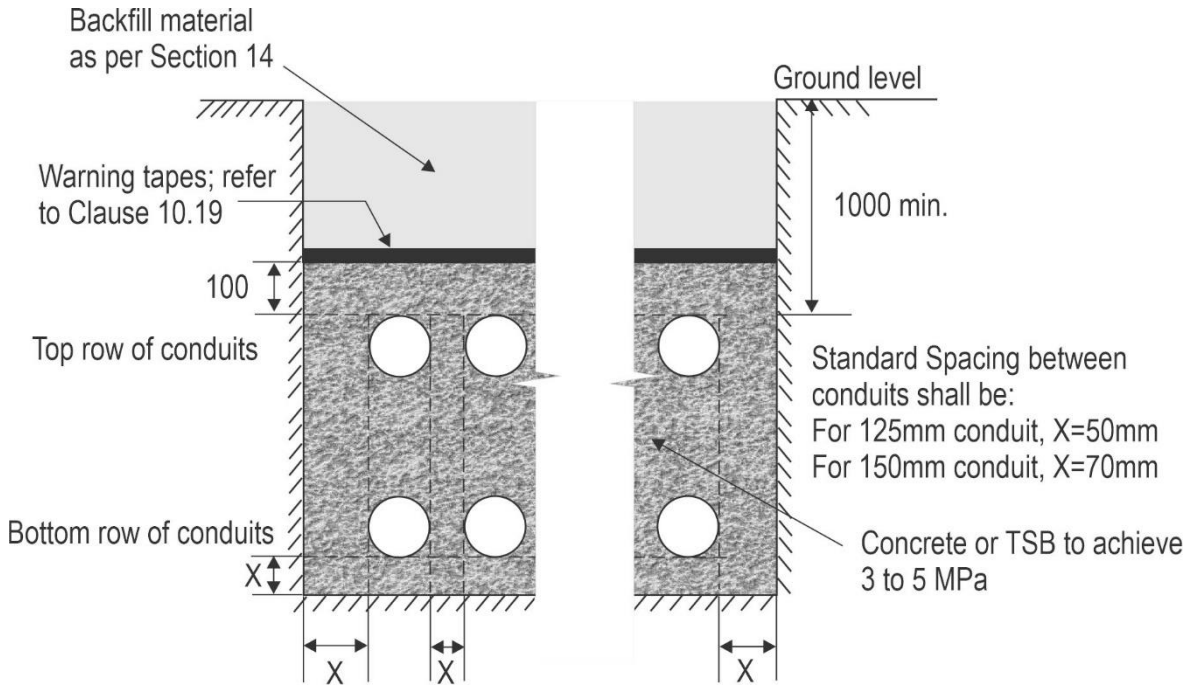

Figure 3: Standard Cover 1000mm

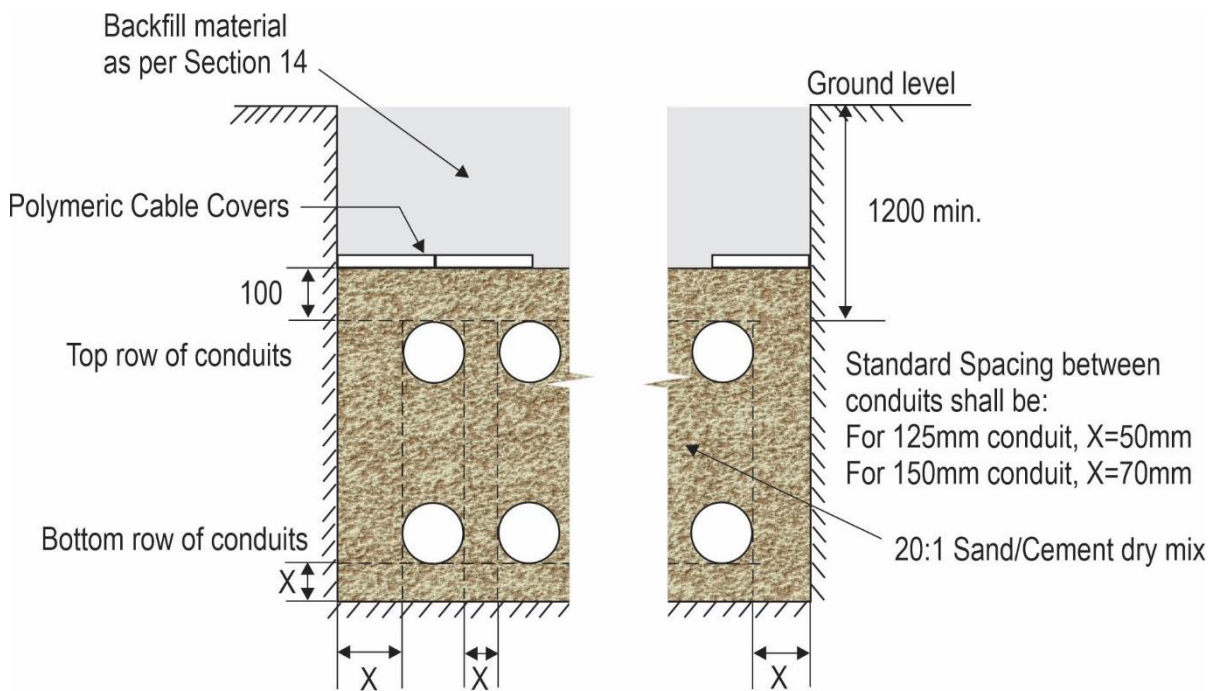

Figure 4: Standard Cover 1200mm

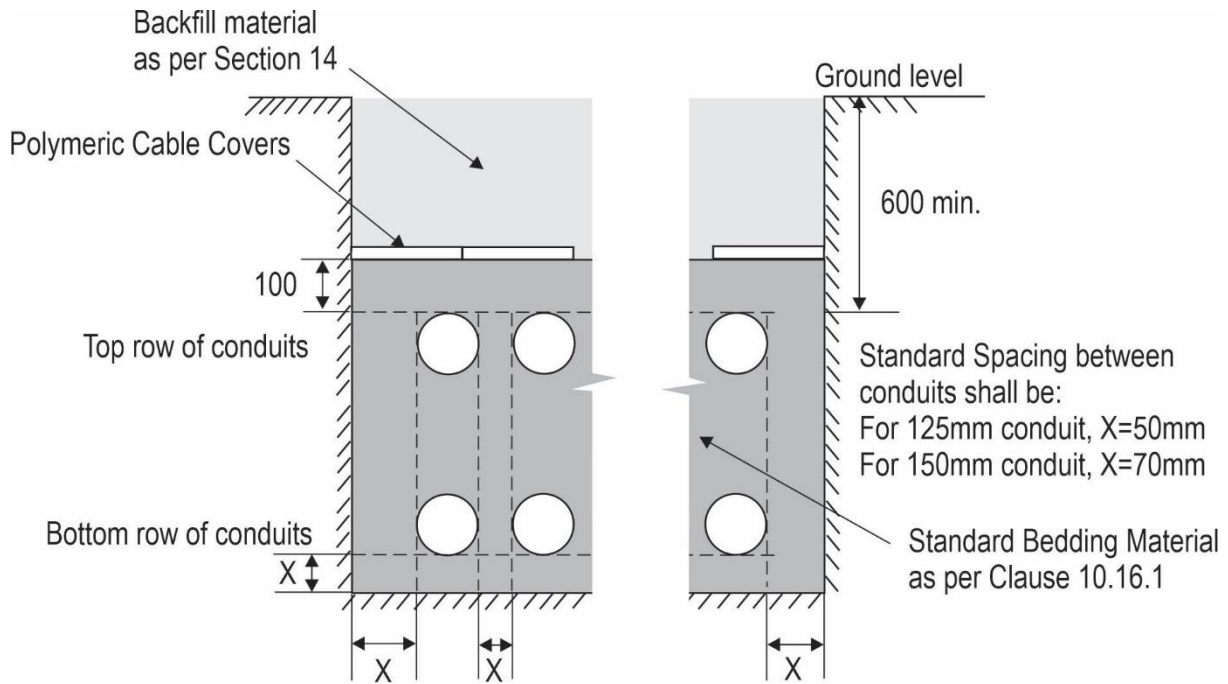

Figure 5: Standard Cover 600mm HV

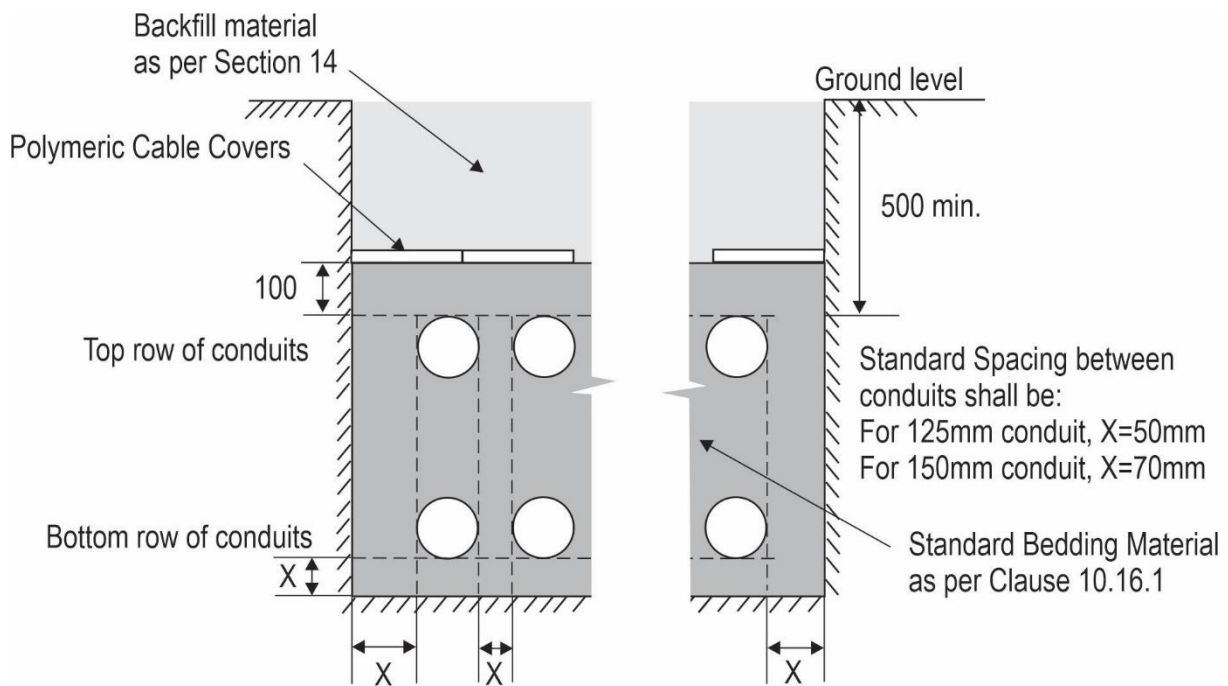

Figure 6: Standard Cover 500mm LV

If the standard depth of cover requirements cannot be met, reduced cover in accordance with the requirements of Clause 10.12 may be allowed by Ausgrid if prior approval is sought.

10.12 Reduced depth of cover

Where it is absolutely necessary to reduce cover over conduits or cables in order to overcome unavoidable site obstructions, the requirements below shall be followed, but only after consultation with an agreement by the group responsible for design and ratings within Ausgrid. It should be noted that this concession DOES NOT provide a blanket approval for reducing the depth of cover. Note also that the cover/protection requirements below generally preclude directional drilling being utilised at reduced cover.

- (a) Cables must be laid in conduits.
- (b) The reduced depth shall be limited to a maximum of 5 metres of continuous trench length. The total length of trenching subject to reduced depth shall not exceed 5% of the total length of trenching involved in any one project or part thereof, unless specifically approved by Ausgrid's Representative.

Where a roadway crossing involves obstructions which necessitate invoking this clause and it can be demonstrated that it would be more practical to do the full roadway crossing at the same reduced depth, Ausgrid will consider exempting the roadway crossing from the 5% rule.

- (c) The transition between standard depth and reduced depth shall be gradual and shall not exceed the minimum bending radius of the cables expected to be accommodated within the conduits. For the purpose of determining the minimum bending radius of spare conduits, and in the absence of any other information, it shall be assumed that 125mm and 150mm conduits will respectively accommodate three core polymeric cables up to 400mm² and 500mm² in cross sectional areas. Refer to Clause 10.5 for further information.
- (d) Trench dimensions, bedding, backfill and protection requirements shall be as specified in Table 4 below.
- (e) Where it is impractical to comply with reduced cover requirements in special concrete encased cable installations e.g. bridge culverts, underneath suspended slabs, within buildings (including cable risers, walls and beams), a clearly visible permanent surface marking at 3 metre intervals along the cable route shall be centrally affixed to all surfaces (where attachments may be made or holes drilled) of the concrete encasement to warn of the presence of these cables. An example of a suitable marking is a 150mm x 65mm rectangular stainless steel warning plate with the words 'DANGER, ELECTRICAL CABLE REDUCED COVER'; secured to surface by stainless steel mushroom head spikes. See Figure 7. Cable ratings outcome shall be maintained.

An example of a larger steel plate is similar to the above marking with 250mm x 180mm dimensions.



Figure 7: Surface marking

Table 4: Reduced cover and backfill requirements for conduits

Location	Reduced Cover (mm)	Bedding / Backfill / Protection Requirements
LV and/or HV conduits in the carriageway of Classified State Roads (Note: excluding footways)	Less than 1 metre and greater than 750mm	Shall be negotiated with the RMS on a case-by-case basis. In addition, polymeric cable covers are to be used (refer to note 2)
	Less than 750mm and greater than 500mm	Shall be negotiated with the RMS on a case-by-case basis. In addition, steel plates and polymeric cable covers are to be used (refer to note 2)
LV and/or HV conduits in City of Sydney Roadway or Laneway.	500*	20:1 sand/cement dry mix or TSB (refer to Figure 8 and Note 1) Steel plates and polymeric cable covers are to be used (refer to Note 2)
LV and/or HV conduits in any other type of roadway and heavy commercial / industrial car parks	500*	Standard bedding material or 20:1 sand/cement dry mix - see Clauses 10.16.1 or 10.15.1 (refer to Figure 8) Steel plates and polymeric cable covers are to be used (refer to Note 2)
HV conduits in footway	450	Standard bedding material - see Clause 10.16.1 (refer to Figure 9) Steel plates and polymeric cable covers are to be used (refer to Note 2)
LV conduits in footway	300	Standard bedding material - see Clause 10.16.1 (refer to Figure 10) Steel plates and polymeric cable covers are to be used (NB. steel plates are considered equivalent to a concrete slab as per AS 3000) (refer to Note 2)
LV and/or HV conduits in other public access areas, e.g. light commercial / residential car parks, recreation areas.	450	Standard bedding material - see Clause 10.16.1 (refer to Figure 9) Steel plates and polymeric cable covers are to be used (refer to Note 2)

* In accordance with RMS Specification M209.

Notes:

1. For TSB mix refer to Clause 11.2.
2. Polymeric cable covers shall be laid across the full width of the trench. Refer to Clause 10.18 for installation parameters.

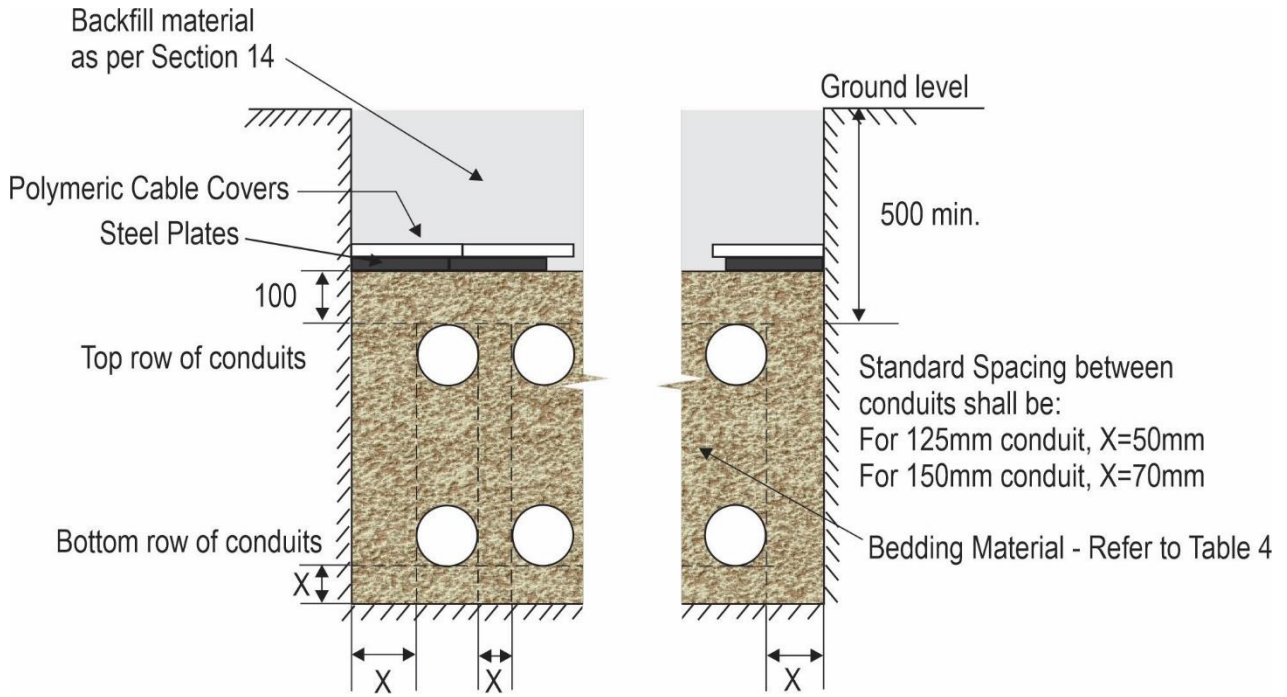

Figure 8: LV and/or HV Conduits in Roadways

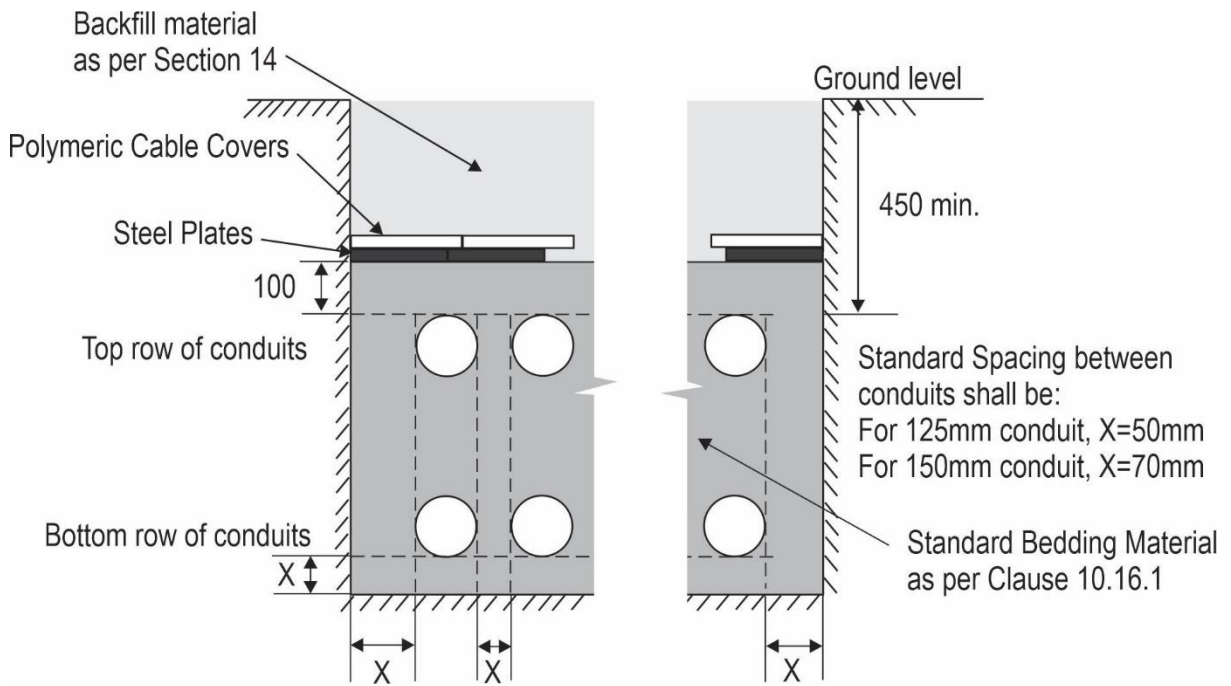

Figure 9: HV Conduits in Footway

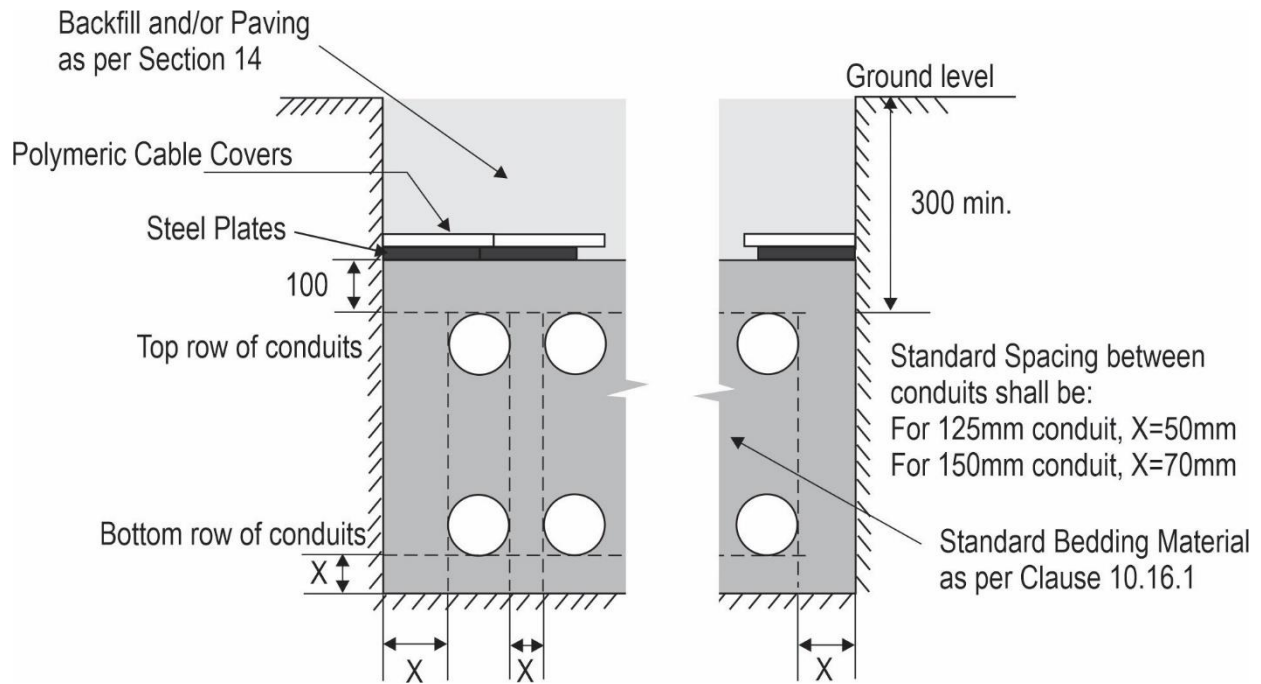

Figure 10: LV Conduits in Footway

10.13 Bedding types

Conduit bedding material shall be specified on the Certified design/ Design plan. The type of bedding material used for banks of conduits (including single conduit installations) shall be in accordance with Table 3 or Table 4.

Additionally, when conduits are installed either below or beside or above other cables or conduits, the conduits shall be encased in the same bedding material as the adjacent cables or conduits unless otherwise directed in the Design Information.

Conduit bedding material shall comprise of one of the following;

- Concrete
- TSB to achieve 1 to 2 MPa compressive strength in 28 days (refer to Table 6)
- TSB to achieve 3 to 5 MPa compressive strength in 28 days (refer to Table 6)
- 20:1 sand/cement dry mix
- Standard bedding material.

Any variations to bedding materials will require Ausgrid's approval before implementation.

10.14 Concrete encased conduits

10.14.1 General

Refer to Section 9 for information on concrete construction work in general. All concrete used for conduit encasement shall have a characteristic strength as stated in Table 3 or 4, at twenty eight (28) days. Note that in order to maintain cable ratings, concrete used for encasing conduits must not adversely affect the transfer of heat to the soil and atmosphere. In particular, the following requirements must be adopted in designing the concrete mix:

- The specific concrete specifications required for the concrete encasement of the HV conduit line is to be indicated on the drawings. Ausgrid's requirements, including those indicated below, shall be referenced.
- Admixtures in the concrete mix shall be subject to the approval of Ausgrid following the submission of a product specific data sheet. The use of accelerators to speed concrete curing or admixtures that entrain air will not be approved.
- The total fly ash in the concrete mix (by weight) shall not exceed 5% unless separately approved by Ausgrid. Fly ash reduces the thermal performance of the installed conduit bank.
- Lightweight aggregate and air entraining agents shall not be used.
- Where reinforcement is required, detailing shall be arranged to reduce the potential for induced currents. Transverse reinforcement around the conduit bank shall not form a closed loop at any location.
- ASPs or contractors wishing to vary concrete mix from approved requirements shall provide documentation demonstrating that their proposal achieves the specified thermal resistivity (TR) value without increasing the in-situ concrete curing temperature such that conduits are likely to be damaged.
- The standard thickness of the concrete encasement on the top, bottom and each side of the conduits in a conduit bank shall be as specified in Table 5 below. Where the depth of cover over the conduits has to be reduced, the requirements for encasement shall be as specified in Clause 10.12.

Table 5: Concrete encasement dimensions

Conduit Size	Minimum Encasement Thickness (mm)		
	Top	Bottom	Sides
125mm	100	50	50
150mm	100	70	70
200mm	100	70	70

Encased conduits shall be installed with suitable spacers between the conduits prior to placing the encasement material.

Where construction joints in the encasing material occur, each joint shall be provided with at least four 16mm diameter steel dowels, extending into the encasement material for 450mm on either side. Two additional dowels shall be provided for every additional row of four conduits above four installed.

Conduits should be secured to avoid flotation during the pouring of concrete. This may be achieved by tying the conduits with rope at three metre intervals and anchoring the conduits using timber stakes driven into the cable trench, or by other approved methods.

Concrete encasement should be designed to ensure the heat of hydration does not result in overheating and deformation of the conduits. Ausgrid specifies that conduits shall not be damaged by operation at 80°C.

The conduits shall be fixed in place so that the top concrete cover remains at no less than 100mm. Special attention shall be paid to recording the depth of cover (refer to NS100, Field Recording of Network Assets). The Constructor for the work shall be responsible for ensuring that the concrete cover over the top conduits is uniform, or if this is not possible, that the actual cover is accurately recorded, in accordance with NS100. Depth gauges may be used if required to measure the actual cover at critical locations.

Figure 11 shows the typical layout of a nine-way bank of conduits where 125mm conduits are installed as three layers of three.

Figure 12 shows a nine-way bank of 150mm conduits.

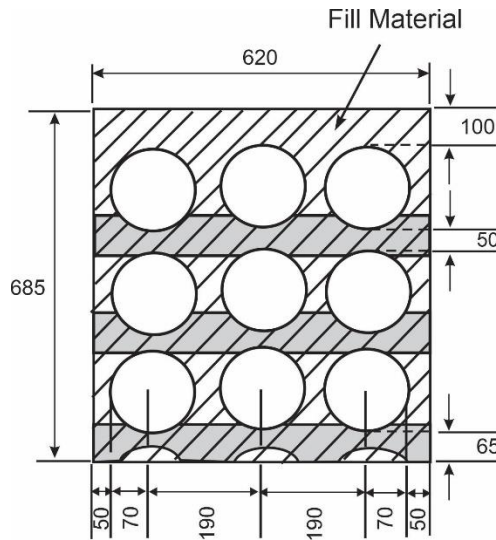

Figure 11: Nine-way bank of 125mm Conduits

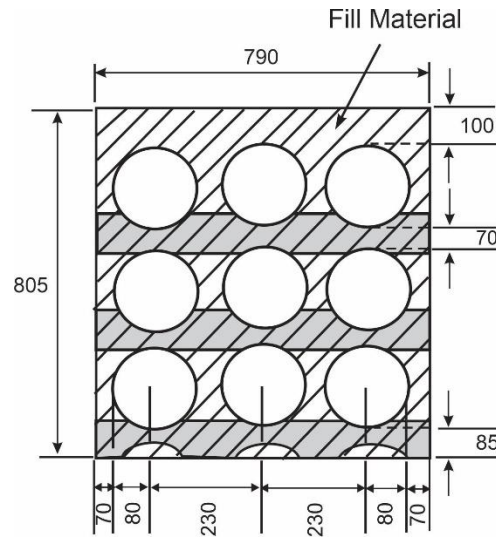

Figure 12: Nine-way bank of 150mm Conduits

10.14.2 Plastic conduit spacers

The Plastic conduit spacers are for TSB slurry mix or concrete slurry material and shall be used for installations to keep conduit separation based on cable rating requirements and to allow TSB slurry mix/concrete slurry to flow as required. The main purpose of the spacers is to keep the conduits in their correct position relative to each other and the surrounding soil, and to prevent them from floating as the trench is backfilled. They must be designed so as not to damage the conduits if they soften due to the heat generated by the TSB slurry mix or concrete as it cures.

Various spacer types are commercially available.

10.15 Sand/cement bedding of banks of conduits

10.15.1 Sand/cement bedding

Sand/cement dry mix used for bedding conduits shall be portioned 20 parts sand to 1 part cement and thoroughly mixed before placement to ensure that concentrations of cement do not occur. Sand/cement dry mix shall be delivered direct from the batching plant and shall not be stockpiled on site.

10.15.2 Construction procedure

Sand/cement bedded conduit banks shall be constructed using the procedure for dry bedding of conduits in Clause 10.17.

10.16 Standard bedding of banks of conduits

10.16.1 Standard bedding material

It is of paramount importance that appropriate bedding material is used for bedding conduits in an open trench. Standard bedding materials shall meet the following requirements unless specifically approved otherwise by Ausgrid:

Standard bedding materials shall be finely divided and stone free where no less than 95% by mass shall pass through a 2.36mm mesh sieve with 100% by mass passing through a 4.75mm mesh sieve. The material shall be free of glass, metal, sharp objects, slag, organic or other harmful substances. Clay that is removed during excavation work is not suitable as a standard bedding material. It must be replaced with a suitable clean bedding material. Standard bedding material must have suitable thermal resistivity to ensure the ductline meets the distribution network rating requirements.

Recycled 'GlassSand™' and other recycled crushed glass products are not approved bedding materials.

10.16.2 Construction procedure

The conduit banks shall be constructed using the procedure for dry bedded banks of conduits in Clause 10.17.

10.17 Procedure for dry bedded banks of conduits

The bedding compaction ratio shall be minimum 3:2.

Dry bedded banks of conduits shall be constructed using the following procedure:

For 125mm conduits:

1. Place a 75mm deep layer of approved bedding material at the bottom of the trench and compact the bedding down to 50mm.
2. Lay the first row of conduits. Maintain a minimum separation of 50mm between conduits, and 50mm between the outer conduits and the sides of the trench.
3. Place bedding material over the first row of conduits to a depth of 285mm and compact the bedding material down to 190mm.
4. Lay any additional rows, then place more bedding material and compact between the rows in the same manner.

5. Place a 150mm layer of bedding material over the top layer of conduits and compact down to 100mm.

For 150mm conduits:

1. Place a 105mm deep layer of bedding material at the bottom of the trench and compact the bedding down to 70mm.
2. Lay the first row of conduits. Maintain a minimum separation of 70mm between conduits, and 70mm between the outer conduits and the sides of the trench.
3. Place bedding material over the first row of conduits to a depth of 345mm and compact the bedding material down to 230mm.
4. Lay any additional rows, then place more bedding material and compact between the rows in the same manner.
5. Place a 150mm layer of bedding material over the top layer of conduits and compact down to 100mm.

Notes: When adding and compacting the bedding material, care shall be taken to avoid dislodging the laid conduits from their required position.

The layer of bedding material over the conduits shall be carefully consolidated using hand rammers only. Under no circumstances shall mechanical rammers be used to consolidate the bedding material.

On steep inclines and other locations where scouring of the bedding material is likely to occur, bulkheads consisting of bags packed with 20:1 sand/cement mix must be installed at regular intervals.

10.18 Protection of conduits

Conduits are considered to be inherently protected from mechanical damage, provided they are installed with a standard depth of cover (refer to Clause 10.11) and are either:

- concrete encased, or
- TSB encased, or
- installed using Trenchless Technology.

These installations do not require cable protection covers unless specifically requested in writing by Ausgrid. Critical or high risk Sydney CBD installations are possible locations where additional cable protection covers may be required. Warning tapes shall be provided in accordance with Clause 10.19.

All other conduit installations, including those installed with standard or reduced depth of cover with standard bedding material or 20:1 sand/cement dry mix bedding, shall be protected against mechanical damage using Ausgrid approved cable protection covers laid directly above the bedding material.

For reduced cover installations, additional protection against mechanical damage shall also be provided in accordance with Clause 10.12.

Currently approved cable protection covers are of the polymeric type complying with Ausgrid's performance requirements. The standard sizes used and the corresponding stockcode numbers are listed in Annexure G.

Where there is a single conduit in the trench, a single 150mm or 300mm wide strip of polymeric cable cover shall be used. The single cable cover shall completely cover and be centred over that conduit.

Where 2 or more conduits are laid side-by-side, the wider 300mm size of polymeric cable cover shall be used.

If more than one strip of 150mm wide polymeric cable covers is required side by side, 300mm wide strips shall be used.

Polymeric cable cover strips laid side-by-side shall butt up against each other. Polymeric cable cover strips laid end-to-end shall overlap by approximately 20mm.

Cable covers must be immediately secured in position by covering with a 150mm thick (minimum) layer of backfill material.

10.19 Use of warning tape

Warning tape, as listed in Annexure G, shall be used in the following circumstances:

- over concrete encased conduits
- over TSB encased conduits
- where specifically required by Ausgrid.

Where used, the tape shall cover the full width of the trench, or portion thereof containing the conduits. Where two or more strips of warning tape are laid side-by-side, they shall overlap by 20mm. Warning strips shall be immediately secured in place by a 150mm minimum covering of backfill material.

10.20 Inspections by Ausgrid

Ausgrid has the right to inspect all works regarding the installation of its assets. If access to our assets is unavailable, then the constructor must provide Ausgrid access at the constructor's expense.

10.21 Kerb marking

Permanent kerb marking must be provided (except where there is no kerb or gutter) at all roadway conduit crossings and under road borings, using the letter E (for Electricity). The markings shall be done by engraving or other approved means, and shall be positioned on the face of the kerb directly above the installed conduits at both sides of the roadway crossing.

Note: Permanent markings shall not be installed in heritage situations unless approved.

For example, permanent kerb marking may consist of an approved stainless steel 'E' plate anchored onto the kerb as shown in Figure 13. The supplier is Hi-Tech Horizontal Drilling.
<http://www.kerbmarkers.com.au>



Figure 13: Approved kerb marking

10.22 Bridge crossings

Where bridge crossings are required, specific structural designs must be provided. Before any work occurs, the design must be certified, and authorisation must be obtained from the relevant bridge Authority/Owner and from Ausgrid.

The cable and cable/conduit support design shall allow for the expected bridge movements (vertical and longitudinal).

Cable design shall meet the distribution network rating requirements.

For exposed HV and LV cables and conduits, suitable measures shall be used to provide adequate mechanical protection and to restrict public access. These measures shall be subject to review and approval by Ausgrid.

For all bridge crossings, clearly visible permanent surface marking at 3m intervals along the cable route shall be provided, in accordance with Clause 10.12.

All bridge crossings shall have a rating assessment completed by the Designer in accordance with NS272, and the rating assessment shall be submitted to Ausgrid for review and approval.

11. THERMALLY STABLE BEDDING MATERIAL

11.1 General

Ausgrid uses the generic term Thermally Stable Bedding (TSB) in referring to any thermally stable bedding or backfill material which has been designed to achieve specific thermal characteristics.

Where Ausgrid specifies the use of TSB material, the installation shall meet the following requirements, unless specifically approved otherwise by Ausgrid.

Generally, cable design should not require the use of thermal backfill above the cable warning tapes on distribution projects as use of TSB could create an obstruction to other utility services in footpath or road crossing locations.

TSB must be used in accordance with any relevant resource recovery orders and exemptions issued by the NSW Environment Protection Authority (EPA). The coal ash order and exemption 2014 apply to products that contain fly ash.

11.2 Approved materials and mix design

TSB is available in the form of Slurry or Dry mix.

The slurry mix is the default mix. Dry mix shall only be used with the approval of the Ausgrid representative.

The following table outlines the required performance characteristics of the TSB:

Table 6: Performance characteristics of TSB mixes

Site Location	Thermal resistivity (TR) K.m/W (fully dry)	Compressive Strength (MPa) at 28 days	Compressive Strength (MPa) at 120 days
Footways, Unclassified roads & Classified Regional roads	0.9 or less	1 to 2	Less than 3
Classified State roads	0.9 or less	3 to 5	Less than 7

Any design requiring the use of TSB shall comply with the performance requirements of the above table. The Designer shall clearly specify the site location of the TSB mix in the design in the following way:

- 'TSB - Footways, Unclassified roads & Classified Regional roads', or
- 'TSB - Classified State roads'.

For the Schedule of Unclassified Roads, Classified Regional Roads and Classified State Roads, refer to the following RMS website link:

<https://www.transport.nsw.gov.au/system/files/media/documents/2023/classified-roads-schedule-1.pdf>

The Constructor shall ensure that the selected TSB mix complies with the design.

Key parameters of TSB – unless otherwise approved by Ausgrid are:

- Flyash Content - 5% max (by weight) unless approved by Ausgrid
- Course Aggregate - 10mm max size crushed gravel.
- Admixtures for Pumping etc - subject to Ausgrid approval (product specific data sheet required).
- Lightweight Aggregate - not allowed
- Air Entrainers - not allowed
- Early Strength Accelerators - not allowed.

Key components of TSB are:

- Cement
- Flyash
- Crushed gravel
- Coarse sand
- Water.

Ausgrid's Approved Material List (AML) provides a list of suppliers of TSB mixes and their product codes.

TSB mixes from other suppliers not listed in the AML can also be submitted to the Ausgrid Representative for consideration using the NS181 approval process. In this case, the Constructor shall provide the Ausgrid Representative a TR test report, Compressive Strength test report and mix design / recipe for review.

The Constructor shall provide a copy of the TSB delivery docket to the Ausgrid Representative for every batch of TSB mix supplied and shall demonstrate compliance with the AML for the approved TSB mix and site location specified in the design. If the TSB mix is not listed on the AML, the Constructor shall demonstrate compliance of this TSB mix to a design approved by Ausgrid for the site location.

Once approved, the TSB mix design shall not be modified without the further approval of Ausgrid. All materials used in the approved mix design shall continue to be sourced from the original locations to ensure consistent strength and TR values. Any change to the source of material supply will require a revised mix design, re-testing of strength and TR values, and the subsequent approval of Ausgrid.

11.3 Default slurry mix

11.3.1 General

Application: All trenches and banks of conduits requiring TSB unless otherwise authorised.

A slump of 110mm average (range 90mm to 130mm) shall be adopted as the standard for most projects. Water may only be added on site to restore the correct slump – never to speed installation.

Where vibration is required, it shall be strictly controlled in accordance with Clause 11.3.2.5 due to the risk of aggregates segregating out and reducing thermal performance.

If a lower slump is required for sloping sites and it is found that the mixture is not fully encapsulating the conduits, properly specified vibration (not more than 3 seconds in any one location of TSB) shall be used to ensure the mix is properly blended. Vibrating must be monitored to ensure it does not damage the conduits and to ensure components do not segregate out.

For typical examples of slurry mix designs that may satisfy the performance requirements, refer to Annexure L.

11.3.2 Installation of thermally stable slurry mixes

11.3.2.1 Trench preparation

The trench should be free of all debris and standing water before the bedding mix is poured. A small amount of water in the trench is acceptable.

11.3.2.2 Typical installation methodologies

The conduit installation methodology and the required trench dimensions shall be in accordance with Clause 10.14 for concrete encased conduits.

11.3.2.3 Flotation

Since thermally stable bedding mixes are a hydraulic fill, conduits may tend to float, and therefore they must be secured to the bottom of the trench. The TSB shall be placed from a minimum height that does not exceed 1.8 metres.

11.3.2.4 Placing of TSB

TSB shall be supplied and transported to site in agitator trucks. The mix should be installed by controlled pouring around the conduits or cables in accessible trench locations. Where the use of mechanical compaction/ vibration is required, it shall be strictly controlled in accordance with Clause 11.3.2.5.

11.3.2.5 Compaction of TSB

The normal TSB mix design, slump and placement techniques should be such that there is no need for additional mechanical compaction/vibration for most installations.

Where further compaction of the TSB is deemed to be required, the preferred method is by the use of immersion vibrators. Vibration of TSB shall only be undertaken by trained and experienced operators using equipment that is suitably sized for the installation. The use of vibrators shall be constantly monitored to ensure proper technique, suitable immersion times and complete coverage of the TSB installation.

In this regard, it should be noted that compaction is a two stage process that involves:

- (a) Initial Consolidation – aggregate particles are set in motion and slump to fill the formed space giving a level top surface.
- (b) Entrapped Air is expelled – air bubbles rise to the surface over a period of time after the surface has levelled.

Both stages need to be effectively completed to produce a dense, compacted material with minimal entrapped air voids.

Poorly monitored or excessive vibration may cause segregation of the mix aggregates and thereby reduce the thermal performance of the TSB.

11.3.2.6 Air voids

TSB slurry mixes shall be designed to minimise entrapped air voids, and reduce the need for additional mechanical compaction/ vibration where possible.

Work methods must ensure that any gaps and air voids (such as those caused by cracking of the mix or removal of shoring materials) are completely filled with either a sand /cement mix or TSB as required.

11.3.2.7 Bleed water and hardening

As the bedding mix starts to solidify, it will bleed excess water to the surface. In poorly draining native soils, provision shall be made to allow this bleed water to either drain away or be pumped away prior to the placement of any backfill material.

The bedding mix will set within 6-8 hours of it being placed. The mix shall be left for a minimum of 8 hours to cure without any disturbance and before backfilling of the trench commences.

11.3.2.8 Formwork removal

If the trenches are shored or bulkheads are used on sloping ground, the shoring should be removed during the mix pour or within one hour after the mix is poured, that is, while the mix is still in a semi fluid state. However, the mix should not to be allowed to develop cracks as it flows into the space created by removal of the shoring.

If cracks or voids are found, these shall be filled in by pouring additional TSB material into them. Limited vibration, in accordance with Clause 11.3.2.5, may be used to ensure the TSB effectively fills the void left by the shoring.

11.4 Dry mix

Application: Difficult site locations where default slurry mix is not practical (steep slopes, road crossings requiring immediate backfill). This mix must not be used unless written approval is obtained from Ausgrid.

This dry mix gives a fully dry nominal thermal resistivity value of 0.9K.m/W when compacted to 98% Standard Proctor. Refer to Clause 10.17 for suitable installation methods applicable to dry bedded banks of conduits.

Special care must be observed with thorough mixing of the ingredients, installed moisture content, and proper compaction measures.

For a typical example of a dry mix design that may satisfy the performance requirements, refer to Annexure L.

11.5 Alternative TSB materials

On any project, alternative mixes may be used, provided test results demonstrating thermal and mechanical performance are submitted to the Ausgrid representative for approval prior to use.

Once approved, the alternative mixes may be used on other projects, provided there are no unapproved changes to the mix design, and the TSB characteristics are compatible with the requirements of the other projects.

Alternative mix designs shall not be modified once approved and all materials shall continue to be sourced from the original locations as required by Clause 11.2.

11.6 Minimum coverage of thermally stable bedding

The minimum coverage of TSB around the conduits shall be 50mm on the sides and base, and 100mm above. This cover may need to be increased depending on the detailed cable design, for example installations involving a large number of conduits at zone substation outlets (to ensure they meet the distribution network rating requirements).

TSB shall not be used as backfill material (above the cable warning tapes) for installations in footpaths or road crossings, unless approved in writing by Ausgrid.

11.7 Testing

For effective TSB performance, periodic tests are required to ensure that:

- the specified mix ingredients continue to be used, and “similar” ingredients are not substituted without approval, and
- the TSB mixes achieve their designated function, including thermal and mechanical characteristics.

TSB mixes shall be tested according to the following guidelines:

- prior to delivery of the first batch of a new mix (i.e. from a new batch plant or source of supply), and
- whenever one or more ingredients are to be sourced from a different location or supplier, and
- at least every 50m length of trench or part thereof (see below).

Each test shall consist of assessment against the criteria specified in Clause 11.2. In addition, slump shall be tested prior to every installation of slurries, while compaction testing of dry mixes shall be as specified in Section 16 for testing of backfill materials at specific locations.

Testing Frequency for Trench Installations

An installation using TSB material shall have thermal resistivity (TR) and 28 day compressive strength sampling and testing performed as follows:

- Trenches <50m long - one sample per trench location
- Trenches >50m long - one sample per 50m length of trench or part thereof, with sample locations being equally spaced along the trench length.

The location/s of the sampling must be accurately recorded and provided with the TSB test results to Ausgrid no later than six (6) weeks after the sampling, who will submit them to:

- gis@ausgrid.com.au for incorporation into Ausgrid's Geographic Information System (GIS), and
- [TR and TSB results@ausgrid.com.au](mailto:TR_and_TSB_results@ausgrid.com.au) for ongoing review of the TSB performance characteristics.

For thermal resistivity testing requirements and procedures refer to Annexure K.

12. INSTALLATION OF PILLARS AND RAG-BOLT ASSEMBLIES FOR STEEL LIGHTING POLES

12.1 Installation of pillar bases

The pillar base is installed in the footpath, square to the kerb, with the centre of the top opening 400mm in front of the street alignment, and normally in a direct line with the extension of the Lot Boundary line. For link pillars (i.e. single and double) the short edge of the pillar base shall be installed parallel to the building line and for all other pillars (i.e. solid pillars, underground SLCP pillars) the long side of the pillar base shall be installed parallel to the building line.

Refer to NS224 Low Voltage Suburban Commercial and Industrial Underground Distribution Utilising Pillars, for installation requirements of suburban commercial and industrial pillars

Use sand-filled bags, or other means, to build a stable column in the trench to support the pillar base, enclose the distributor, service cables and service conduit stubs, and cover any high voltage cables.

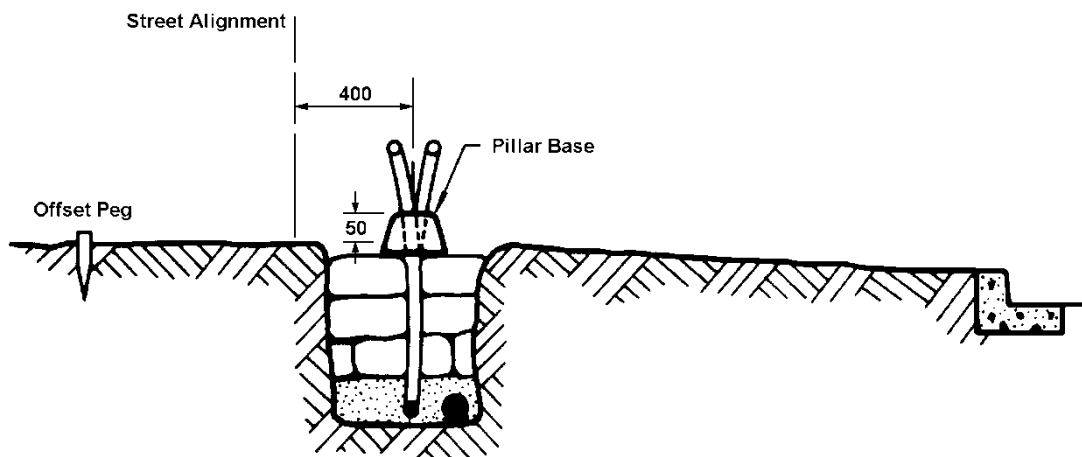

Figure 14: Pillar Base Alignment Details

Position the base so that the top is level and 50mm above the footpath level at street alignment as shown in the above figure. Allow for grass when determining the final footpath level.

Cable terminations shall be installed in accordance with NS127 Low Voltage Joints and Terminations or NS224 Low Voltage Suburban Commercial and Industrial Underground Distribution Utilising Pillars.

Once the distributor and service cables have been installed and terminated, the trench around the base and supporting structure must be backfilled with well-compacted granular soil.

12.2 Installation of rag bolt assemblies for steel lighting poles

Rag-bolt assemblies are used as mounting bases for some steel lighting poles. Rag-bolt assemblies must not be erected before the finished ground level has been ascertained from the local authority.

Unless otherwise specified, the centre line of the rag-bolt assemblies shall be positioned 400mm from the street alignment, as shown in Figure 15.

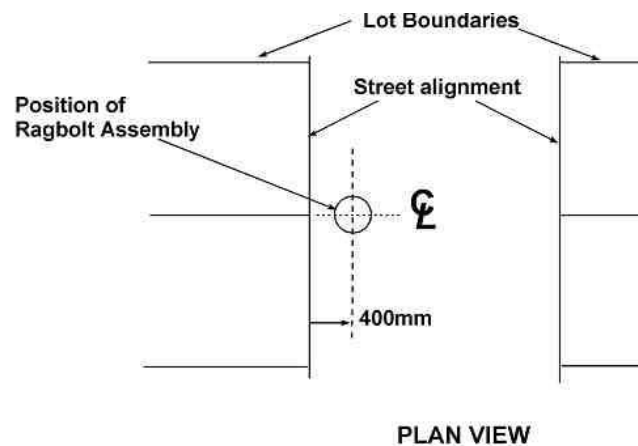

Figure 15: Rag-bolt Alignment Details

Installation of the pile footing, rag-bolt assembly and plinth shall be in accordance with Ausgrid drawing 514087, using plinth steel mould to Ausgrid drawing 514020.

The rag-bolt assembly must be installed in a 600mm diameter hole. Where unstable ground exists or shared trenching is used, a 600mm diameter former tube must be fitted to the hole.

The hole or former tube must be filled with 32MPa concrete. Any gaps around the concrete core must be filled with well compacted granular soil, and any sharp edges must be removed after the concrete has set.

Once in its final position, the rag-bolt assembly must:

- be vertically aligned in both planes
- be square to the kerb
- have its centre line 400mm from the street alignment (unless specified otherwise)
- have the top of the threaded rods 100mm above the top of the plinth steel mould in accordance with Ausgrid drawing 514087.

Once the street lighting cables have been installed and terminated in accordance with NS119 Public Lighting Design and Construction, the trench around the rag-bolt assembly must be backfilled with well compacted granular soil.

13. INSTALLATION OF POWER AND CONTROL CABLES

13.1 General requirements

Refer to NS100, Field Recording of Network Assets – External Annexure C; Cable Codes & Nomenclature.

Cables must be installed in the correct allocation, and with the specified separation from other cables and the sides of the trench. Refer to Clause 10.10 and Annexures B, C and D for further information.

13.1.1 Pilot Cables

13.1.1.1 Sydney CBD

The Sydney CBD 11kV Triplex network uses a "coloured" pilot cable system with:

- Red associated with the A, D, G, K, etc feeder
- White associated with the B, E, H, L, etc feeder
- Blue associated with the C, F, J, M, etc feeder.

Under no circumstances shall alternative coloured pilot cable be installed on the Triplex network. Placing coloured heat shrink tubes over the pilot cable or using labels to indicate the pilot's true colour is also not acceptable on the Triplex network.

The coloured pilot cable shall be installed in the same conduit as its associated Triplex feeder power cable. Any deviation from this requirement shall require prior approval from Ausgrid via NS181 processes. In cable pits, vaults, rooms, tunnels, chases, joint bays and risers, the coloured pilot should be cable tied, cleated or grouped with its associated Triplex feeder power cable.

13.1.1.2 Other than Sydney CBD

The pilot cable shall be coloured black and installed in the same conduit as the feeder cable.

13.1.1.3 Segregation of Pilot Cables

Pilot cables shall be attached to the walls or roof of the cable pits by use of a re-enterable approved fixture:

- Hilti bunched-cable holder: X-ECH-S U37 #386235
- Hilti bunched-cable holder: X-ECH-M U37 #386236

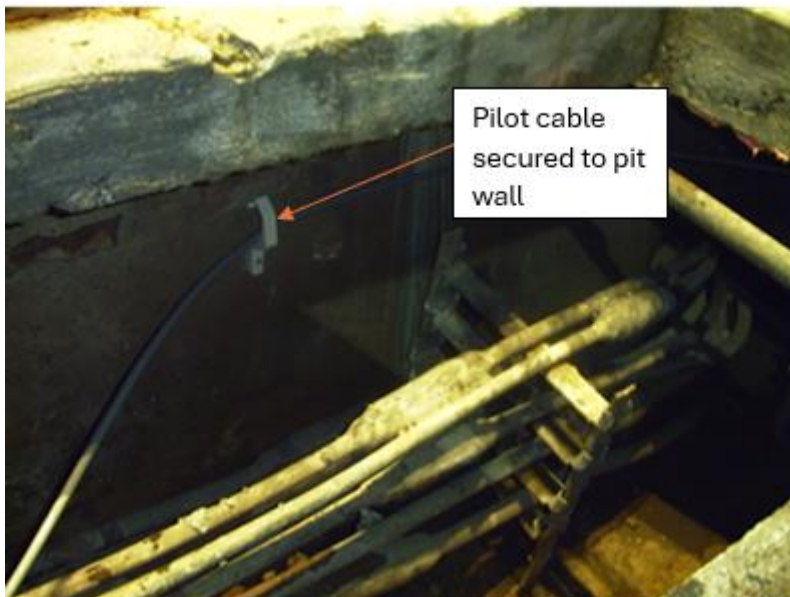

Figure 16: Pilot cable secured to pit wall

The fixture shall be capable of holding more than one pilot cable, and future pilot cables shall use existing fixtures where possible.

13.2 Testing of conduits prior to use

Prior to the commencement of the cable installation, all conduits intended to be used, whether newly laid or pre-existing, shall be thoroughly cleaned and mandrelled in accordance with Clause 14.7.

13.3 Direct buried cables

13.3.1 General

Direct buried cables shall not be installed in carriageways.

Direct buried cables may be buried in sand or 20:1 sand-cement dry mix, depending on site-specific installation requirements. Refer to Clause 10.16.1 for standard bedding material requirements, or to Clause 10.15.1 for sand/cement bedding material requirements.

The bedding material around direct buried cables shall be placed in three or more defined layers using a minimum compaction ratio of 3:2 and shall meet the cable spacing requirements of Clause 13.3.2. Each bedding material layer shall be compacted down to 2/3 of the "loose" volume, shall have a final compacted thickness not exceeding 200mm and shall be arranged so that the final layer provides the required top cover to the direct buried cables. The layer of bedding material over the direct buried cables shall be carefully consolidated using hand rammers only. Under no circumstances shall mechanical rammers be used to consolidate the bedding material.

All direct buried cable installations shall be protected against mechanical damage using Ausgrid approved cable protection covers laid directly above the bedding material.

Concrete or TSB shall not be used as bedding material around direct buried cables.

Coarse aggregates shall not be used in trenches with direct buried cables, due to risk of damage to the cable during compaction.

Cables that are direct buried and surrounded or partially surrounded in a sand/cement mix are known as solid laid cables. When excavating around such cables extreme care must be taken to avoid creating a hazardous condition to personnel, or damage to the cables.

When solid laid cables are encountered, the constructor shall consult with Ausgrid to arrange for all solid laid cables at the work site to be de-energised before work continues. This will eliminate the possibility of hand held tools penetrating the energised cables. Alternatively, a hydro vacuum excavator can be used to expose all solid laid cables without the need for de-energisation, provided the precautions detailed in NS156 are followed.

Where the solid laid cables are de-energised, the constructor shall prepare a work procedure designed to safeguard Ausgrid's assets against any mechanical damage whilst exposing the cables.

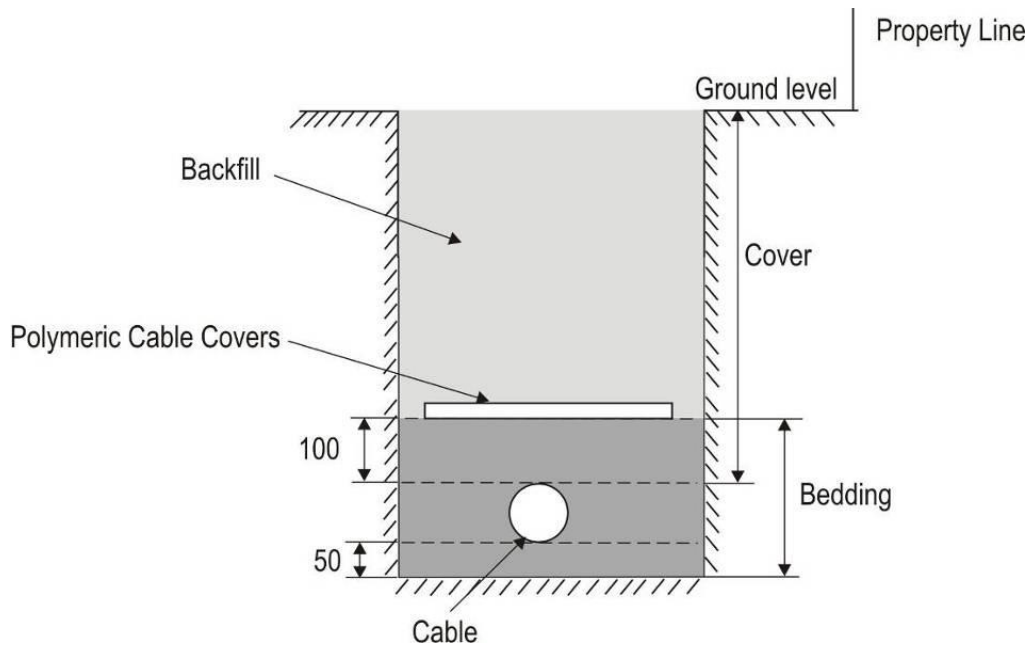

Figure 17 Cable Installation Details (Direct Buried)

13.3.2 Standard cable spacing

Direct buried cables shall have minimum 50mm horizontal and vertical separation between cables and between the outer cables and the bottom and sides of the trench. The top layer of cables shall be covered with 100mm bedding unless otherwise required by the Network Standard. The installation shall meet the distribution network rating requirements.

13.3.3 Standard depth of cover for direct buried cables

Standard depth of cover for direct buried cables is the same as in Clause 10.11. (Note: In this case, the depth of cover is to the top of the cable).

13.4 Sealing of cables

13.4.1 General

All power and control cables shall be protected against moisture ingress, including while being laid, regardless of site and/or weather conditions.

Cable ends which are not intended to be worked on immediately after laying must be electrically shorted and sealed against moisture ingress as soon as they are cut. This requirement applies to all cable ends, including cables in pillars and pillar-standards, cables intended to be abandoned or temporarily decommissioned, and cables still on cable drums.

The seals and electrical shorts must not be removed until the cables are ready to be connected. Stripping of the outer sheathing of LV service cables and connection of any of the cores must not be carried out until connection of supply is required.

Where a laid cable is found to have high moisture content due to inadequate sealing, the Constructor carrying out the works must remedy this at their own cost.

13.4.2 Method of sealing

Where LV cables/service cables enter a customer's premises, the cable shall be at least single sealed to avoid the risk of water entering the premises via the cable.

A triple end seal arrangement is required for all HV cables. A triple end seal arrangement is required for all exposed LV Distributor cables. Only a single seal cap is required for LV Distributor cables which are enclosed (e.g. cables left in a LV pillar or inside a kiosk for future connection). A list of approved triple end seal kits is given in Annexure G. The triple end seals shall be constructed in accordance with the installation instruction (ESD-3410-AU-5/03 for high voltage single core

cables, ESD-3408-AU-5/03 for multicore cables and ESD-5891-AU-07/12 for low voltage single core polymeric cables) supplied in the triple end seal kit.

Completed permanent sealed ends must be laid in either suitable troughing or 1000mm lengths of UPVC conduit, and filled with sand. The sealed ends must then be buried and protected with approved polymeric cable covers. Sealed cable ends which are awaiting jointing shall be elevated clear of any free standing water in the excavation.

For polymeric insulated/polymeric sheathed service cables of cross sectional area 50 mm² or less, which are intended to be buried, a single heatshrink cap over the mastic tape may be used instead of the triple seal arrangement. The end caps used shall be selected from the approved range specified in Annexure G.

Note that cable surfaces which will come into contact with adhesive lined heatshrink components must be thoroughly cleaned, then degreased and abraded before applying the heatshrink components. Some older cables may have graphite coatings on the outer sheaths, which must be removed before the cable surfaces are cleaned. Refer to NS177 for the graphite removal procedure.

13.4.3 Safety precautions and first aid procedures for graphite coated cables

Graphite has been classified as having low toxicity, and is a non-carcinogenic substance. However, normal industrial safety precautions such as wearing leather gloves, safety glasses and safety boots should be observed.

First aid procedures are:

- Swallowed - Keep individual calm, do not induce vomiting, seek medical attention.
- Eye - Flush eyes with water for 15 minutes, seek medical attention if irritation persists.
- Skin - Wash with soap and water, remove contaminated clothing and launder before reuse.
- Inhaled - If affected, remove individual to fresh air, seek medical attention if breathing difficulties occur.

13.5 Shorting of cable cores

13.5.1 Multicore cables

The conductors of multicore cables shall be shorted out using clouts and 10 turns of 1.63mm tinned copper wire (Stockcode 68312). For stranded cables, the clouts shall be hammered into the strands. For solid-core cables, the clouts shall be inserted between the insulation and the solid cores.

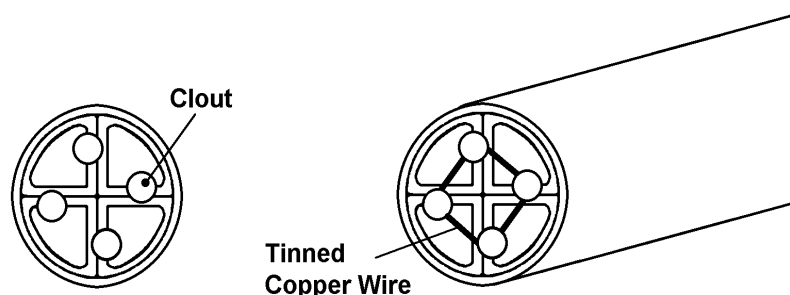

Figure 18: Shorting the cable

13.5.2 Single core neutral screened low voltage cables

Remove 35mm of the cable sheathing material and 35mm of the insulation to expose the neutral screen wires and the core conductor. Bind the concentric neutral wires to the core conductor using 10 turns of 1.63mm tinned copper wire (Stockcode 68312).

13.5.3 Single core low voltage polymeric cables 185 mm² and 300 mm²

Refer to Installation Instruction ESD-5891-AU-11/11 and stockcode 182467 for the kit.

13.5.4 Single core copper wire screened high voltage cables

Remove 50mm of cable sheathing material and 50mm of the core insulation to expose the copper wire screens and the core conductor. Bind the screen wires to the core conductor using 10 turns of 1.63mm tinned copper wire (Stockcode 68312).

13.5.5 Single core metallic sheathed PILC cables

Expose 15mm of metal sheath and clean it. Short the core conductor to the metal sheath using a clout and tinned copper wire (Stockcode 68312). Apply 10 turns of the 1.63mm copper wire to the clout and metal sheath, then tie-off the copper wire around the metal sheath.

13.5.6 11kV UGOH terminations

Where the UGOH cables have been terminated onto the termination plates but are not to be immediately connected to the overhead mains, the UGOH cables must be short circuited and earthed. Insulated black cable of not less than 25mm² copper, lugged with M12 stud hole lugs is to be used. These connections are to be made between the top of the termination plates and the surge arrester earth bar.

13.6 Cable length and joints

13.6.1 General

Cables shall be laid in the longest lengths possible (subject to the maximum drum length and the pulling tension requirements) to ensure minimum number of joints. Having an excessive number of joints in a single cable section is not acceptable.

Where a cable section cannot be laid in one continuous length and joints are necessary, the joints shall be positioned in accessible locations clear of any obstructions that have the potential to make jointing difficult or impossible.

Cable joints shall be installed in a straight section of trench with at least 2 metres of straight cable at either side of the proposed joint location to allow the joint components to be parked whilst the joint is being constructed.

Cable installation plans, and installation of cables, must avoid the positioning of cable joints within 6 metres:

- from the ends of roadway and driveway crossing conduits,
- from concrete encased conduits,
- from street corners and similar sharp bends, and
- from other locations limiting access for future joint repair/replacement.

Cable joints that are required to be installed in the carriageway shall comply with one of the following requirements:

- Proposed joint locations subjected to high traffic volumes, and which have cables installed in conduits, shall require the cable joints to be installed within a pit to the requirements of NS172. Examples of high traffic locations include CBD areas and RMS roads.
- Proposed joint locations not subjected to high traffic volumes are permitted to have cable joints direct buried under the carriageway, at a location which takes into consideration Ausgrid's future maintenance activities as determined by the Ausgrid Representative.

If the above conditions cannot be met regarding the positioning of cable joints, then the matter shall be referred to the suitable Ausgrid Representative (i.e. for contestable projects, the Contestable Project Co-ordinator, or for all other cases, the applicable Field Manager) to make a decision based on a careful study of the local site specific conditions.

Cables are to be installed with a 1.2 metre overlap at all joint positions. Where two or more cables are installed and the joints occur in the same vicinity, joints are to be staggered by a minimum of 1 metre if space is available.

Constructors shall employ sufficient controls to ensure that no damage is caused to newly laid cables, or to existing cables and infrastructure. Particular attention shall be paid during cable pulling to sections of the new cable route where there is a significant change in direction, and where the cable enters a conduit.

13.6.2 Placement of cable joints near road crossings

11kV three-to-one straight through joints and LV joints should not be located within 6m of a road crossing due to installation issues with respect to bending radii limitations of the cables. The joints required may be for a UGOH or cable terminations at a kiosk substation. Designers are to make sure that these requirements are met wherever practicable. The joints should be located away from the exclusion zone given in yellow colour in Figure 19 below.

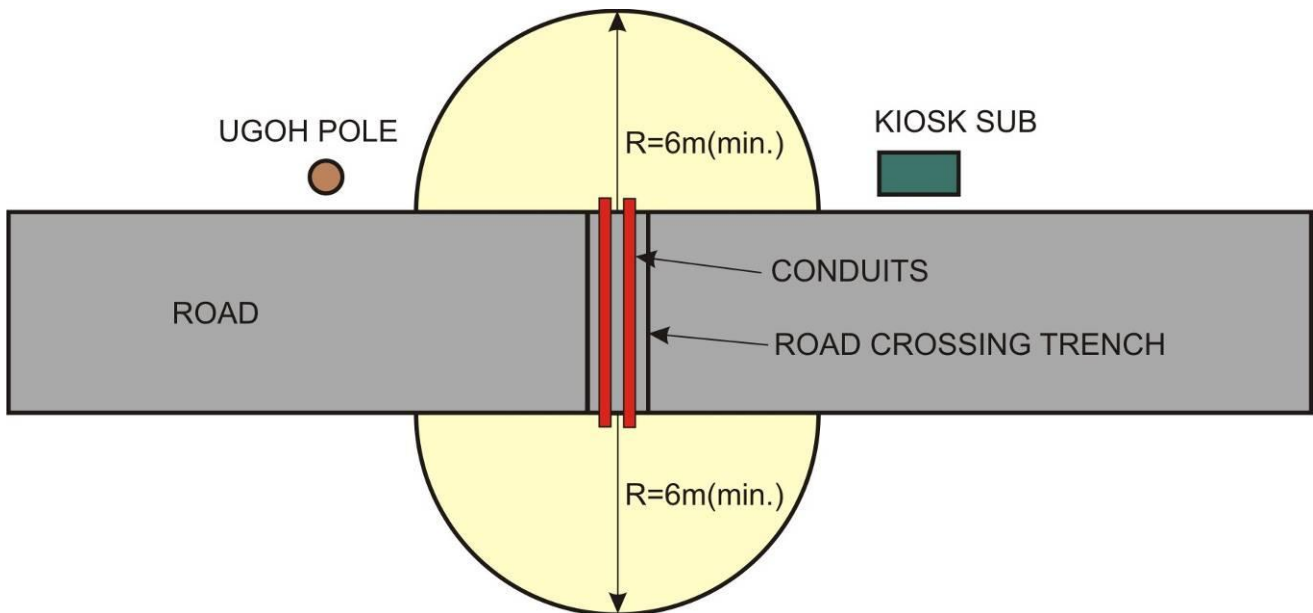

Figure 19

13.6.3 Joints within the Cable Basement of Zone Substation Buildings

Joints within the cable basement of zone substation buildings should be avoided in order to minimise the risk of a joint failure damaging adjacent cables or initiating a fire. This can be achieved by the selection of a cable type to eliminate the need for a joint altogether. Where a dedicated cable joint pit is present and space is available, all joints shall be located in the cable joint pit.

Where joints are required to be located within the cable basement, the risk of doing so shall be mitigated by application of the controls detailed in NS171 Fire Stopping in Substations. The Designer shall specify the exact location and controls for the joint to be constructed in the cable basement on their design.

A System Alteration Order shall clearly identify the cables (by panel number) that have been protected with the controls detailed in NS171.

13.7 Joint bays

Joint bays are the most likely section of a project to be re-excavated, and these locations shall be filled with compacted, well graded standard bedding material as per Clause 10.16.1.

Coarse aggregates must not be used in joint bays due to risk of damage to the cable during compaction.

Concrete or TSB shall not be used as a bedding material around direct buried cables in joint bays. Refer to Clause 13.3.

13.8 Damage to cables during construction

Cables must not be stood on, and any sharp tools or objects are to be removed from the vicinity of cables being laid in order to avoid damaging them.

Any cable or general infrastructure damages that are discovered or caused as a result of laying a new cable shall be reported immediately to Ausgrid. Once inspected, Ausgrid will determine the method of repair.

A suitable site specific risk assessment shall be completed and implemented to manage the risks associated with cable pulling activities. The risk assessment shall include prevention of harm to people, and prevention of damage to the cable being pulled and adjacent asset(s).

Ausgrid may decide, at its discretion, to carry out electrical tests on newly installed cables to check for sheath integrity if it is suspected that such cables have been damaged during cable pulling. Testing will be carried out in accordance with NS161 at the Constructor's expense.

13.9 Bending radii of cables

The internal bending radius of the cable being laid shall not be less than the cable manufacturer's specification. Table 7 is based on the cable manufacturer's specification. Nominal minimum internal bending radii are provided in Tables 8 and 9 as a guide.

The persons carrying out the works must determine the exact minimum internal bending radius for cables before they are laid if it is envisaged that the actual bending radius will be close to the nominal minimum specified in the table.

When selecting an approved conduit bend the 'during installation' minimum internal bending radius in Table 7 shall be used to calculate the minimum conduit bend radius.

Table 7: Minimum Internal Bending Radii for LV and 11kV Cables

Cable type	Minimum Internal Bending Radius	
	During Installation	After Installation
Polymeric insulated cables		
All Low Voltage cables with circular stranded conductors		
Less than or equal to 25mm diameter	6D	4D
Greater than 25mm diameter	9D	6D
All Low Voltage cables incorporating sector shaped conductors, Solid Aluminium or compacted	12D	8D
11kV HDPE sheathed cables	25D	15D
11kV Composite HDPE and PVC sheathed cables	25D	15D
11kV Triplex Composite HDPE and PVC sheathed cable		
Bundled cable	15D	10D
Phase cable	25D	15D
11kV nylon sheathed cables	30D	20D
Nylon sheathed pilot cables	30D	20D
Paper insulated cables:		
11kV multicore, lead sheathed, PVC oversheathed	18D	12D
11kV multicore, lead sheathed, HDPE oversheathed	25D	15D
11kV single core, lead sheathed, PVC oversheathed	22D	15D

Note: “D” is the overall diameter of the cable in mm or the circumscribing overall diameter of a bundled cable.

The minimum internal bending radius of each core of a three core polymeric cable after it has been trifurcated is 15D, where D is the diameter of the re-jacketed individual core. Refer to Table 9 for more details.

Table 8: Nominal Minimum Internal Bending Radii for Specified Cables (Guide Only)

Cable type	Minimum Internal Bending Radius	
	During Installation (mm)	After Installation (mm)
LV XLPE insulated cables:		
185 CU1 XQ Z	145	95
185 CU1 XQ Z /COM/ 4 CABLES (Parrot cable)	270	180
240 CU4 XQ Z	675	450
240 AL4 XQ Z/SAC	590	395
300 AL4 XQ Z/SAC	655	435
300 CU1 XQ Z	270	180
500 CU1 XQ Z	335	225
11kV TRXLPE insulated cables:		
35 AL1 TRXQ 16 CU(WS) YQ	555	330
70 CU1 TRXQ 16 CU(WS) YQ	620	370
95 AL3 TRXQ 16 CU(WS) Z YQ	1380	830
150 CU3 TRXQ 35 CU(WS) Z YQ	1610	965
185 CU1 TRXQ 70 CU(WS) Z YQ	825	495
185 CU1 TRXQ 70 CU(WS) Z YQ/Triplex	1120(Bundled) 870 (Phase)	745(Bundled) 525 (Phase)
185 AL3 TRXQ 35 CU(WS) Z YQ	1700	1020
300 CU1 TRXQ 70 CU(WS) Z YQ	955	570
300 CU1 TRXQ 70 CU(WS) Z YQ/Triplex	1275(Bundled) 960 (Phase)	850 (Bundled) 575 (Phase)
300 CU1 TRXQ 150 CU(WS) Z YQ	990	595
300 AL3 TRXQ 35 CU(WS) Z YQ	1980	1190
400 AL3 TRXQ 35 CU(WS) Z YQ	2180	1305
500 AL3 TRXQ 35 CU(WS) Z YQ	2310	1385
500 CU3 TRXQ 35 CU(WS) Z YQ	2315	1390
630 CU1 TRXQ 120 CU(WS) Z YQ	1245	750
11kV Paper insulated cables:		
300 CU3 P H L YQ	760	640
Nylon sheathed Pilot cable:		
1.5CU4QQZNY/TR (Nylon Translay)	420	280

Table 9: Nominal Minimum Internal Bending Radii for the Individual Cores of the Three Core Polymeric Cable (After Trifurcation) - Guide Only

Cable type	Minimum Internal Bending Radius
	After Installation (mm)
11kV XLPE and TRXLPE insulated cables:	
95 AL3 TRXQ 16 CU(WS) Z YQ	410
150 CU3 TRXQ 35 CU(WS) Z YQ	440
185 AL3 TRXQ 35 CU(WS) Z YQ	490
300 AL3 TRXQ 35 CU(WS) Z YQ	535
400 AL3 TRXQ 35 CU(WS) Z YQ	580
500 AL3 TRXQ 35 CU(WS) Z YQ	630
500 CU3 TRXQ 35 CU(WS) Z YQ	660

13.10 Cable pulling equipment

The pulling tension on power cables shall not exceed the cable manufacturer’s specification. Approved cable pulling lubricants may be used to reduce the cable pulling tension. Refer to Annexure E for guidelines on maximum pulling tensions, cable pulling lubricants and the use of pulling eyes.

A documented site specific cable pulling plan shall be completed by a competent person and provided to Ausgrid. The completed site specific cable pulling plan shall be implemented for the cable pull.

Where there is the potential for damage to other cables or to critical network infrastructure within the vicinity of the cable pulling equipment (if it was to fail under load), appropriate barricading and/or protective screens shall be put in place to protect the identified components.

Only load rated attachment points shall be used when pulling cables into the substation cable marshalling areas, unless otherwise approved in writing by Ausgrid.

The pulling tension being used shall not exceed the rated working load limit (WLL) of the cable pulling equipment proposed.

Appropriate rope tension fuses shall be used between the pulling rope and the stocking/pulling eye for each cable pull where a power driven winch is used. Alternatively, a strain gauge with control mechanism and logging capability shall be used.

If strain gauge is used with rope tension fuses, then the logging capability is not required as the rope tension fuses will not allow to exceed the maximum pulling tension.

If the strain gauge is used without rope tension fuses, then the control mechanism of strain gauge should ensure that the maximum pulling tension has not been exceeded throughout the entire pulling process. Applied tension values should be able to be checked during and after the pull in this method.

The cable pulling rope must be equipped with a swivel and attached to the cable by a stocking unless pulling eyes have been fitted to the cable.

The pulling rope shall be made of synthetic material. The rope shall have high strength and high abrasion resistance, e.g. Donaghy’s Aquatec® rope. The selected rope must be rated to withstand the calculated pulling tension. The rope must not be tensioned beyond its design limit to avoid the risk that it may snap or damage the conduit during a cable pull (e.g. by slicing the conduit wall).

The plant used to pull cables shall be firmly anchored before a pull commences to prevent uneven tension on the cable due to winch movement. Prior to securing any floor mounted pulling equipment to the substation floor in accordance with the manufacturer's instructions, written advice shall be obtained from a competent person (i.e. a Civil / Structural Engineer) regarding the structural integrity and load capacity of the substation floor, and the suitability of the anchoring method proposed. The cable shall be drawn smoothly into position with a minimum of stops and at a maximum speed of 12-15 metres per minute. The cable drum shall be placed so that the cable is pulled from the top of the drum.

On completion of a cable pulling operation, all cable ends shall be inspected for damage. The length of cable laid shall be extended to compensate for damaged cable ends.

13.11 Use of existing spare conduits

Ausgrid has existing spare conduits as part of its underground infrastructure. The depth of cover of these conduits generally varies between 450mm and 750mm.

Spare conduits are intended to be used to get around the need to re-excavate. The depth of cover of the conduits should be consistent with the requirements of the cables being laid (refer to Section 10). Ausgrid is not responsible for or warrants the location & condition of existing spare conduits or that the existing spare conduits are fit for intended purpose.

Where high voltage conduits are not available, pulling of high voltage cables into low voltage conduits may be allowed at the discretion of Ausgrid's Representative, provided the depth of cover is consistent with the requirements for high voltage cables (refer to Section 10). Permission to use the conduits must be obtained in advance of their use.

Spare conduits shall not be used in any location where excavation is required to lay adjacent parallel cables. Ausgrid may also reject an application to use existing spare conduits if a need is foreseen to use the conduits for other purposes.

For existing conduits which have been installed under reduced cover, a case-by-case approach shall be carried out by Ausgrid to determine the suitability of the conduits (e.g. safety risk, cable ratings, mechanical loads) for cable installation.

Some of the existing conduits are made of asbestos cement and appropriate asbestos handling methods shall be used.

13.12 Excavations and cable chases

Where cables are to be installed in excavations and cable chases, cable rollers are to be used to support and guide the cables. Rollers must not be located more than 3 metres apart and positioned to prevent excessive side wall pressure on the cable. Where the cable is to be pulled around corners or angles, special corner rollers are to be used. The cable must not enter or leave any cable roller at an excessive angle, or exceed the cable manufacturer's recommendations for minimum internal bending radius.

13.13 Cable installations involving jointing pits

The maximum point load (working load) of a conventional pulling eye fitted to the wall of a jointing pit is 50kN. For cable pulls that are expected to exceed 50kN, two or more pulling eyes may be utilised (if available) with the use of slings between them. The strength of the pit wall should be checked before two eyes are installed.

Note: Cables and cable joints in jointing pits must not be walked on for safety and operational reasons.

When installing cables into or through jointing pits that have existing cables, precautions must be taken prior to commencing work to avoid damaging these cables. All existing cables are to be covered with protective mats (Refrasil mats) or any other method approved by Ausgrid, and these mats must be secured in position to prevent dislodgment.

Cables should not be damaged on the pit entry when installing cables into cable pits. Cables and joints should not rest on or make contact with other joints in the pit.

Where existing conduits have cables installed and are not fitted with bellmouths at the cable pit entry, a “split type” bellmouth should be installed where it is safe to do so. This may require cables to be de-energised and/or isolated.

Cables for which the existing supporting structure is to be removed in order to allow the new cables to be installed, shall be temporarily supported so that no movement occurs to the cable and associated cable joints while the existing support is removed. All temporary supports are to be of non-metallic materials. Refer to Clause 8.1 for further information regarding cable supporting requirements.

On completion of the cable installation, the existing supporting system is to be restored.

Consideration must be given to cable management in pits to ensure the safe and efficient access and emergency egress for personnel and equipment. This is achieved through the use of thorough job planning, and use of cable stands, tray, cleats, etc. Cable pits shall be kept clean by removing all scrap joints, cable and materials, debris, and general rubbish from the pit at the conclusion of works.

13.14 Installing cables in substations and switching stations

13.14.1 General

Refer to Ausgrid’s Electrical Safety Rules for restrictions on entering Ausgrid premises.

Where cables are to be installed in substations and switching stations, Ausgrid’s Representative must be requested to arrange access. Notice for access is required at least 7 days prior to commencing work in order to allow the necessary screens and protective devices to be installed.

All cables installed in substations and switching stations shall be designed to meet the distribution network rating requirements.

Weatherproof labels shall be attached to all cable ends installed in substations or future substation sites detailing the location of the remote cable ends (e.g. Cable 1, joint bay O/S 24 Smith St. on one end Cable 1, joint bay O/S 72 John St at the other end). Labels shall be marked with a permanent waterproof marker.

13.14.2 Cable labelling

Multiple cable installations shall have the cables identified as “cable 1”, “cable 2”, “cable 3” etc to assist identification. Labels must be removed upon commissioning of cables or modified at the new cable ends in the case of in-line joints carried out before commissioning.

During cable installation, the cables shall be labelled as shown in the design drawings. The cable identification labels must be placed on the cable ends at the termination points and in joint bays.

For example, a design drawing will show the cable labels at termination points as follows:

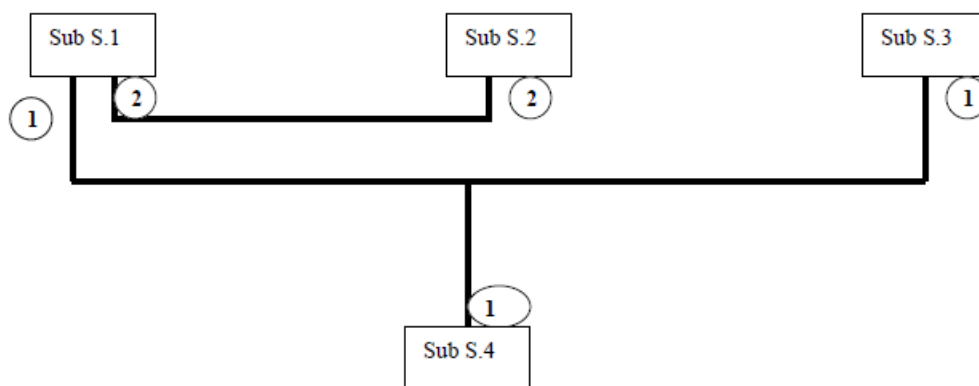

Figure 19a

Whilst the design drawing does not show the joint bay locations as they are determined at construction stage, cables must be labelled in the joint bays with respective cable labels as shown below:

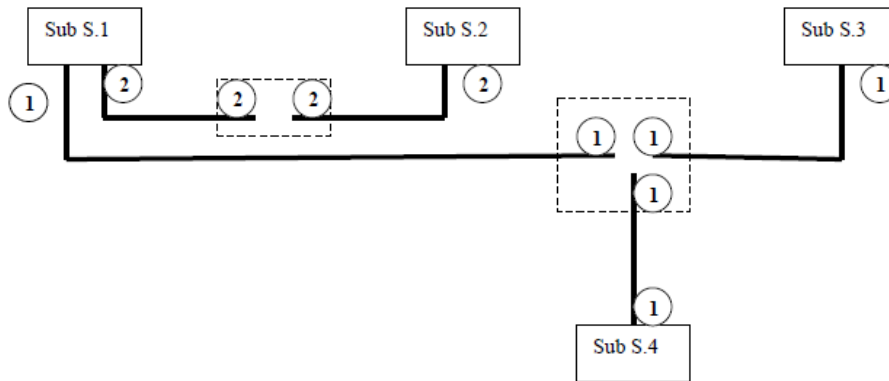

Figure 19b

The Certified design/Design drawing will include the following in the Important Note section:

“For identification and jointing purposes, all cable ends shall be labelled at the termination locations and in joint bays during cable installation. The cables must be labelled as per certified design/design drawing.”

13.14.3 Installing cables in kiosk type substations

To minimise bending of terminating cables:

- All High Voltage cables shall be laid so that they enter perpendicular to the High Voltage infill panels and vertically up inside the HV cable entry area of the kiosk. All Low Voltage cables shall be laid as per the range of acceptance entry angles as per the diagram given below.
- The internal bending radius of the cable being laid shall not be less than the cable manufacturer’s specification. The cable manufacturer’s specifications are based on Tables 8 & 9.

Ausgrid will not accept excessive bending of cables.

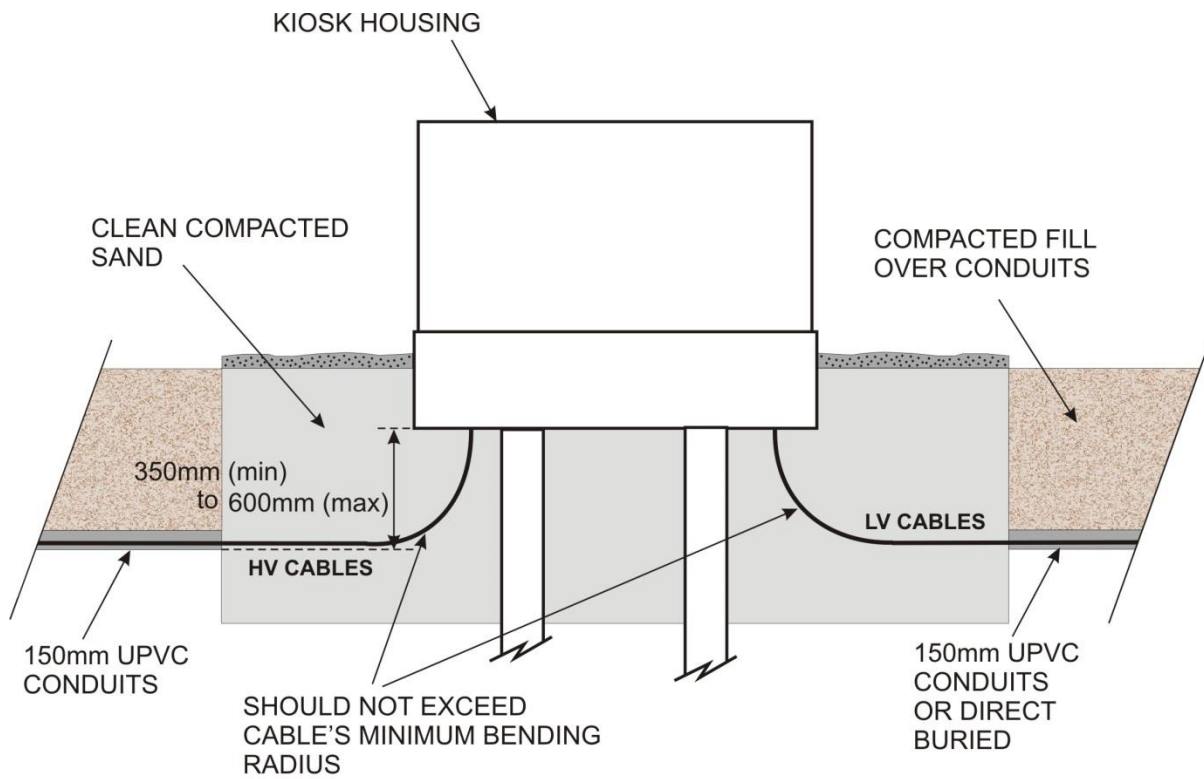

ELEVATION

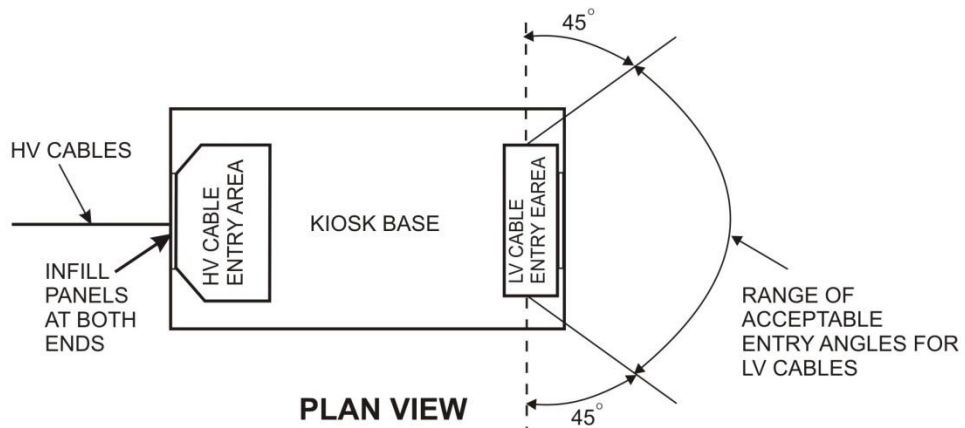

PLAN VIEW

Refer to drawings 151573, 151572 and 151190

Installing cables on kiosk type substations

Figure 20

13.15 Installing cables in cable risers

Cables installed in cable risers shall be clamped at a maximum of 1 metre intervals using approved cable clamps. Clamps shall be free from sharp edges and burrs. To prevent local heating of cables caused by eddy currents, clamps shall be either made of non-ferrous materials or where they are made from ferrous material the two halves shall not touch at both sides, and shall be fixed together using non-ferrous bolts, nuts, and washers. Cable clamps can be directly bolted to cable riser walls, or to Unistrut-type supporting channels.

13.16 Clamping of 11kV paper insulated cables

Paper cables may be clamped using either hardwood or metal clamps. The internal diameter of hardwood clamps shall be chosen such that the overall diameter of the cable is marginally larger than the internal diameter of the clamp so that when the clamp is tightened the pressure is distributed evenly without deforming the cable.

13.17 Clamping of 11kV polymeric insulated cables

Cables shall be appropriately clamped to ensure that:

- they are firmly held in position;
- the clamps carry the weight of the cable(s) if the latter are not supported on trays;
- the cables are sufficiently restrained to stop them from whipping around under fault conditions;
- the clamps are not over-tightened to the extent that they damage the cable, particularly under cyclic loading.

Polymeric cables have a relatively high thermal coefficient of expansion and will soften when operating at high temperatures. If a polymeric cable is clamped too tightly when it is installed, the polymeric insulation may permanently deform when the cable heats up resulting in a reduction in the insulation thickness.

Another possible cable damage that could occur as a result of over-clamping is that the screen wires could be forced through the insulation screen and into the polymeric insulation. Therefore, clamps shall be tightened only to the extent necessary to ensure that the cables are held firmly in place.

Where single core cables are used, the cables shall be laid and clamped in a trefoil configuration unless specified otherwise. The following also applies:

- Where single core cables are clamped in a trefoil configuration, the clamps used must be sufficiently robust to withstand the potential repulsive forces acting on individual phase cables under fault conditions. Clamps utilising magnetic material can be used for clamping single core cables in a trefoil configuration, as magnetic fields generated by the three currents cancel each other out.
- Where single core cables are required to be clamped individually in a flat formation, the clamps shall be of a non-magnetic material to prevent localised heating of the cores due to the closed magnetic circuit of the clamp.

Clamps approved by Ausgrid are listed in Table 10. All cable clamps shall be used with a nitrile or neoprene rubber-cushioning strip of minimum thickness 3mm, wrapped around the cable assembly.

Other clamps may be acceptable subject to Ausgrid's Representative's approval. Examples of the approved clamps are shown in Figure 21 below.

Table 10: Cable Clamps for Polymeric Cables

Installation Environment	CABLE SIZE (mm ²)						
	70 Cu 1	185 Cu 1	300 Cu 1	630 Cu 1	300 Al 3	400 Al 3	500 Al 3
Flat on trays	ABB:EA-UKR100	ABB:EA-UKR100	ABB:EA-UKR100	ABB:EA-UKR100	ABB:EA-UKR100	ABB:EA-UKR100	ABB:EA-UKR100
Trefoil on trays	UNISTRUT: TF27	UNISTRUT: TF37	UNISTRUT: TF41	ABB:EA-UKR200*	-	-	-
Flat, perpendicular to Unistruts (in substations, High-rise buildings etc)	UNISTRUT: P2031SS	UNISTRUT: P2033SS	UNISTRUT: P2035SS	UNISTRUT: P2039SS	UNISTRUT: P2049SS	UNISTRUT: P2051SS	UNISTRUT: P2055SS
Trefoil, perpendicular to Unistruts (in substations, High-rise buildings etc)	UNISTRUT: TF27	UNISTRUT: TF37	UNISTRUT: TF41	IdTechnik - KP39/53	-	-	-
Flat, at an angle to Unistruts	ABB:EA-UKR100	ABB:EA-UKR100	ABB:EA-UKR100	ABB:EA-UKR100	ABB:EA-UKR100	ABB:EA-UKR100	ABB:EA-UKR100
Trefoil, at an angle to Unistruts	ABB:EA-UKR100	ABB:EA-UKR100	ABB:EA-UKR100	ABB:EA-UKR200*	-	-	-
Trefoil, freestanding	UNISTRUT: TF27	UNISTRUT: TF37	UNISTRUT: TF41	IdTechnik - KP39/53	-	-	-
Individual or trefoil on UGOHs	ABB:EA-UKR100	ABB:EA-UKR100	ABB:EA-UKR100	ABB:EA-UKR200*	ABB:EA-UKR100	ABB:EA-UKR100	ABB:EA-UKR100

* Note: EA-UKR200 is supplied with one bracket. Use an additional bracket (ABB part number EA-B200) on trefoils of large cables such as 630 mm² polymeric cable.



ABB: EA-UKR100



ABB: EA-UKRB200 (See *Note above)



UNISTRUT: P Series (Stainless Steel)



UNISTRUT: TF Series



IdTechnik: KP Series



Nitrile rubber liner to be used with all clamps

Figure 21: Approved Cable Clamps

13.18 Underground to overhead transition points

Low voltage underground to overhead transition points are to be installed in accordance with NS127, Low Voltage Cable Joints and Terminations.

High voltage underground to overhead transition points are to be installed in accordance with NS129, 11kV Joints and Terminations - Paper Insulated Lead Covered Cables and NS177, 11kV Joints (including Transition Joints) and Terminations - Polymeric Insulated Cables.

13.19 Standard depth of cover

Standard depth of cover over direct buried cables shall be in accordance with Clause 10.11. Note that Clause 4.4 requires all road crossings or cable installations in roadways to be installed in conduits, so this clause only applies to direct buried cables for footway installations.

13.20 Reduced depth of cover

The portions of cables in a cable run subject to reduced cover shall be laid in conduits, and shall comply with the requirements of Clause 10.12.

13.21 Installation of underground cables in the vicinity of poles

A 350mm exclusion zone shall be maintained between underground cables and poles. Only UGOH cables erected on the pole are to enter this zone and must leave the pole as depicted in the Figure 22 below. The purpose of the exclusion zone is to reduce any risk of damage to underground cables due to excavations for pole inspection work.

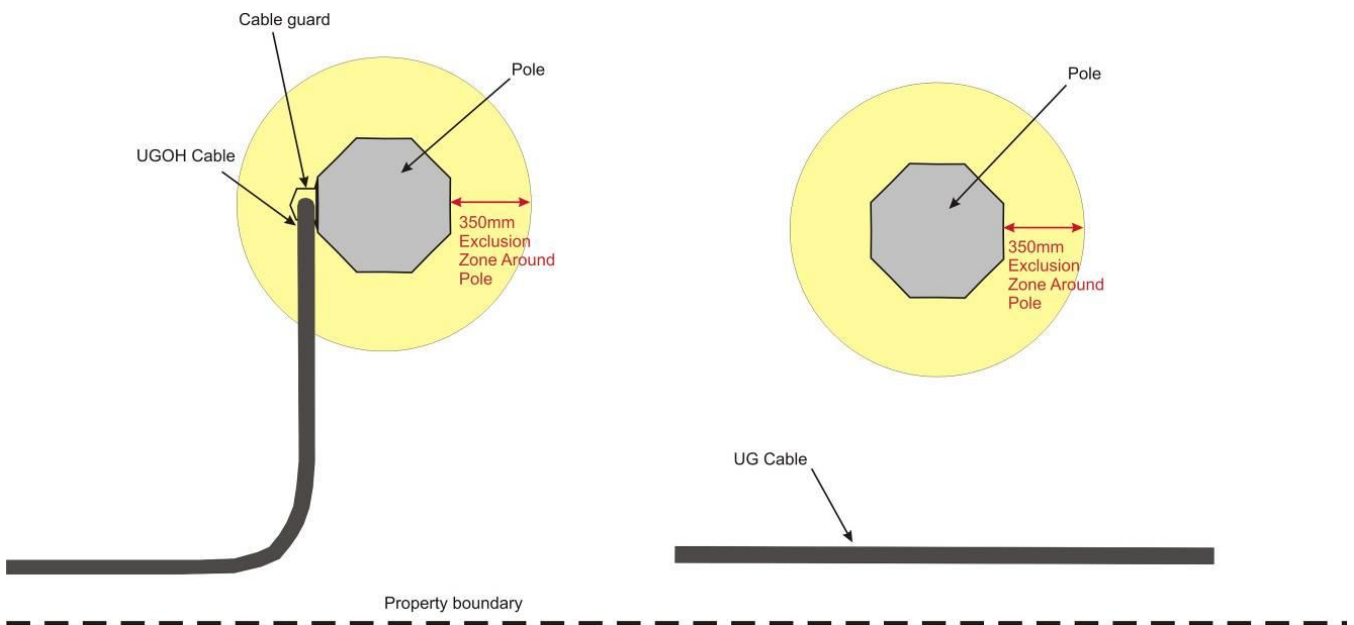

Figure 22: Installation of Underground Cables in the vicinity of poles

13.22 Clearance to other utility services

Clearances to other assets should generally be in accordance with the NSW Streets Opening Coordination Council (SOCC) Guide to Codes and Practices for Streets Opening; however, the construction of Ausgrid assets (including excavation, installation and backfill) at any time in the vicinity of other utility infrastructure must be undertaken with an appropriate risk assessment by those carrying out the work.

The onus shall be on the Constructor not to damage another utility's infrastructure. This may include consultation with the other utility.

14. BACKFILLING OF EXCAVATIONS

14.1 Backfill material

14.1.1 General

Ideally, the backfill material should restore the sub-grade to its original condition, which may be achieved by replacing the excavated materials in the same position from which they were excavated, and in the same state with regard to moisture content and compaction. This is usually difficult with "moisture unstable" soils. Where these exist under heavy traffic pavements, it will generally be required to import granular material that is capable of spreading the traffic load over a larger area of sub-soil.

14.1.2 Roads and Maritime Services requirements

In general, backfilling materials shall be to the satisfaction of the Roads Authority (Local Council or RMS). Where Ausgrid or the relevant Roads Authority considers the backfilling material unsuitable for a particular project, this material shall be removed and replaced by material which is considered suitable by that Authority.

14.1.3 Additional Ausgrid requirements

Trenching can alter or even divert existing sub-surface drainage to concentrate sub-surface water with disruptive scouring effects where flow occurs. In the selection of backfill material this aspect shall be taken into account in relation to the nature and topography of the particular location.

Where sub-surface water flow exists or is likely to occur (e.g. steep inclines) or where sand is used as backfill material, suitable water barriers shall be provided in the trench, spaced at regular intervals appropriate to site conditions.

Approved water barriers are bulkheads consisting of bags packed with 20:1 sand/cement mix. Persons working on the network must comply with the guidelines relating to the seepage of water found in 1152.3.8 Backfill.

14.2 Backfill in landscape areas

The Constructor must carry out backfilling in landscape areas as specified in 1152.3.8 Verge and landscape areas.

14.3 Backfill to subgrade level under footpaths, carriageways and heavy duty driveways

The Constructor must comply with the guidelines in 1152.3.8 Under footpaths, carriageways and heavy duty driveways.

14.4 Compaction of trench backfill

Compaction of trench backfill shall be carried out by the Constructor in accordance with 1152.3.9 and Annexure I.

Frequency of compaction testing shall be in accordance with Section 16.

Ausgrid reserves the right to witness any or all of the compaction tests.

14.5 Disposal of surplus materials

Surplus materials and rubbish must be disposed of lawfully.

14.6 Record keeping requirements

The Constructor shall maintain accurate records of the type and source of materials used for backfilling at every site and shall produce such records to Ausgrid on demand. The records shall be kept for a minimum period of three years after completion of the works.

14.7 Testing of conduits

After installation and backfilling of a bank of conduits, Ausgrid’s Representative is to be notified to witness conduit testing.

All new conduits shall be thoroughly cleaned and an approved solid mandrel of diameter 12mm less than the internal diameter of the conduit and minimum 230mm in total length and minimum 130mm in flat length, shall be pulled by hand or with winch/machine (with suitable sized fuse) through every conduit in both directions to ensure their integrity.

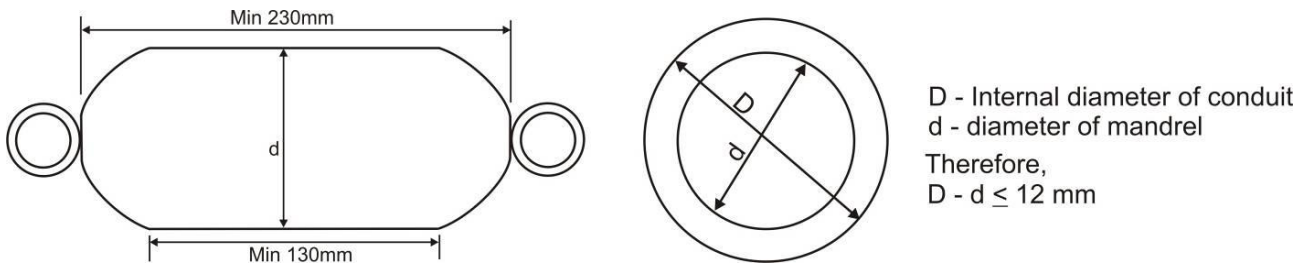

Figure 23

After passage through each conduit, the mandrel shall be thoroughly inspected for cuts or damage. If in the opinion of Ausgrid’s Representative, there is any doubt as to the freedom from foreign material or any object or defect that may cause damage to the cable in the conduit, the Constructor shall repeat pass the mandrel through the conduit(s) until the Ausgrid Representative is satisfied.

Ausgrid reserves the right to request that a waste length of the cable to be installed be passed through the conduits, or video cameras be used to inspect the conduits where reasonable concern exists as to the condition of the conduits or if they have been backfilled without Ausgrid's Representative being present.

Conduits found to have defects which, in the opinion of Ausgrid’s Representative, may cause damage to cables shall be repaired by the Client / Constructor at no cost to Ausgrid and at a time nominated by Ausgrid’s Representative. Several commercial conduit repair systems are available.

15. REINSTATEMENT OF PAVEMENTS AND PATHWAYS

15.1 Temporary reinstatement

15.1.1 Reinstatement requirements

Unless final reinstatement is intended to be carried out immediately after completion of backfilling, temporary reinstatement of pavements and pathways shall be carried out.

All temporary restorations in carriageways and pathways must be of sufficient quality and must be maintained as such to ensure the safety of the site for pedestrians and vehicular traffic.

The Contractor shall be responsible for temporary line marking that is damaged or removed by the cable laying project. Line and road marking that is required for the safety of vehicles and the public must be installed temporarily as a minimum before the opening of the road for the carriage of traffic. The Contractor must ensure that temporary road marking is maintained and is suitable for its purpose until replaced by permanent line and road marking's.

Surfaced driveways and footpaths - Temporary reinstatement must be carried out by the Constructor in accordance with 1152.3.11 Temporary footpaths and driveways.

Surfaced roadways controlled by Local Councils (except those carrying heavy traffic) - Temporary reinstatement must be carried out by the Constructor in accordance 1152.3.11 Temporary carriageways.

Surfaced roadways controlled by the Roads & Maritime Services (RMS) of NSW - Temporary reinstatement must be carried out by the persons carrying out the works in accordance RMS Specification M209.

15.1.2 Temporary steel road plates

All steel road plates shall comply with RMS Specification M209 or the Australian Standard as applicable.

15.1.3 Road furniture

The Contractor is responsible for installation of road furniture that is damaged or removed by the cable laying project. Road furniture that is required for the safety of vehicles and the public must be installed temporarily as a minimum before the opening of the road for the carriage of traffic. All road furniture must be replaced like for like using current industry practice and approved materials and techniques and in accordance with the manufacturer's instructions. The Contractor must ensure that temporary road furniture is maintained and is suitable for its purpose until replaced by permanent road furniture.

15.2 Final reinstatement

Other than for State Roads, the Client shall arrange for permanent reinstatement which complies with 1152.3.12 – 3.14.

For State Roads, the Client shall arrange for permanent reinstatement which complies with RMS Specification M209.

16. FREQUENCY OF TESTING OF BACKFILL AND TEMPORARY RESTORATIONS

The frequency of testing of backfilling and temporary restorations shall be as specified in Table 11, unless directed otherwise by Ausgrid. Refer to Annexure I and Section 25 for definitions of the various layers.

Test reports shall be supplied to Ausgrid's Representative for approval as part of the project sign-off process.

Ausgrid may also conduct random audits on the quality of backfill and compaction. Should these audits indicate improper backfilling and compaction, Ausgrid may impose a higher level of testing.

Where final compaction tests indicate that the required percentage of maximum density has not been met, the Constructor must perform further compaction tests at one metre intervals either side of the failed test until two consecutive compaction tests pass on either side of the failed test. The Constructor must re-compact the area of the failed tests and perform the compaction tests again. This process must be repeated until the required compaction level is achieved over the entire length of failed tests.

Where there has been more than one test that has not met the required percentage of maximum density at the same Site, then the Constructor is to carry out such other number of tests that Ausgrid's Representative deems necessary, at no cost to Ausgrid.

Any defects in the quality of backfill or compaction shall be rectified by the person doing the work at no cost to Ausgrid.

Table 11: Frequency of Testing of Backfill and Temporary Restorations

Activity to be Tested	Key Quality Verification Requirements	Maximum Lot Size	Minimum Test Frequency (see note 5)	Test Method
Materials supplied for trench backfill under carriageways, footpaths, and all joint holes	Material properties as specified	1 contract	1 per contract or source of supply for each type of material used or suppliers test certificates	As specified
Materials supplied for sub-base and base layers	Material properties as specified	1 contract	1 per contract or source of supply for each type of material used or suppliers test certificates	As specified
Trench and joint bay backfill and sub-base and base under carriageways, heavy duty vehicular crossings and car parks	Compaction	1 continuous trench or 1 joint bay or one road crossing	1 per layer, per 30 metre length per trench (see note 6)	AS 1289.5.1.1 AS 1289.5.2.1 AS 1289.5.6.1
Trench backfill and sub-base and base under footpaths, light/medium duty driveways and turfed areas	Compaction	1 project (see note 1)	1 per layer, per 100 metre length of trench or part thereof (see notes 2 and 3)	AS 1289.5.1.1 AS 1289.5.2.1 AS 1289.5.6.1
Backfilling of individual joint bays in footways (see note 3)	Compaction	1 joint bay (see note 4)	1 per layer	AS 1289.5.1.1 AS 1289.5.2.1 AS 1289.5.6.1
Backfill of trial holes (Including location of conduit ends) (see note 3)	Compaction	1 trial hole	1 per layer	AS 1289.5.1.1 AS 1289.5.2.1 AS 1289.5.6.1

Activity to be Tested	Key Quality Verification Requirements	Maximum Lot Size	Minimum Test Frequency (see note 5)	Test Method
Materials supplied for temporary road surface (or sealing material)	Material properties as specified	1 contract	Supplier test certificates	As specified
Temporary road surface placement	Compaction	1 project (see note 1)	Check evenness and camber of all restored surfaces	As specified in Section 15

Notes:

1. 'Project' refers to the works executed within a reasonable timeframe by the same contractor as part of a single Certified design/Design plan. Where a Certified design/Design plan involves two or more well-defined stages, and each stage is executed separately, each stage shall be regarded as a separate project for the purpose of testing frequency.
2. The length of trench backfilled shall be taken to be the total of all discrete excavations backfilled together by the same Constructor.
3. Joint bays and trial holes backfilled and compacted concurrently with cable trenches shall be regarded as cable trenches for the purpose of testing frequency.
4. Individual joint bays shall be taken as those which were part of a cable trench but were backfilled separately from this trench, or any discrete joint bays which were not associated with any other cable trenches.
5. A layer is defined in 1152 or RMS Specification M209 depending on the location.
6. Every separate trench in a roadway or carriageway must have at least one compaction test. For example; if there is a requirement for two road crossings of 10m each, a compaction test is required for each road crossing.

17. CABLE JOINTING

Jointing work on the electrical distribution system and details of the joints and terminations required, are referenced in NS127 LV Cable Joints and Terminations, NS129 11kV Joints and Terminations - Paper Insulated Lead Covered Cables and NS177 11kV Joints (including Transition Joints) and Terminations - Polymeric Insulated Cables.

18. CABLE TESTING REQUIREMENTS

On completion of the works and immediately before the transfer of works to Ausgrid, all cabling involved in the project must be tested in accordance with Ausgrid's publication NS161 Testing of Underground Cables after installation.

Any defects identified by the tests must be rectified at the Constructor's cost, and the cables must be re-tested.

The Constructor must coordinate the works and tests to allow transfer and/or commissioning immediately after passing final testing.

The provisions of Section 19 of this Network Standard concerning protection of exposed underground construction shall be observed at all times.

19. PROTECTION OF EXPOSED UNDERGROUND CONSTRUCTION

Access permits* for work on 5kV or 11kV underground cables shall not be signed off and withdrawn, whether for testing, commissioning or re-energisation of the cables, unless:

- All new or repaired cable joints are backfilled or sand-bagged, and
- Excavations in the immediate proximity of substations are backfilled, and
- All other excavations are safely barricaded and protected, and arrangements are put in place for regular checking to ensure that they remain safely barricaded and protected.

(*Ausgrid's Electrical Safety Rules cover access permit procedures and requirements).

20. CABLE TUNNELS

For dedicated Ausgrid cable tunnels, specific fire engineering solutions shall be provided that deal with cable type, cable joints, fire detection, fire suppression, ventilation, emergency response and other aspects. Installed cables within dedicated Ausgrid cable tunnels will generally include an additional layer of low smoke zero halogen (LSOH) material over the normal HDPE over-sheath, to retard the spread of fire and smoke.

The design of cable installations in cable tunnels shall be approved by Ausgrid prior to proceeding with construction works.

20.1 Shared Cable Tunnels

This clause outlines the requirements for Ausgrid cables used in shared services tunnels. These are locations where other authorities (e.g. water, sewer, gas, communications), or other parties, use the tunnel void to carry their services, and have shared access arrangements for the tunnel.

The preferred approach for Ausgrid cables in shared services tunnels is to implement the requirements of Annexure J for the installation of network ductlines through buildings. This will ensure that adequate security and protection measures are provided for Ausgrid's assets, and that any potential Ausgrid impacts on other services will be minimised.

Where this approach is not reasonably practicable, it will be necessary to address the risk of fire propagation in the tunnel initiated by a joint or cable failure. In this case, the following requirements are to be met:

1. Cable Type:

- Fire retardant (low smoke, zero halogen or LSOH), HDPE sheaths shall be used on all power cables in tunnels. Where this is not feasible, a fire retardant cable wrap or cable coating shall be used to protect a conventional power cable.
- The LSOH cable shall extend into the next underground joint bay, or into the substation, up to the terminations, as applicable.

2. Cable Support, Protection and Signage:

- Ausgrid's HV cables should be separated as much as possible from Ausgrid's LV cables.
- Ausgrid's HV and LV cables shall be carried on dedicated cables trays (or equivalent), in an elevated location if possible, and separated as much as possible from any existing LV cables, communications cables, services etc that are owned by others.

- Where additional security/mechanical protection is required, a fixed lightweight wire cage or barrier around the cable tray that can be removed in sections should be provided. This approach is comparable to that used on accessible bridge crossings to protect major HV cables.
- Clear signage shall be provided indicating that the cables are HV and are owned by Ausgrid.

3. Cable Joints:

- Cable joints within the tunnel should be minimised.
- Where joints are essential, encapsulation and/or local protective shields shall be used in consultation with Ausgrid to minimise the risk of a joint failure damaging adjacent cables or initiating a fire in the tunnel.
- Consideration shall be given to modified joint kits for any cables using LSOH sheaths, as the standard joint kits may not be suitable.
- Localised fire retardant cable blankets or "wraps" shall be used around Ausgrid HV cables at locations that are exposed (1m -1.5m) to joints in major LV cables. Any derating of Ausgrid cables will need to be assessed and submitted to Ausgrid for approval.

Other issues that are to be considered in the design of shared services tunnels include, but are not limited to, the following:

- Control of shared access in the tunnel
- The FRL requirements of any supporting structure
- Corrosion protection of any supporting structure
- Fire rating of any spray-on fire protective coating used (e.g. Fendolite)
- Future access to conduits/cables
- Responsibility for maintenance of the supporting structure
- Maintenance and ownership of the tunnel.

21. STORES AND MATERIALS

Only approved materials and equipment may be used in the construction of infrastructure which ultimately forms part of Ausgrid's electrical network. The approved materials and equipment contained in this Network Standard are detailed in Ausgrid's Approved Material List (AML) with manufacturer and supplier information and Ausgrid stockcodes where appropriate. Ausgrid will consider adding alternative materials and equipment to the AML in accordance with NS181 - Approval of Materials & Equipment and Network Standard Variations.

ASPs may obtain approved materials and equipment items as listed in the AML from any source. Where an ASP wishes to use alternative materials and equipment, application to have the materials or equipment considered for approval is to be made in accordance with NS181. Alternatively, where approved materials and equipment are held as stock in Ausgrid's stores system, ASPs may purchase them from Ausgrid. All enquiries and requests for quotations shall be directed by email to aspsales@ausgrid.com.au and include the appropriate stockcode numbers.

All materials used on Ausgrid's network must be new.

22. AUTHORITIES AND RESPONSIBILITIES

For this Network Standard the authorities and responsibilities of Ausgrid employees and managers in relation to content, management and document control of this Network Standard can be obtained from the Company Procedure (Network) – Production / Review of Engineering Technical Documents within the document repository. The responsibilities of persons for the design or construction work detailed in this Network Standard are identified throughout this Standard in the context of the requirements to which they apply.

23. RELATED DOCUMENTS

All work covered in this document shall conform to all relevant Legislation, Standards, Codes of Practice and Network Standards. Current Network Standards are available on Ausgrid's Internet site at www.ausgrid.com.au.

ASPs and other persons external to Ausgrid are responsible for sourcing the manufacturer's instructions and manuals.

23.1 Ausgrid documents

- ASP Level 1 Authorisation Agreement
- Company Procedure (Network) – Network Standards Compliance
- Connection Policy
- Contract for Design Related Services
- Electrical Safety Rules
- Electricity Network Safety Management System Manual
- ES1 Premises Connection Requirements
- ES4 Service Provider Authorisation
- Model Standing Offer (MSO) – Standard Connection Services for Contestable ASP/1 Premises Connection no greater than 11kV
- NEG OH14 – Guide to the Assessment of Waterway Crossing Risk
- NS001 Glossary of Terms
- NS100 Field Recording of Network Assets
- NS104 Specification for Electrical Network Project Design Plans
- NS113 Site Selection and Construction Design Requirements for Chamber Substations
- NS117 Design and Construction Standards for Kiosk Type Substations
- NS119 Public Lighting Design and Construction
- NS127 Low Voltage Cable Joints and Terminations
- NS129 11kV Joints and Terminations - Paper Insulated Lead Covered Cables
- NS141 Site Selection and Site Preparation Standards for Kiosk Type Substations
- NS143 Easements, Leases and Rights of Way
- NS156 Working Near or Around Underground Cables
- NS159 Installation of Cables and conduits using Trenchless Techniques
- NS161 Testing of Underground Cables

- NS165 Safety Requirements for Non-Electrical Work in and Around Live Substations
- NS171 Fire Stopping in Substations
- NS172 Design Requirements for Cable Jointing Pits and Vaults
- NS174 Environmental Procedures
- NS177 11kV Joints (including Transition Joints) and Terminations – Polymeric Insulated Cables
- NS181 Approval of Materials and Equipment and Network Standard Variations
- NS181 Approved Material List (AML)
- NS203 Telecommunications Network: Master Policy Document
- NS204 Communications Pits – Specifications and Installation Guidelines
- NS205 Telecommunications: Route Markers
- NS211 Working with Asbestos Products
- NS212 Integrated Support Requirements for Ausgrid Network Assets
- NS224 Low Voltage Suburban Commercial and Industrial Underground Distribution Utilising Pillars
- NS234 Telecommunications Underground Physical Plant Installation
- NS235 Telecommunications Underground to Overhead (UGOH) Transition
- NS272 Cable Rating
- Policy for ASP/1 Premises Connections
- Public Electrical Safety Awareness Plan

23.2 Other standards and documents

- AS1012 Methods of Testing Concrete
- AS1141 Methods for sampling and testing aggregates
- AS1289.5.1.1 Method of testing soils for engineering purposes - Soil compaction and density tests - Determination of the dry density/moisture content relation of a soil using standard compactive effort
- AS1289.5.2.1 Method of testing soils for engineering purposes - Soil compaction and density tests - Determination of the dry density/moisture content relation of a soil using modified compactive effort
- AS1289.5.6.1 Method of testing soils for engineering purposes - Soil compaction and density tests - Compaction control test - Density Index method for a cohesionless material.
- AS1379 Specification and Supply of Concrete
- AS1742 Manual of Uniform Traffic Control Devices
- AS2053.2 Conduits and fittings for electrical installations - Rigid Plain Conduits and Fittings of Insulating Material
- AS2758.1 Aggregates and Rock for Engineering Purposes – Concrete Aggregates
- AS3600 Concrete Structures
- AS3610 Formwork for Concrete

- AS3972 General purpose and Blended Cements
- AS4130 Polyethylene (PE) Pipes for Pressure Applications
- AS4671 Steel for the Reinforcement of Concrete
- AS6947 Crossing of Waterways by Electricity Infrastructure
- ENA Doc 001-2008 National Electricity Network Safety Code
- Memorandum of Understanding Between Ausgrid & Roads And Maritime Services & Transport For NSW
- NATSPEC1152 – Road Openings and Restorations (Utilities)
- New South Wales Specification (AUS-SPEC#2, 306U) – Road Openings and Restorations
- NSW Streets Opening Coordination Council (SOCC) Guide to Codes and Practices for Streets Opening
- Specification M209 Road Openings and Restoration
- Specification 3051 – Granular Base and Subbase Materials for Surfaced Road Pavements
- Underground Services in a Shared Trench (NSW 1998) agreement between AGL, EnergyAustralia, Optus and Telstra
- SafeWork NSW Excavation Work Code of Practice 2020
- SafeWork NSW Work Near Underground Assets - Guide

23.3 Acts and regulations

- Electricity Supply (General) Regulation 2014 (NSW)
- Electricity Supply (Safety and Network Management) Regulation 2014 (NSW)
- Protection of the Environment Operations Act 1997
- Protection of the Environment Operations (Waste) Regulation 2014 (NSW)
- Roads Act 1993
- The Coal Ash Order 2014
- The Coal Ash Exemption 2014
- Work Health and Safety Act 2011 (NSW)
- Work Health and Safety Regulation 2017 (NSW)

24. DEFINITIONS

Refer to NS001 Glossary of Terms.

25. RECORDKEEPING

The table below identifies the types of records relating to the process, their storage location and retention period.

Table 12 – Recordkeeping

Type of Record	Storage Location	Retention Period*
Approved copy of the Network Standard	Document repository Network sub process Standard – Company	Unlimited
Draft Copies of the Network Standard during amendment/creation	Work Folder for Network Standards (HPRM ref. 2014/21250/292)	Unlimited
Working documents (emails, memos, impact assessment reports, etc.)	Records management system Work Folder for Network Standards (HPRM ref. 2014/21250/292)	Unlimited

* The following retention periods are subject to change e.g. if the records are required for legal matters or legislative changes. Before disposal, retention periods should be checked and approved by the Records Manager.

26. DOCUMENT CONTROL

Content Coordinator : Head of Asset Engineering Policy & Standards

Distribution Coordinator : Manager Asset Standards

Annexure A – List of Drawings

IMPORTANT: Users must ensure that the drawings they are using are the current versions with all amendments.

Table A1- Drawings List

Number	Title
212386_1	Telecommunications External Plant Optical Fibre Construction Drawing Index
212386_2	Telecommunications External Plant Optical Fibre Construction OPGW with Subtransmission UGOH
212386_3	Telecommunications External Plant Optical Fibre Construction ADSS UGOH
212386_4	Telecommunications External Plant Optical Fibre Construction OPGW UGOH
212386_5	Telecommunications External Plant Optical Fibre Construction ADSS Termination with 11kV UGOH
212393_1	Ausgrid Fibre Network Fibre & Duct Arrangement Index Page
212393_2	Ausgrid Fibre Network Fibre Duct Arrangement Typical Size 8 Communications Jointing Pit
212393_3	Ausgrid Fibre Network Fibre Duct Arrangement Typical Pit Construction Load Classification Class C & Class D
212393_4	Ausgrid Fibre Network Fibre & Duct Arrangement Typical Communications Conduit Breakout Detail For Each Side of Route for Dual Circuit
212393_5	Ausgrid Fibre Network Fibre & Duct Arrangement Breakout Detail on Same Side of Route for Dual Circuit Arrangement A
212393_6	Ausgrid Fibre Network Fibre & Duct Arrangement Breakout Detail on Same Side of Route for Dual Circuit Arrangement B
212393_7	Ausgrid Fibre Network Fibre & Duct Arrangement Distributed Temperature Sensing (DTS) Typical Breakout Arrangement A
212393_8	Ausgrid Fibre Network Fibre & Duct Arrangement Distributed Temperature Sensing (DTS) Typical Breakout Arrangement B
212393_9	Ausgrid Fibre Network Fibre & Duct Arrangement Combined DTS & Comms Typical Breakout Arrangement A
212393_10	Ausgrid Fibre Network Fibre & Duct Arrangement Combined DTS & Comms Typical Breakout Arrangement B
212393_11	Ausgrid Fibre Network Fibre & Duct Arrangement Combined DTS & Comms Typical Lay Flat Arrangement Breakout Details
212393_12	Ausgrid Fibre Network Fibre & Duct Arrangement Combined DTS & Comms Typical Breakout To Bypass HV Jointing Pit (Single Circuit)
212393_13	Ausgrid Fibre Network Fibre & Duct Arrangement Combined DTS & Comms Typical Breakout - DTS Entering HV Jointing Pit (Single Circuit)
212393_14	Ausgrid Fibre Network Fibre & Duct Arrangement Combined DTS & Comms Typical Breakout To Bypass HV Jointing Pit (Double Circuit)
212393_15	Ausgrid Fibre Network Fibre & Duct Arrangement Combined DTS & Comms Typical Breakout - DTS Entering HV Jointing Pit (Double Circuit)
212393_16	Ausgrid Fibre Network Fibre & Duct Arrangement Fibre Cable Flow Through Typical Communications Pit
212393_17	Ausgrid Fibre Network Fibre & Duct Arrangement Combined DTS & Comms Typical Breakout 2 x 2 HV Conduit Arrangement

Number	Title
212393_18	Ausgrid Fibre Network Fibre & Duct Arrangement Inline Fibre Hauling Pit Typical Arrangement
212393_19	Ausgrid Fibre Network Fibre & Duct Arrangement In Road Comms Pit
514020	Lighting Column Concrete Plinth Steel Mould (For Use With Ragbolt Assembly)
514087	Standard Construction Street Lighting Column Pile Footing Details
49070	Cable Installations Polythene Warning Strip Details
249060	Cable Pit (Precast) Typical Indicative Details

Annexure B – Typical Trench Dimensions

Refer to Clause 10.11 for standard depth of cover.

Table B1: Conduit Trench Dimensions (125mm)

Number of Conduits (125mm PVC)	Classified Roadway Trench		Unclassified Regional and Local Roadway Trench		
	Width(mm)	Depth(mm)		Width(mm)	Depth(mm)
		Conduits protected	Conduits unprotected		
1 or 2	430	1190	1390	430	940
3	620	1190	1390	620	940
4 (2 on 2)	430	1380	1580	430	1130
6 (3 on 3)	620	1380	1580	620	1130

OD of 125mm PVC conduit is approx. 140mm

Table B2: Conduit Trench Dimensions (150mm)

Number of Conduits (150mm PVC)	Classified Roadway Trench		Unclassified Regional and Local Roadway Trench		
	Width(mm)	Depth(mm)		Width(mm)	Depth(mm)
		Conduits protected	Conduits unprotected		
1 or 2	530	1230	1430	530	980
3	760	1230	1430	760	980
4 (2 on 2)	530	1460	1660	530	1210
6 (3 on 3)	760	1460	1660	760	1210

OD of 150mm PVC conduit is approx. 160mm.

Note: “Protected” refers to concrete or TSB to achieve a compressive strength of 3 to 5 MPa.
 “Unprotected” refers to 20:1 sand/cement dry mix.

Annexure C – Typical Cable Arrangements in Footways

HV and LV Cables Laid Direct

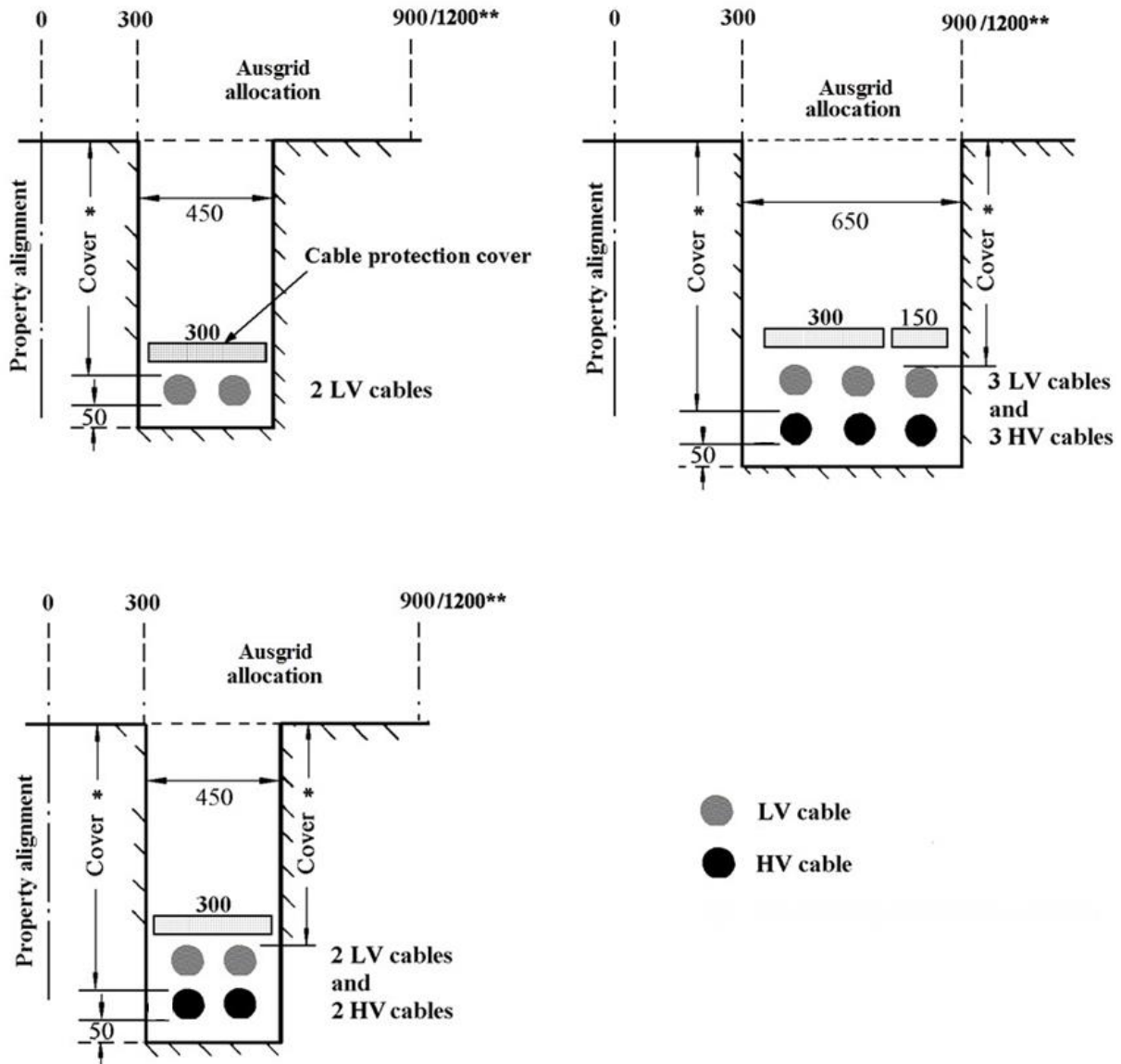

Figure C1

Cover* 500mm (minimum) over LV cables
 600mm (minimum) over HV cables
 600mm (minimum) over protection fibre conduits installed alongside a HV feeder cable / conduit
 900mm (minimum) over protection fibre conduits straying away from a HV feeder conduit / cable to enter a communications pit.

** Width of Ausgrid allocation depends on the date of roadway dedication. Refer to Annexure D for further details.

Note: Refer to Clause 10.10 for standard spacings.

HV and LV cables laid direct (with spare conduits)

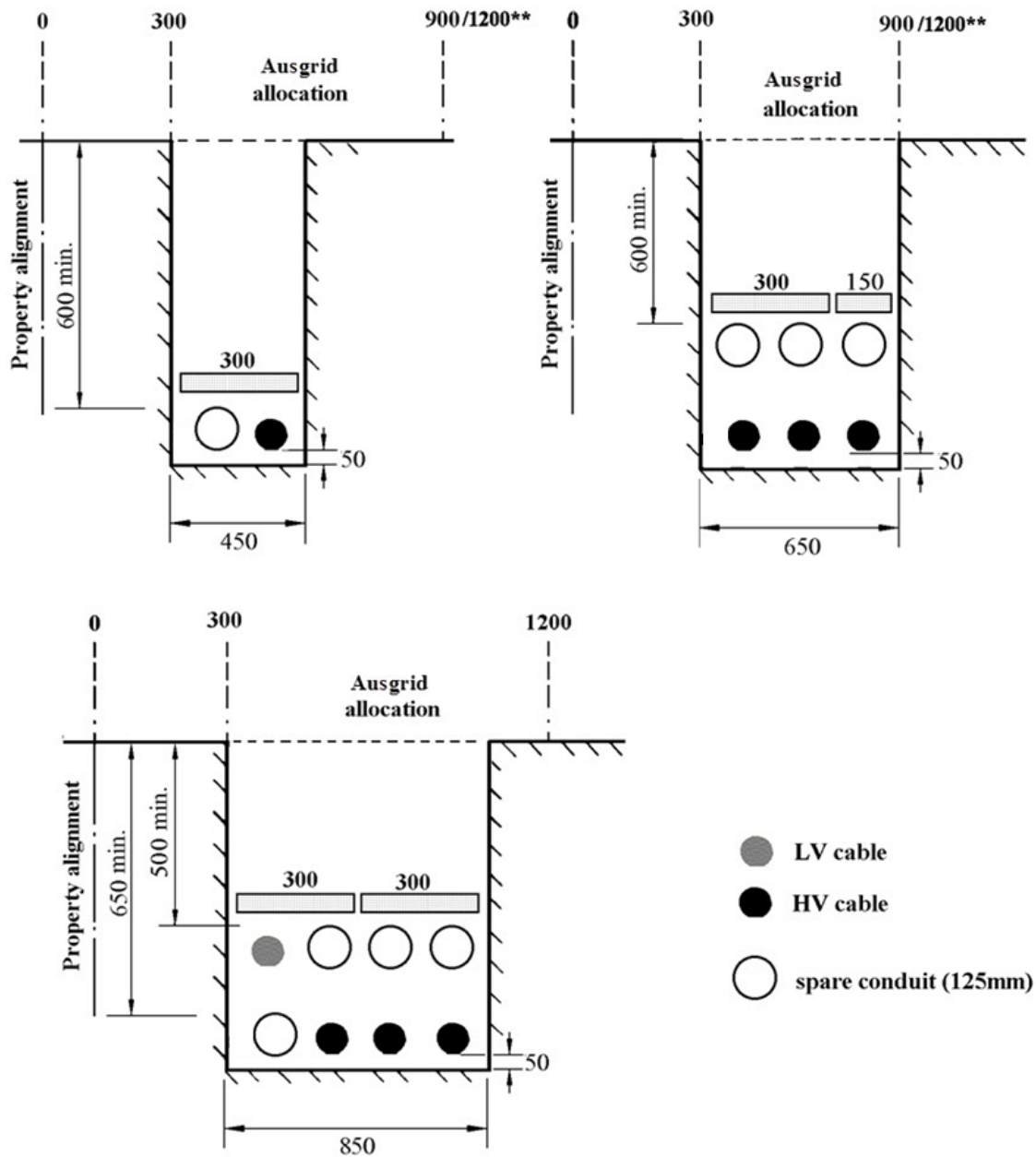
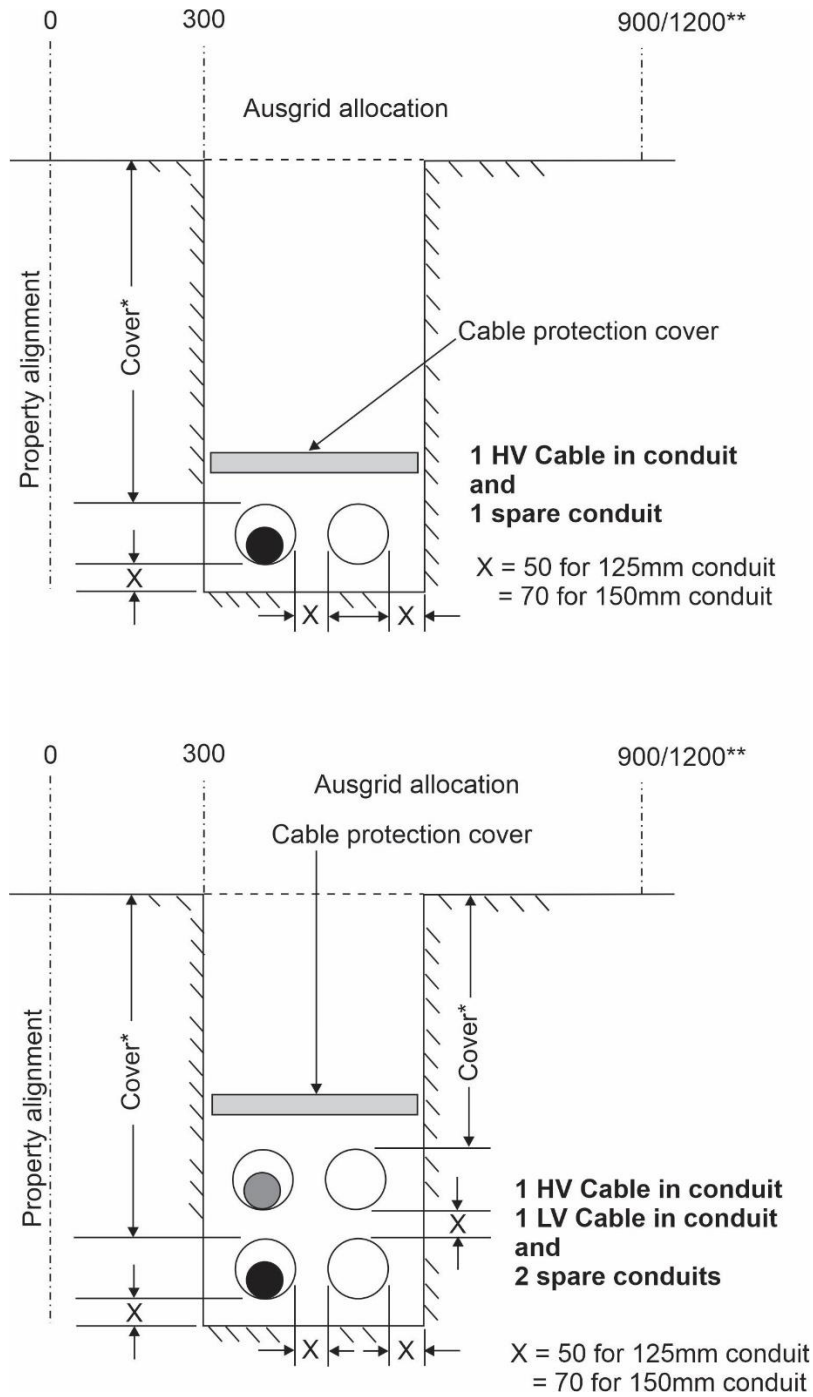

Figure C2

** Width of Ausgrid allocation depends on the date of roadway dedication. Refer to Annexure D for further details.

Note: Refer to Clause 10.10 for standard spacings.

HV and LV cables laid in conduits



Cover* 500mm (minimum) over LV cables
 600mm (minimum) over HV cables

** Width of Ausgrid allocation depends on the date of roadway dedication. Refer to Annexure D for further details.

Figure C3

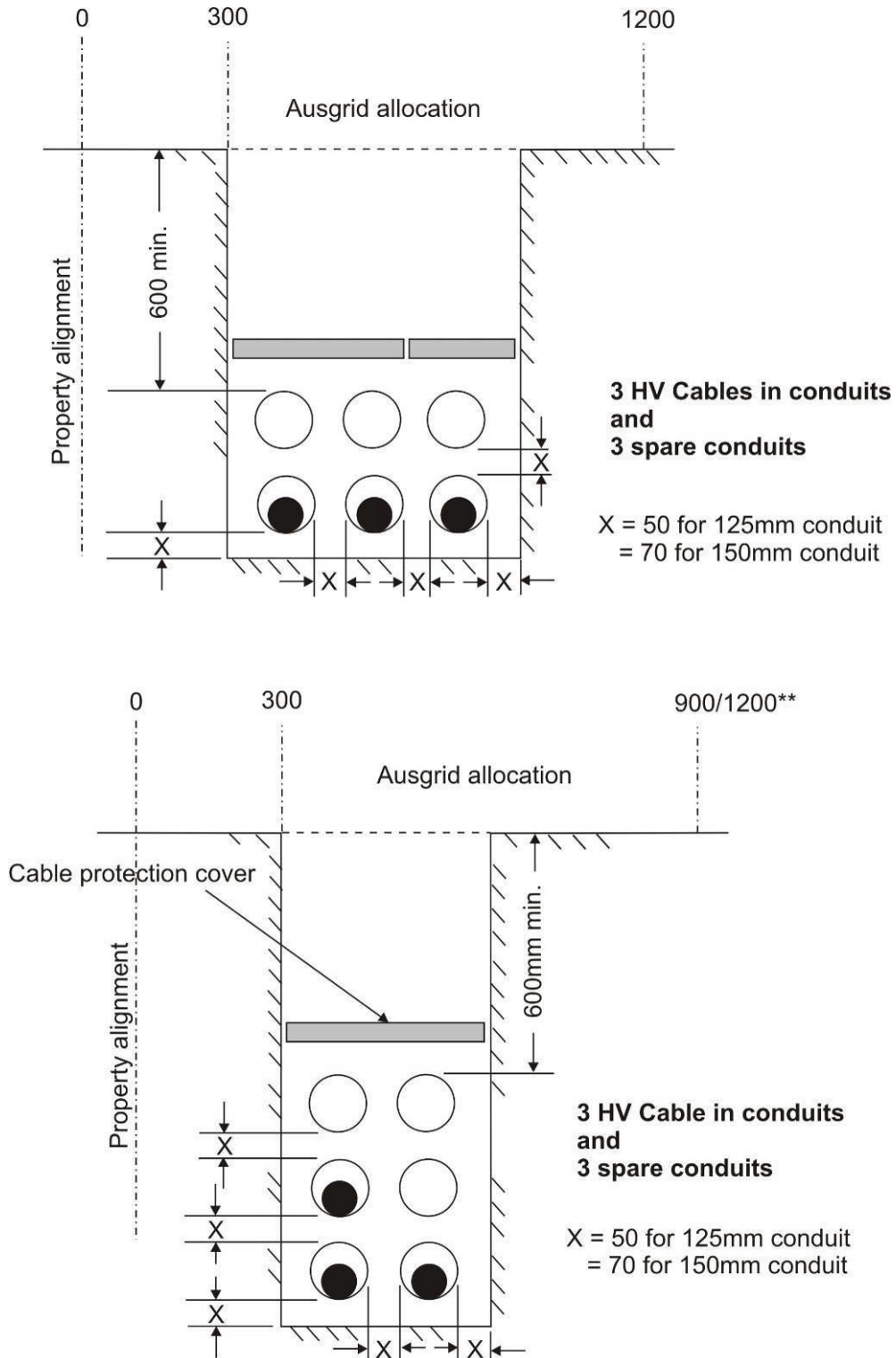

** Width of Ausgrid allocation depends on the date of roadway dedication. Refer to Annexure D for further details.

Figure C4

Trenches shared with Telecommunications Carriers (default shared trench agreement)

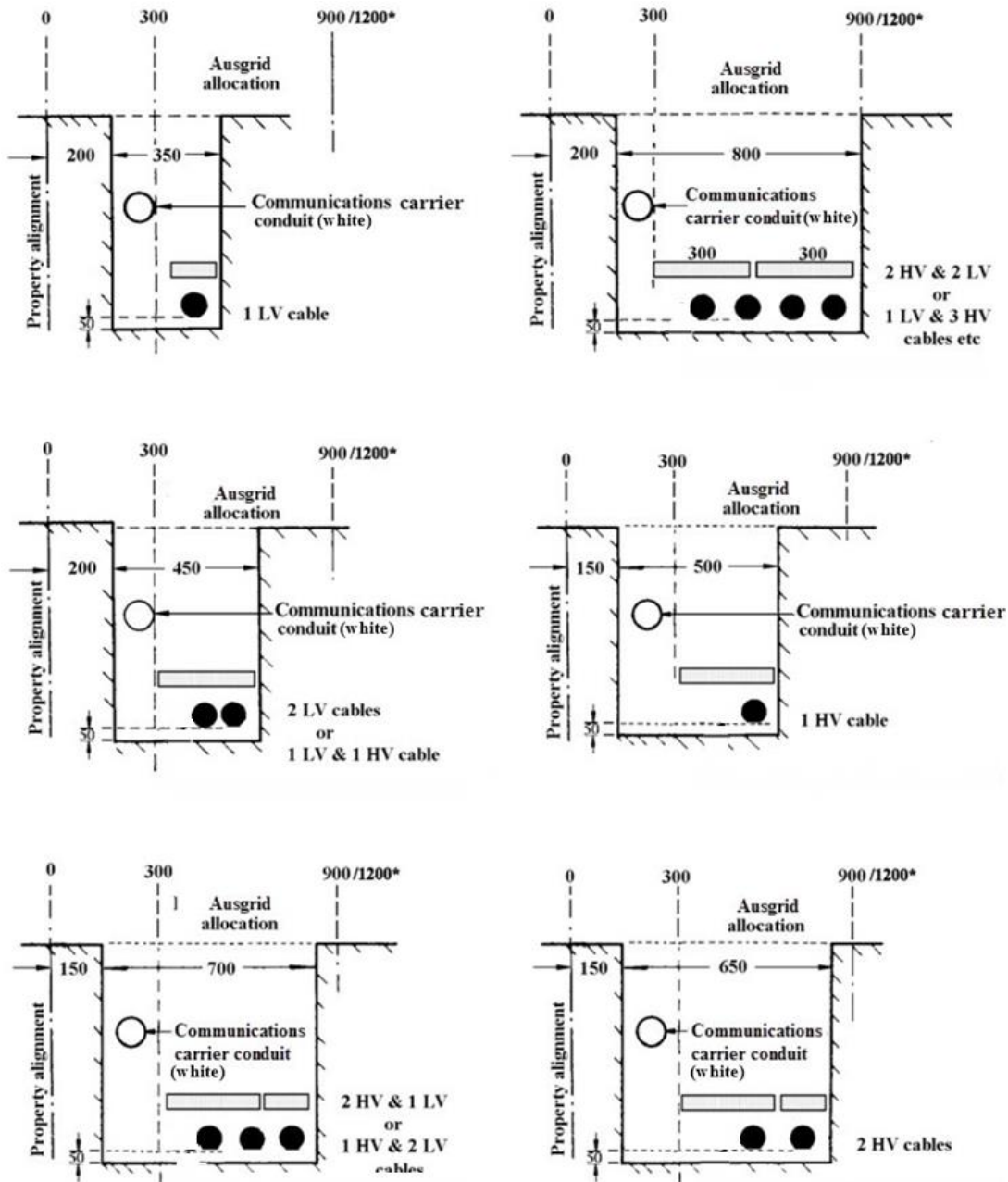

Figure C5

* Width of Ausgrid allocation depends on the date of roadway dedication. Refer to Annexure D for further details.

All trenches shall be 750mm deep. Refer to Clause 10.10 for standard spacings.

Minimum vertical separation between communications carrier and cable protection covers:

- 150mm above cable protection covers over low voltage cables or conduits
- 300mm above cable protection covers over high voltage cables or conduits

Annexure D – Footway Allocations

For footway allocations, refer to NSW Streets Opening Coordination Council (SOCC) - Guide to Codes and Practices for Streets Opening 2018 edition.

For Regional footway allocations prior to 2018, refer to NSW Streets Opening Conference - Guide to Codes and Practices for Streets Opening 2009 edition.

For footway allocations in Sydney Region prior to 1991, refer to Figure D1.

For streets outside city boundary

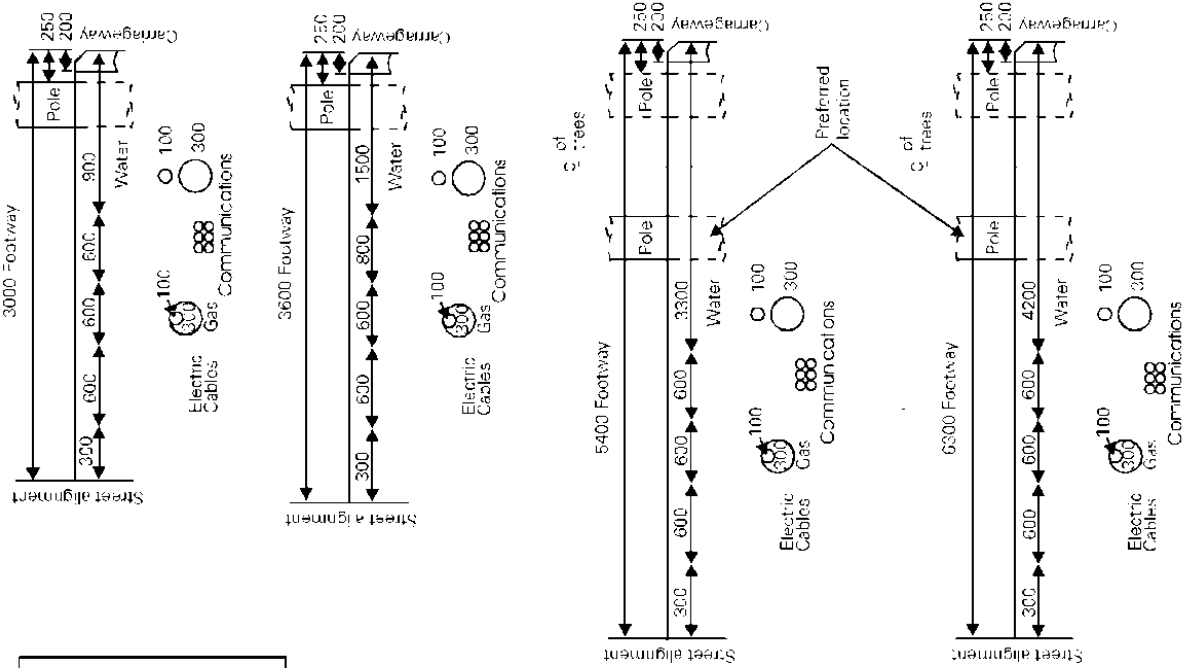

STREETS OPENING CONFERENCE
PUBLIC UTILITY MAINS
 Allocation of space on 3m, 3.6m, 5.4m, and 6.3m footways

For streets within city boundary

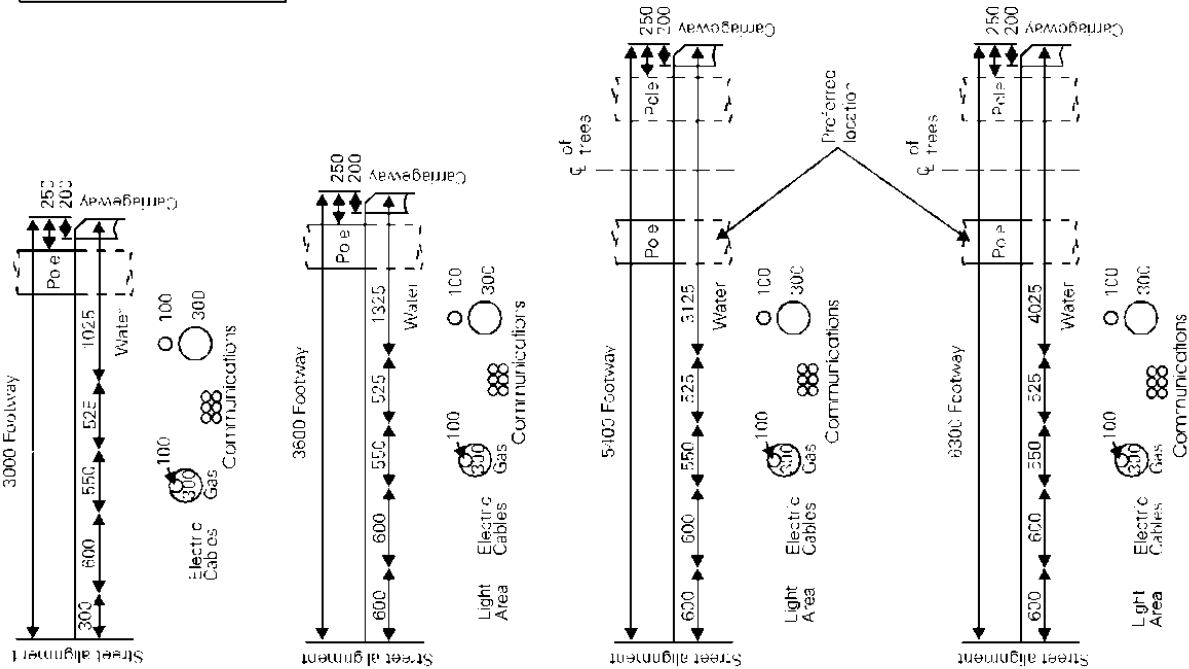

Figure D1 - Existing Footway Areas before 1.1.91 - Sydney Region

Annexure E – Guide to Maximum Pulling Tensions

E1 Using stocking grips

For the conventional methods of installation using a stocking grip and pulling on the “nose” of the cable only, the maximum allowable pulling tension is mainly a function of cable diameter. The limiting factors are related to compressibility of the sheath, bedding and insulation, and to the friction between these, rather than to the tensile strength of conductors or the cable as a whole. The table below provides a guide only to maximum pulling tensions.

The contractor shall obtain the manufacturer’s recommended maximum pulling tension before applying any mechanical load to the cables. Annexure F is guide to calculating the winching tension required to pull a cable through a trench or conduit bank route of predetermined geometry.

Table E1: Maximum Pulling Tensions when using Stocking Grips

Type of Cable**	*Max. Pull Tension (kN**)	Approximate Cable Mass (kg/m)
11kV Unarmoured Power Cables		
500 CU3 TRXQ 35 CU(WS) Z YQ	11.1	17.9
500 AL3 TRXQ 35 CU(WS) Z YQ	11.0	8.5
500 AL3 P H L YQ	19.2	13.2
400 AL3 TRXQ 35 CU(WS) Z YQ	10.5	7.3
300 AL3 TRXQ 35 CU(WS) Z YQ	9.5	6.2
300 CU3 P H L YQ	13.6	15.0
300 AL3 P H L YQ	13.6	9.3
240 AL3 P H L YQ	11.6	8.1
185 AL3 TRXQ 35 CU(WS) Z YQ	8.2	4.6
185 CU1 TRXQ 70 CU(WS) Z YQ	3.8	2.9
150 CU3 TRXQ 35 CU(WS) Z YQ	7.7	6.8
95 AL3 TRXQ 16 CU(WS) Z YQ	6.6	2.8
630 CU1 TRXQ 120 CU(WS) Z YQ	6.0	7.8
300 CU1 TRXQ 150 CU(WS) Z YQ	4.8	4.8
300 CU1 P H L Z	4.4	5.2
300 CU1 TRXQ 70 CU(WS) Z YQ	4.6	4.1
300 CU1 TRXQ 70 CU(WS) Z YQ/Triplex	13.8 (for total cable, 1 stocking required) 4.6 (for each core, 3 stockings required)	12.4
185 CU1 P H L Z	3.2	3.5
185 CU1 TRXQ CU(WS) Z YQ / Triplex	12.6 (for total cable, 1 stocking required) 4.2 (for each core, 3 stockings required)	8.9
70 CU1 G TRXQ G 16 CU(WS) YQ	2.2	1.1
35 AL1 G TRXQ G 16 CU(WS) YQ	1.7	0.5
LV Unarmoured Power Cables		
300 AL4 XQ Z/SAC	7.0	4.42
240 CU4 XQ Z	6.8	9.81
240 AL4 XQ Z/SAC	6.1	3.9
120 AL4 XQ Z/SAC	4.5	1.8
500 CU1 XQ Z	4.5	4.93
300 CU1 XQ Z	3.1	3.1
185 CU1 XQ Z	1.8	1.9
LV Service and Street Lighting Cables		
16 CU2 XQ Z	N/A	0.47
16 CU4 XQ Z	N/A	0.9

Type of Cable**	*Max. Pull Tension (kN**)	Approximate Cable Mass (kg/m)
25 CU4 XQ Z	N/A	1.3
50 CU4 XQ Z	N/A	2.2

* Using stocking grips.

** 1 tonne = 10kN (approx.)

N/A Not applicable, cable to be installed by hand.

*** When pulling multiple single core cables together, the maximum pulling tension is the maximum pulling tension of one single core cable multiplied by the number of cables.

E2 Using pulling eyes

Pulling eyes allow for much larger pulling tensions than stocking grips. A guide to the maximum pulling tension that can be applied to a cable while using pulling eyes is provided in the table below.

Table E2: Maximum Safe Tensile Stress when using Pulling Eyes fitted to the Conductor

Conductor Material	Maximum Tension kN/mm ²
Copper	0.07
Stranded aluminium	0.05
Solid aluminium	0.03

Note: Maximum pulling tension is limited to 20kN. Please consult the cable manufacturer for advice if higher pulling tensions are required.

Where a pulling eye is considered necessary, the cable supplier shall be contacted for either fitting the pulling eye to the cable or providing details of approved pulling eyes.

Before pulling a cable with a pulling eye, the installer shall ascertain from the cable supplier what maximum sidewall pressure can be applied to the cable and shall ensure that this sidewall pressure is not exceeded during cable installation.

Cable ends fitted with pulling eyes shall be waterproofed to ensure water does not enter the cables during installation, regardless of the type of pulling eyes fitted. Waterproofing can be achieved by shrinking a length of mastic lined heatshrink sleeve, covering the full length of the pulling eye and overlapping the cable sheath by at least 150mm. Before installing heatshrink sleeves, the pulling eyes and associated cable ends shall be thoroughly degreased and cleaned. The heatshrink sleeves used shall be abrasion resistant and shall have a minimum wall thickness of 3mm after recovery over the pulling eye.

Particular care must be exercised when pulling at the relatively high tensions allowed by the use of pulling eyes. Large bending radii and adequate support using rollers must be provided to avoid causing flattening, distortion or other damage to the cables.

Pulling cables into conduits

Prior to pulling cables through Asbestos Cement conduits refer to the appropriate Safe Work Method Statement.

The pulling tension on cables being pulled into conduits shall not exceed 20kN, including cables fitted with pulling eyes. Please consult the cable manufacturer for advice if higher pulling tensions are required.

In addition, the maximum sidewall pressure exerted onto a cable must not exceed the following values when the conduit is installed in compacted standard bedding or 20:1 sand cement bedding:

- 3kN/m for a 'rough bore' conduit, e.g. fibre reinforced cement
- 5kN/m for a 'smooth bore' conduit, e.g. plastic conduits.

For UPVC conduits installed in TSB, dry mix or concrete encased the maximum sidewall bearing pressure exerted on the cable must not exceed the value specified by the cable manufacturer. At least 7 days is required for sufficient strength gain of the encasement around the conduits.

E3 Using Cable Pulling Lubricants

Approved cable pulling lubricants are used to lower the friction between the cable sheath and the conduit wall which reduces the cable pulling tension during the cable installation.

If the design requires the use of cable pulling lubricants, the Designer shall specify on their design plan the:

- coefficient of friction used in the calculated cable pulling tensions (refer to Clause 4.9).
- approved lubricant (product name/code) to be used.
- volume of lubricant required to achieve the desired coefficient of friction.

Ausgrid's Approved Material List (AML) provides a list of suppliers of cable pulling lubricants and their product names/codes.

The installer needs to apply the approved cable pulling lubricant strictly in accordance with the manufacturer's instructions to achieve the coefficient of friction specified on the Certified Design/Design Plan.

Annexure F – Guide to Calculating Cable Pulling Tension

F1 Equations for Calculating Cable Pulling Tensions

The following guide is extracted from Annexure A of publication C(b)2 – 1989 ESAA Guide to the Installation of Cables Underground.

APPENDIX A

CABLE PULLING TENSION

The winching tension required to pull a cable through a trench or ductline route of predetermined geometry can be calculated by using the formulae given below.

Complex route geometries must first be subdivided into simple sections, each identifiable with one of the basic shapes illustrated.

The formula accompanying each illustrated shape gives a determination of the tension (T) imposed upon the leading end of a cable as it exits from the section when the tension (T_0) at the commencement of that section is known.

SYMBOLS USED

- T_0 = Tension at the commencement of a section [N]
- T = Tension at the end of a section [N]
- M = Mass of cable per unit length [kg m^{-1}]
- W = Equivalent cable force per unit length = $9.81 M$ [N m^{-1}]
- μ = Coefficient of friction in a given section
- L = Length of a straight level section [m]
or length of an inclined section [m]
- R = Radius of a horizontal bend [m]
- θ = Angle of a subtended arc in a bend [rad]
or angle of an incline to the horizontal [rad]
- F = Side wall force [N m^{-1}]

(1) STRAIGHT LEVEL SECTION

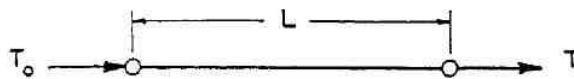

$$T = T_0 + \mu WL$$

(2) UPWARD INCLINE

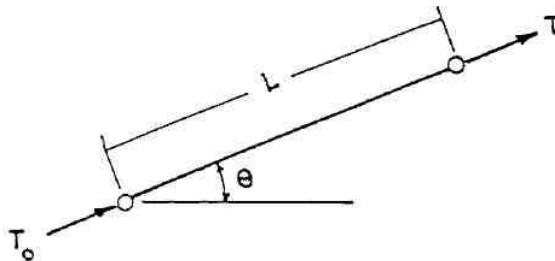

$$T = T_0 + WL (\sin \theta + \mu \cos \theta)$$

(3) DOWNWARD INCLINE

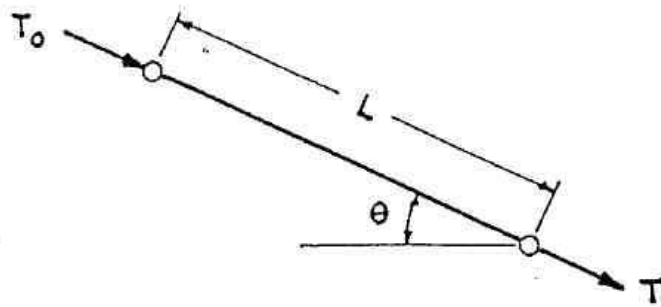

$$T = T_0 - WL (\sin \theta - \mu \cos \theta)$$

(4) HORIZONTAL BEND

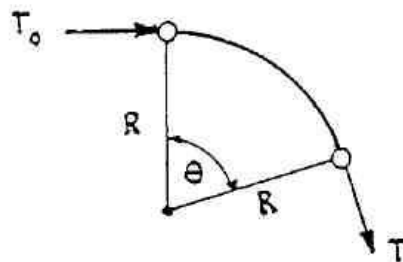

$$T = T_0 \cosh (\mu \theta) + \sqrt{(T_0)^2 + (WR)^2} \sinh (\mu \theta)$$

(5) UPWARD CONVEX BEND

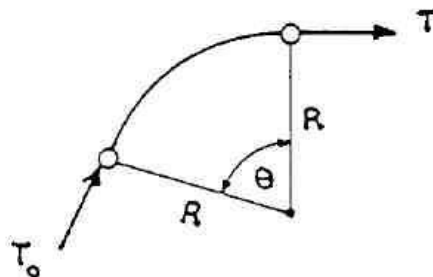

$$T = T_0 e^{\mu \theta} + \frac{WR}{1 + \mu^2} [2\mu e^{\mu \theta} \sin \theta + (1 - \mu^2) (1 - e^{-\mu \theta} \cos \theta)]$$

(6) DOWNWARD CONVEX BEND

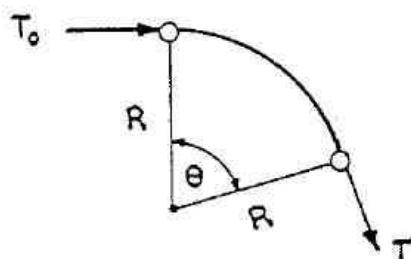

$$T = T_0 e^{\mu \theta} + \frac{WR}{1 + \mu^2} [2\mu \sin \theta - (1 - \mu^2) (e^{\mu \theta} - \cos \theta)]$$

(7) UPWARD CONCAVE BEND

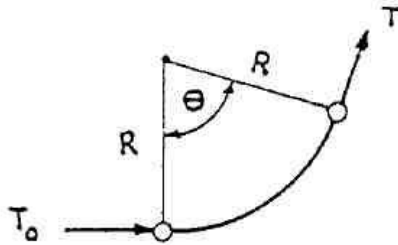

$$T = T_0 e^{\mu\theta} - \frac{WR}{1 + \mu^2} [2\mu \sin \theta - (1 - \mu^2) (e^{\mu\theta} - \cos \theta)]$$

(8) DOWNWARD CONCAVE BEND

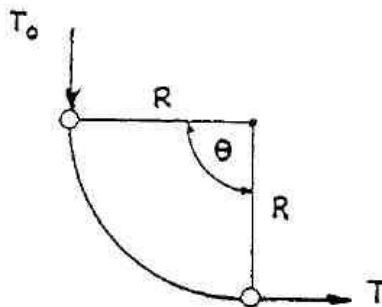

$$T = T_0 e^{\mu\theta} - \frac{WR}{1 + \mu^2} [2\mu e^{\mu\theta} \sin \theta + (1 - \mu^2) (1 - e^{\mu\theta} \cos \theta)]$$

NOTE For any horizontal, convex or concave bend tension (T) can be reasonably determined by the approximate expression;

$$T = T_0 e^{\mu\theta}$$

(9) OFFSET BENDS

The formulae given in (5), (6), (7) and (8) for convex and concave bends are only valid when θ is measured from a vertical axis.

If angle θ is offset from a vertical axis by some angle ϕ tension (T) can be calculated by the method illustrated below for an upward convex bend.

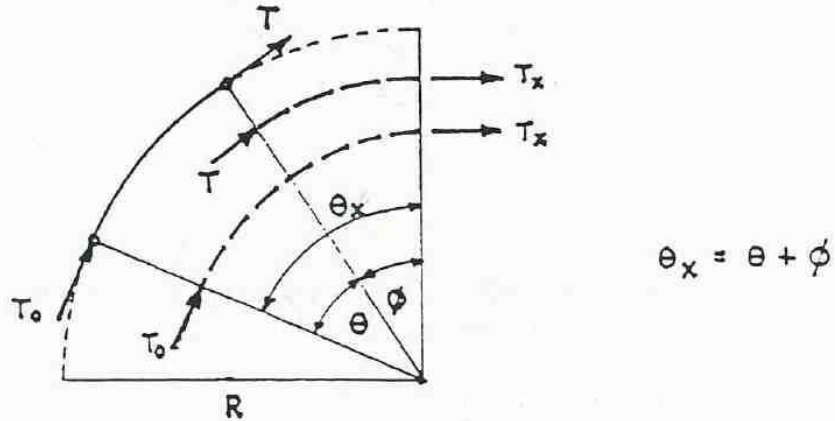

$$T_x = T_0 e^{\mu \theta x} + \frac{WR}{1 + \mu^2} [2\mu e^{\mu \theta x} \sin \theta_x + (1 - \mu^2) (1 - e^{\mu \theta x} \cos \theta_x)]$$

$$T = \frac{T_x - \frac{WR}{1 + \mu^2} [2\mu e^{\mu \phi} \sin \phi + (1 - \mu^2) (1 - e^{\mu \phi} \cos \phi)]}{e^{\mu \phi}}$$

(10) SIDE WALL FORCE

When pulling cables around bends, the side wall force is sometimes the limiting factor. The side wall force is determined from the formula:-

$$F = \frac{T}{R}$$

The maximum allowable side wall force is nominated by the cable manufacturer.

REFERENCE Electric Power Research Institute "Maximum Safe Pulling Lengths for Solid Dielectric Insulated Cables, Volume 2: Cable Users Guide", Report EL-3333-CCM, Volume 2, Research Project 1519-1, February, 1984.

F2 Coefficient of Friction – Dry Values

The following dry value coefficients of friction (COF) are extracted from EPRI Report EL-3333.

Table F1: Coefficients of Friction (Dry Values, no Lubricant Applied)

Conduit Material	Cable Outer Covering	Coefficient of Friction
UPVC	XLPE	0.40
	PE (Polythene)	0.40
	PVC	0.50
	HDPE	0.50
	Neoprene	0.90
	Lead	0.25
PE	XLPE	0.30
	PE	0.25
	PVC	0.40
	Neoprene	0.40
	Lead	0.25
Fibre (German Duct)	XLPE	0.30
	PE	0.25
	PVC	0.40
	Neoprene	0.40
Concrete	XLPE	0.30
	PE (Polythene)	0.35
	PVC	0.55
	Neoprene	0.50
	Lead	0.55
Fibre Cement	XLPE	0.70
	PE	0.70
	PVC	0.70
	Neoprene	1.00
Steel	XLPE	0.60
	PE	0.50
	PVC	0.65
	Neoprene	1.05

F3 Coefficient of Friction with Cable Pulling Lubricants

Lower values of COF may be used in the cable pulling calculations if approved cable pulling lubricants are specified. The actual value of COF will depend on the type of cable pulling lubricant, the quantity used, the application method and the cable sheath and conduit materials. Apply a safety factor of 50% to the manufacturer's recommended COF value to account for site conditions, before using the COF value in the cable pulling calculations, i.e. COF for Cable Pulling Calculation = 1.5 x Manufacturer's Recommended COF.

Annexure G – Stockcodes of Approved Items

Table G1: Approved Item Stockcodes

Item	Stockcode
Cables:	
11kV 500 AL3 TRXQ 35 CU(WS) Z YQ	178947
11kV 500 CU3 TRXQ 35 CU(WS) Z YQ	178813
11kV 300 CU1 TRXQ 70 CU(WS) Z YQ	177995
11kV 300 CU1 TRXQ 70 CU(WS) Z YQ/Triplex	179122
11kV 400 AL3 TRXQ 35 CU(WS) Z YQ	177562
11kV 300 AL3 TRXQ 35 CU(WS) Z YQ	177561
11kV 185 AL3 TRXQ 35 CU(WS) Z YQ	177566
11kV 150 CU3 TRXQ 35 CU(WS) Z YQ	177565
11kV 95 AL3 TRXQ 16 CU(WS) Z YQ	177564
11kV 630 CU1 TRXQ 120 CU(WS) Z YQ	90050
11kV 1000 CU1 TRXQ 120 CU(WS) Z YQ	177203
11kV 185 CU1 TRXQ 70 CU(WS) Z YQ/Triplex	181758
11kV 70 CU1 TRXQ 16 CU(WS) YQ	177568
11kV 35 AL1 TRXQ 16 CU(WS) YQ	67140
11kV 185 CU1 TRXQ 70 CU(WS) Z YQ	182311
11kV 300 CU1 TRXQ 150 CU(WS) Z YQ	177304
11kV 300 CU3 P H L YQ	1396
11kV 300 CU1 TRXQ 70 CU(WS) YQ LSZH/Triplex	182474
Pilot cable 4-core Nylon Translay 1.5CU4QQZNY/TR WHITE	78683
Pilot cable 4-core Nylon Translay 1.5CU4QQZNY/TR BLACK	78717
Pilot cable 4-core Nylon Translay 1.5CU4QQZNY/TR BLUE	78766
Pilot cable 4-core Nylon Translay 1.5CU4QQZNY/TR RED	78782
415V 300 AL4 XQ Z/SAC	185413
415V 240 AL4 XQ Z/SAC	141739
415V 240 CU4 XQ Z	H108589**
415 500 CU1 XQ Z	14258
415V 300 CU1 XQ Z	14266
415V 185 CU1 XQ Z / COM / 4 CABLES (Parrot cable, is not UV stable and not suitable for outdoor use i.e. UGOH)	151183
415V 185 CU1 XQ Z	61432
240V 16 CU2 XQ Z	174565
415V 16 CU4 XQ Z	148668
415V 50 CU4 XQ Z	149112
** To be used only when the design specifies	
UPVC Conduits to AS/NZS 2053.2:	
50mm nominal diameter, 4m long, heavy duty rigid UPVC orange conduit	78022
63mm nominal diameter, 4m long, heavy duty rigid UPVC orange conduit	181361
100mm nominal diameter, 3m long, light duty rigid UPVC orange conduit	78154
125mm nominal diameter, 3m long, light duty rigid UPVC orange conduit	78188

125mm nominal diameter, 6m long, light duty rigid UPVC orange conduit				78162
150mm nominal diameter, 6m long, light duty rigid UPVC orange conduit				78147
150mm nominal diameter, 3m long, light duty rigid UPVC orange conduit				182376
Item				Stockcode
UPVC Conduits to AS/NZS 2053.2 and AS/NZS 1477:				
200mm nominal diameter, 6m long, light duty rigid UPVC orange conduit				178771
Heavy Duty Rigid UPVC Orange Bends to AS/NZS 2053.2				
Conduit Dia (mm)	Radius 'R' (m)	Angle (degrees)	Nominal Bend Length from coupling to coupling 'L' (mm)	Stockcode
50	1.2	45	1120	179832
50	1.2	90	2060	179941
50	0.3	22.5	255	181756
50	0.3	45	350	181755
50	0.3	11.25	205	181757
63	6	30	3400	181388
63	6	15	1800	181389
63	1.2	45	1050	182446
63	1.2	90	2000	182448
63	1.2	22.5	580	182445
Light Duty Rigid UPVC Orange Bends to AS/NZS 2053.2:				
Conduit Dia (mm)	Radius 'R' (m)	Angle (degrees)	Nominal Bend Length from coupling to coupling 'L' (mm)	Stockcode
100	0.6	90	1300	77602
100	1	11.25	450	77461
100	1	22.5	700	77487
100	1	90	1950	H8503
125	1	11.25	550	77503
125	1	22.5	800	77529
125	1	90	2000	77610
125	1.8	6	550	77578
125	1.8	11.25	750	77586
125	1.8	22.5	1100	77545
125	1.8	45	1850	77552
125	1.8	90	3400	177101
125	2.3	6	600	177856
125	2.3	11.25	900	177857
125	2.3	22.5	1300	177858
125	2.3	45	2200	177859
125	2.3	90	4050	177860
150	2.5	6	650	179064
150	2.5	22.5	1400	179065
150	2.5	45	2420	179066
150	6	15	2100	178791
150	6	30	3600	181387
150	10	11.25	2100	77560

Item				Stockcode
Light Duty Rigid UPVC Orange Bends to AS/NZS 2053.2 and AS/NZS 1477:				
Conduit Dia (mm)	Radius 'R' (m)	Angle (degrees)	Nominal Bend Length from coupling to coupling 'L' (mm)	Stockcode
200	6	15	2100	178772
200	6	22.5	3100	181754
UPVC Couplings to AS/NZS 2053.2:				
50mm, light duty rigid UPVC orange coupling				179831
63mm, heavy duty rigid UPVC orange coupling				185461
100mm, light duty rigid UPVC orange coupling				H9703
125mm, light duty rigid UPVC orange coupling				179192
150mm, light duty rigid UPVC orange coupling				179191
UPVC Couplings to AS/NZS 2053.2 and AS/NZS 1477:				
200mm, light duty rigid UPVC orange coupling				179194
Conduit Reducers:				
150mm to 125mm conduit reducer, medium duty PVC white				176823
180mm to 150mm conduit reducer, UPVC Orange				180482
Heavy Duty Bellmouths:				
50mm				180004
100mm				180003
125mm				180002
150mm				180001
63mm				182449
Miscellaneous:				
Plug for 50mm heavy duty rigid conduit				179754
Plug for 125mm and 150mm light duty rigid conduit (<i>flower pot</i>)				77750
Plug for 150mm light duty rigid conduit				H85126
Plug for 63mm heavy duty rigid conduit				182450
PVC solvent cement				38463
Conduit sealing putty				75481
Conduit sealing foam kit				180112
Polymeric Cable Protection Covers, Steel Plates and Warning Tape:				
150mm x 1.2m slabs polymeric cable cover				151100
300mm x 1.2m slabs polymeric cable cover				151076
150mm x 20 m rolls polymeric cable cover				151084
300mm x 10 m rolls polymeric cable cover				151092
200mm x 25 m rolls polymeric cable cover				H74930
750 x 200 x 6mm Galv. mild steel plate				71464
150mm x 100 m roll orange polythene warning tape to drawing no. 49070				71233
Ragbolt Assembly:				
Ragbolt assembly				H5880

Item	Stockcode
Heatshrink End Caps:	
Heatshrink end caps (lined) for cable diameters in the range 3mm to 8mm	62232
Heatshrink end caps (lined) for cable diameters in the range 4mm to 8mm	62166
Heatshrink end caps (lined) for cable diameters in the range 8mm to 17mm	176801
Heatshrink end caps (lined) for cable diameters in the range 13mm to 22mm	62117
Heatshrink end caps (lined) for cable diameters in the range 17mm to 30mm	180005
Heatshrink end caps (lined) for cable diameters in the range 28mm to 50mm	62067
Heatshrink end caps (lined) for cable diameters in the range 38mm to 70mm	62042
Heatshrink end caps (lined) for cable diameters in the range 65mm to 95mm	62026
Heatshrink end caps (lined) for cable diameters in the range 95mm to 115mm	178062
Heatshrink end caps (unlined) for cable diameters in the range 95mm to 115mm	62208
Heatshrink Tubing:	
Heatshrink tubing for cable diameters in the range 14mm to 31mm	60186
Heatshrink tubing for cable diameters in the range 20mm to 45mm	143776
Heatshrink tubing for cable diameters in the range 27mm to 55mm	141721
Heatshrink tubing for cable diameters in the range 50mm to 100mm	169565
Triple End Seals:	
Triple End Seal Kit for 95mm ² to 240mm ² Multicore Cables	178442
Triple End Seal Kit for 300mm ² to 500mm ² Multicore Cables	178441
Triple End Seal Kit for 185mm ² to 300mm ² High Voltage Single Core Polymeric Cables	178443
Triple End Seal kit for 185 to 300 mm ² LV Single Core Polymeric Cables	182467
Cable Clamps for Polymeric Cables:	
Nitrile Rubber Liner to be used with all Cable Clamps for Polymeric Cables	179201
Single Core Cable for attachment to Unistrut – 70mm ²	179212
Single Core Cable for attachment to Unistrut – 300mm ²	179211
Single Core Cable Held in Flat Arrangement – 300mm ²	180350
Single Core Cable Held in Flat Arrangement – 185mm ²	180291
Single Core Cable Held in Quad Arrangement – 185mm ² LV Parrot Cable	179213
Single Core Cable Held in Trefoil Arrangement – 70mm ²	179491
Single Core Cable Held in Trefoil Arrangement – 185mm ²	178988
Single Core Cable Held in Flat Arrangement – 630mm ² to 1000mm ²	182114
Single Core Cable Held in Trefoil Arrangement – 300mm ² to 630mm ²	178987
Single Core Cable Held in Trefoil Arrangement – 1000mm ²	182134
Stainless Steel Band Type – Part No ABB:EA-UKR100	177651

Annexure H – CBD 16 Way Conduit Line

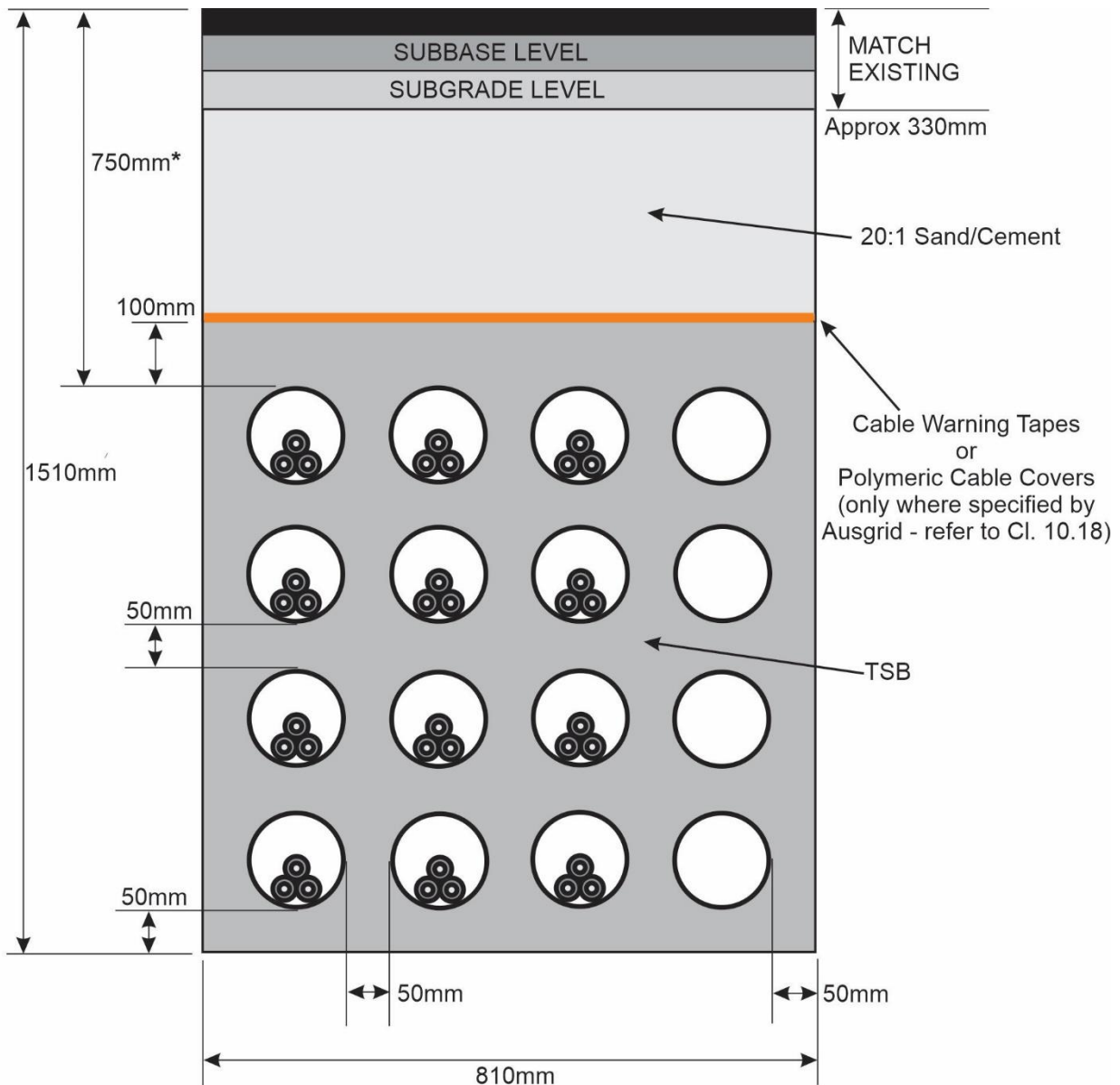

4x4 125mm ID DUCT, TRENCH WITH TSB BEDDING - TYPICAL DETAILS

Figure H1

Details

Cable: 300mm² Cu Triplex

Ducts: 125mm UPVC

Backfill: 20:1 sand/cement dry mix

Bedding: thermally stable bedding slurry (TR = 0.9K.m/W or less, fully dry).

* Required cover may vary to suit Council or RMS requirements. Cover could be as high as 1.0m for RMS roads.

Annexure I – Typical Final Restorations

Table I1: Carriageway or Heavy Duty Vehicular Crossing

Backfill Zone	Backfill Zone Thickness	Backfill Material	Compaction Requirement			
Final wear surface	Match existing	Match existing	Match existing	98% MMDD or 102% MSDD		
Base course	Match existing	Base as specified	Match existing	98% MSDD or 95% MMDD Density Index 80%		
Sub-base course	Match existing	Sub-base as specified	Match existing	As specified in Clause 14		
Below sub-grade	Varies	As specified in Clause 14	Varies	As specified in Clause 14		
Bedding zone	As per Notification Plan and this Network Standard	As per Notification Plan and this Network Standard	As per Notification Plan and this Network Standard			

Reinstatement width in accordance with specification (indicated by a double-headed arrow on the left side of the diagram)

Finished Surface Level (indicated by a dashed horizontal line)

Sub-base Level (indicated by a dashed horizontal line)

Sub-grade Level (indicated by a dashed horizontal line)

The diagram shows a cross-section of road layers. From top to bottom: a grey concrete surface with a circular manhole opening; a layer of bedding material; a sub-grade layer; a sub-base layer; a base course; and a final wear surface. The 'Reinstatement width' is shown as the width of the bedding and sub-grade layers. The 'Finished Surface Level' is the top of the concrete surface. The 'Sub-base Level' and 'Sub-grade Level' are indicated by dashed lines.

Table I2: Typical Restorations in Footpaths

Zone	Zone Thickness	Material	Compaction Requirement
Final wear surface	25 MPa concrete – 75 mm MIN or match existing AC5 Asphalt – match existing Segmental paving units – match existing		
Footpath pavement sub-base	Match existing thickness (minimum 50 mm)	Fine crushed rock	92% MMDD or 95% MSDD
Below sub-grade	Varies	As specified in Clause 14	90% MMDD or Density Index 70%
Bedding zone	As per Notification Plan and this Network Standard	As per Notification Plan and this Network Standard	As per this Network Standard

Annexure J – Installation of Network Conduit Lines through Buildings

Introduction

This section deals with Ausgrid's requirements where a bank of conduits is intended to carry distribution Network Cables through a building. It is anticipated that this situation would arise mainly in Central Business Districts where street congestion begins to limit the ability to effectively provide supply to all customers.

Definitions

Network Cables	415V and 11kV cables required to supply parts of Ausgrid's network other than just the building through which they are passing.
Ductline	A group or bank of conduits suitably spaced for required cable ratings and installed so that heat generated by the cables may be effectively dissipated. The cables are required to be protected from the effects of a fire in the building through which they pass, either by encasement in suitable materials or shielding and separation from sources of fire.

Property requirements

Where a bank of conduits are to be run through a privately owned building, an easement covering the route and a right of way to permit access must first be negotiated as per NS143 and applicable Property Branch documents. The easement would normally be a stratum easement, confined to the boundaries of the materials encasing and supporting the conduits.

Policy

Wherever possible, Network Cables shall be routed through public roads or reserves in accordance with NS143 *Easements and Leases* and NS130 *Laying Underground Cables up to and including 11kV*.

However, where situations arise such that it is difficult to provide supply to all customers in this manner, Ausgrid may determine that space is required through new or existing buildings for the construction of a Ductline. This new Ductline would not be intended to exclusively supply the customers in that building.

In such cases, other network customers are exposed to an additional risk of wider spread loss of supply in the uncommon event of a fire or catastrophic incident occurring within the building and impacting on the availability of the Network Cables passing through the Ductline.

It is therefore necessary that a policy be developed and requirements specified to ensure that Network Cables running through buildings are installed in such a manner that they are protected as far as possible from accidental damage and the impact of a catastrophic incident. If damaged, the Network Cables should be installed so that they are capable of being quickly restored to a serviceable condition.

Functional Requirements

The installation conditions should be such that the performance of the cables is not compromised by the additional measures required to protect them. The cable protection shall be such that the cables are capable of being quickly removed or replaced in the event of a major building failure.

Ausgrid's policy in this regard is as follows:

- Where Network Cables are to be run through a Ductline located inside a building, the Ductline shall be designed to provide at least a 3 hour fire rating (FRL 180/180/180) for the Network Cables unless special circumstances mitigate the risk of the Ductline being exposed to the fire.
- At the end of 3 hours fire exposure, it shall be possible to withdraw existing cables installed in the Ductline and to install new Network cables without difficulty.
- The Ductline and supporting structures shall be protected against a 2 kPa overpressure generated from within the building area.
- Any proposed reduction in the fire protection or overpressure requirements shall be subject to the written approval of Ausgrid.
- Where the above requirements are not fully achievable, or where there is considered a more significant potential consequence to the cables or conduits being severely damaged, the relevant section of Ductline shall be readily accessible. The conduit encasement shall be designed for ease of demolition so that it can be replaced or repaired in order to facilitate the speedy replacement of Network Cables contained in the Ductline. Alternative solutions such as the provision of an alternative back up route may also be considered acceptable.
- While adequate fire and overpressure protection is to be established for the Ductline, the form of protection proposed shall not adversely impact on the design cable ratings of the Network Cables passing through the building. In particular, the thermal resistivity (TR) of the conduit encasement shall not be greater than that specified for the project.
- Any Ductline design that may adversely impact on the designed cable ratings, shall have a rating assessment completed by the Designer as per NS 272 and the rating assessment shall be submitted to Ausgrid for review and written approval.

Minimum technical requirements

A. Internal Building Areas with LV and HV Conduits Above Ground and Exposed to Air

The following technical requirements are based on a concrete encased Ductline design. Alternative arrangements which provide the necessary protection and do not reduce cable ratings to unacceptable levels may also be submitted for consideration by Ausgrid.

1. The conduits shall be 150mm (160mm OD) heavy duty UPVC Orange and shall meet the minimum requirements of NS130 and AS 2053
2. Minimum conduit centre to centre spacing shall be 230mm
3. The conduits shall be encased in concrete with all exposed faces suitably reinforced. A high concrete density is required and lightweight aggregate and air entraining agents shall not be used.
4. A minimum three (3) hour (FRL 180/180/180) fire rating shall be achieved for the concrete encasement to the conduits and for any supporting structures. This requirement may be reduced in fire isolated areas such as fire stairs subject to approval from Ausgrid.
5. The conduit ductline and supporting structures shall be designed to sustain a minimum superimposed live load of 2 kPa overpressure, generated from within the internal building area.
6. A minimum concrete cover of 180mm to the conduits shall be provided at all exposed concrete encasement faces. This concrete cover shall be suitably reinforced and incorporate the required 3 hour fire rating. Reinforcement detailing shall be arranged to reduce the potential for induced currents in accordance with the requirements of Ausgrid.
7. A minimum concrete cover of 100mm to the conduits shall be provided at non-exposed faces of the Ductline, for example, along external basement walls. This cover may be reduced in confined locations subject to approval from Ausgrid.

8. Suitable allowance shall be made for conduit installation and support along the Ductline route.
9. The use of core filled blockwork to form the exposed faces of the ductline is not acceptable due to its higher thermal resistivity. Blockwork may be used below the Ductline for support provided a 3 hour fire rating and 2 kPa overpressure resistance is achieved by the support structure.
10. All exposed faces along the route of the internal Ductline shall have suitable marking to the requirements for reduced cover specified in NS130, and approved by Ausgrid.
11. Internal building areas through which the ductline passes shall be suitably ventilated or air conditioned to allow for effective circulation of air to all exposed faces and to remove heat generated by the cables. Design information to be provided by Ausgrid shall include the estimated heat load per metre for the Ductline being designed.

B. Internal Building Areas with LV and HV Conduits Below Ground in Trenches

1. The conduits shall be 150mm (160mm OD) heavy duty UPVC Orange and shall meet the minimum requirements of NS130 and AS 2053
2. Minimum conduit centre to centre spacing shall be 230mm
3. The conduits shall be encased in Thermally Stable Bedding (TSB) or concrete. Where concrete is used a high concrete density is required and lightweight aggregate and air entraining agents shall not be used.
4. A minimum cover of 100mm for the conduits shall be provided to the trench walls and floor. This cover may be reduced in confined locations subject to approval from Ausgrid. Minimum cover below the internal floor surface shall all be in accordance with NS130 requirements including those for reduced cover.
5. Within the building area all conduit trenches shall be provided with a reinforced concrete slab at the surface with a minimum thickness of 125mm.
6. Marking of the route of the Ductline on the floor surface shall be required as shown in NS130 and approved by Ausgrid for all internal Ductlines.
7. Internal building areas above the conduit trenches shall be suitably ventilated or air conditioned to allow for effective circulation of air and remove heat generated by the cables.

C. Concrete Requirements

Concrete used for encasement of ductlines shall be specified to ensure that it provides the required mechanical strength and fire rating, while not adversely impacting the thermal ratings of the cables. In particular, the following requirements must be adopted in designing the concrete mix:

1. The specific concrete specifications required for the concrete encasement of the Ductline are to be indicated on the drawings. Ausgrid's requirements, including those indicated below, shall be referenced.
2. The minimum concrete strength for the encasement shall be 20MPa at fire exposed locations and shall be indicated on the drawings. To limit the heat of hydration, the cement content should be minimised to the extent possible given the other design requirements.
3. A low heat of hydration cement (Type LH) and appropriate concrete mix design shall be used to reduce the risk of the UPVC conduits softening during curing. Other measures to further limit the temperature rise in the concrete encasement during curing may be acceptable subject to approval by Ausgrid.
4. Admixtures in the concrete mix shall be subject to the approval of Ausgrid following the submission of a product specific data sheet. The use of accelerators to speed concrete curing or admixtures that entrain air will not be approved.
5. The total flyash in the concrete mix (by weight) shall not exceed 5% unless separately approved by Ausgrid. Flyash reduces the thermal performance of the installed Ductline.
6. Lightweight aggregate and air entraining agents shall not be used.

7. The concrete cover to reinforcement shall comply with AS 3600 to achieve a minimum three (3) hour (180/180/180) fire rating. Ausgrid requires a minimum concrete cover of 45mm to reinforcement at any fire exposed face.
8. Reinforcement detailing shall be arranged to reduce the potential for induced currents. In particular, transverse reinforcement around the Ductline shall not form a closed loop at any location.

ASPs or contractors wishing to vary concrete mix from approved requirements shall provide documentation demonstrating that their proposal achieves the specified functional requirements including Ductline integrity and thermal resistivity (TR) value without increasing the in-situ concrete curing temperature to a level where conduits are likely to be damaged.

D. Electric and Magnetic Fields (EMFs) and Electromagnetic Interference (EMI)

The selection of the route for network ductlines through buildings should take into account the possible effects of Electric and Magnetic Fields (EMF) and Electromagnetic Interference (EMI). The adjacent, current and expected building and land uses and locations of Ductlines and cables should be evaluated for EMI.

Evaluation by an approved Electrical Engineer is to be undertaken to ensure EMI does not disrupt sensitive electronic equipment or pose a health risk to persons who continuously occupy adjacent areas for long periods of time.

An EMI report must be provided as part of the design submission for the proposed Ductline.

Areas of particular relevance include hospitals, particularly operating theatres (Refer to AS/NZS 3003), computer rooms, laboratories, general offices and apartments.

Refer to NS114 for additional requirements and guidance.

Note: Installation of EMI screening is not permitted inside any Chamber Substation, at any HVC connection, or associated chambers and cable risers. The addition of EMI screening at other locations must not interfere with access to, maintenance of, air circulation around or the efficient operation of the Ductline and related equipment.

Annexure K – Testing of Backfills: Thermal Resistivity

Background

Ausgrid has a high capital investment in underground cables.

The ratings of these buried cables are greatly affected by the thermal properties of the surrounding soils and imported thermal bedding materials.

Thermal resistivity (TR) is a major input parameter into cable rating calculations and a thorough understanding of the resulting values during construction is vital to ensure the specified cable ratings are achievable over the lifetime of installed assets.

Ausgrid wishes to ensure that the TR testing services being offered by external service providers are accurate and consistent, providing test results that can be relied on for its determination of cable ratings.

This document has been developed with the intent that the quality of TR testing being offered by external service providers is of a standard compatible with Ausgrid's requirements. Information is included to assist Testing Laboratories experienced in soil analysis but no thermal studies to understand the basis for the requirements and procedures specified.

Thermal resistivity (TR)

Thermal resistivity (TR) is the reciprocal of thermal conductivity.

Thermal resistivity (TR) is a property of the material being tested.

Thermal resistance depends upon the TR of the material AND the geometry of the installation

TR is often measured in either Km/W or °C.m/W, the units depicting temperature rise across a given distance due to an amount of heat(power) passing through the medium.

Regardless of whether K or °C are used, the magnitude of the TR will be the same.

For a given geometry: the higher the TR the greater the resistance to the flow of heat and, for a given amount of heat the greater the temperature rise.

The formula used to calculate TR for a line heat source of infinite length within an infinite medium is:

$$\rho = \frac{4 * \pi * (T_2 - T_1)}{2.303 * q * \log(t_2/t_1)}$$

Where:

ρ	= TR in K.m/W (or °C.m/W)
T_1 and T_2	= Temperatures at the beginning and end of the test period respectively
q	= Heat dissipated by the line heat source in watts/m
t_1 and t_2	= Times at the beginning and end of the test period in minutes

The qualifying factors that apply to the above expression should be noted as:

Thermal probes are not line heat sources and have physical diameters and wall thickness. The resulting mass and specific volumetric heat of the probes causes non linear relationships between temperature and log (time differences) at the initialisation of tests.

Scope

The scope of this document covers information relating to the necessary processes for ensuring that testing of thermally stable materials or soil samples is conducted in a manner that provides accurate and consistent results regardless of the Testing Laboratory undertaking the tests. In particular, the document includes information on:

- Tests to be Undertaken on Samples
- Quality of Test Procedures
- Sample Preparation
- Storage of Samples
- The development of thermal bedding materials
- General equipment needed

Tests to be undertaken on samples

Tests to determine the thermal characteristics and performance of bedding materials for use in Ausgrid projects shall be generally in accordance with:

ASTM D5334-08 Standard Test Method for Determining the Thermal Conductivity of Soil and Soft Rock by Thermal Needle Probe Procedure.

Note that results from this method are for thermal conductivity, and it will be necessary to take the reciprocal of this value to calculate the thermal resistivity, which is the value generally used in Australia for cable installations.

Ausgrid require the following tests to be undertaken and results provided for samples for which thermal resistivity is being determined.

For native soil samples:-

- Thermal resistivity – as found
- Moisture content – as found
- Thermal resistivity – in the fully dried out state
- Thermal dryout curves – Thermal resistivity vs Moisture content.
- Soil density – as found

The density of native soils may not always be required. When commencing work on projects the Testing Laboratory should confirm that Ausgrid requires native soil density results.

For compacted granular thermal bedding materials (including graded sands) submitted for approval or routine testing:

- Thermal resistivity at a specified compaction density
- Moisture content – when compacted
- Proctor density of the compacted sample
- Thermal resistivity in the fully dried out state
- Dry Density

For flowable thermal bedding materials submitted for approval or routine testing:

- Thermal resistivity at commencement of testing
- Moisture content at commencement of testing
- Thermal resistivity in the fully dried out state
- Dry Density

Where the material is being submitted for approval (type testing), a dry out curve may also be required, recording moisture content and thermal resistivity at; zero moisture content, initial

moisture content and at least two points in between. The initial moisture content shall be not less than 8%.

For compacted granular materials, the minimum Proctor density of samples shall be specified by Ausgrid. If not specified, the value shall be 98% Standard Proctor density. For material submitted for approval (type testing) the fully dried out TR shall also be determined at 95% and 90% standard Proctor density.

Sieve analysis may also be required when instigating projects the Testing Laboratory should confirm that Ausgrid requires sieve analysis results.

Provision of test reports

Results are to be provided to Ausgrid in an uneditable electronic format (e.g. pdf file) for storage and access by Ausgrid staff in Ausgrid's ThermalRes database.

Quality of test procedures

Notwithstanding any standard, process or equipment used the Testing Laboratory must at all times be able to demonstrate to the satisfaction of Ausgrid that the methodologies and equipment used for the determination of the thermal resistivity of soils will provide accurate and repeatable test results.

The following references shall be used in place of the comparable US standards where referenced in ASTM D5334-08:

- AS 1289 5.1.1-2003: Method of Testing Soils for Engineering Purposes – Soil compaction and dry density Tests.
- AS 1289 2.1.1-1992: Method of Testing Soils for Engineering Purposes – Soil moisture content tests
- AS 1289 1.1.1-2001: Method of Testing Soils for Engineering Purposes – Sampling and preparation of soils.
- AS 1012.3.1 – 1993: Methods of Testing Concrete. Determination of properties related to the consistency of concrete – Slump test
- AS 1379 – 1997 Specification and supply of concrete

Factors that influence test results

Test samples are also not infinite mediums (often being as small as 50mm in diameter). Boundary effects occur during tests as the heat flux reaches the outer surface of the sample where it often interfaces with air.

There are many factors that can influence test results such as:

- Moisture migration within the sample under test due to the heat from thermal needles can affect the rates of temperature rise
- Non stable sample temperatures affect the flow of heat generated by the probe
- Poor probe surface contact resistance with the surrounding aggregates can influence results due to situations such as: aggregate size, compaction, cracked samples or incorrectly installed thermal needles
- Poorly prepared samples where in the case of compacted granular materials the density of the material is inconsistent with the expected density

For these reasons when assessing the resulting values (or more fundamentally, the time periods over which analysis is to occur) a visual representation of the temperature/log time output must be referred to, to ensure initial and transient boundary effects have been considered and their effect on the TR result minimized.

Equipment

Thermal Resistivity Test Instruments.

Refer to part 5 of IEEE 442-1981 *Guide for Soil Thermal Resistivity Measurements* for general information on test equipment for use on TR testing.

Whilst the determination and analysis of TR can be achieved using relatively simple equipment, modern instrumentation usually incorporates constant current power sources and data logging facilities together with computer assistance to output a TR quantum.

Due to the effects of initial transients and edge effects, only those instruments that can demonstrate to the satisfaction of Ausgrid that these effects have been considered and eliminated in the determination of TR shall be approved for carrying out TR measurements.

Thermal needle length to diameter ratio shall be no less than: 30:1.

The contractor may be required to perform a practical demonstration of the instrumentation offered and shall be required to provide specifications for the equipment to be used for testing samples for Ausgrid.

A list of the key equipment expected to be required by Testing Laboratory in carrying out TR measurements for Ausgrid is provided in Table L1.

Sample preparation

The preparation and handling of samples has a great influence on the resulting TR.

Due to the relatively small size of commonly prepared samples the scaling effects on mix tolerances can lead to inaccuracies when specifying delivered quantities.

The measuring tolerances of equipment and methodologies used to prepare samples shall be suitably controlled to minimize scaling errors.

- The measurement accuracy of Thermal Resistivity shall be: < +/- 5%
- Routine daily calibration checks of balances shall be carried out using known test weights.
- The measurement accuracy of balances shall be: < +/- 1%
- The minimum diameter of samples to be tested shall be: 50mm
- The minimum length of sample to be tested shall be: 150mm
- Larger samples are preferred

Compacted Granular Samples

For a given material type the TR of compacted granular materials is usually quite sensitive to both compaction density and moisture content.

For results to be accurate and repeatable the compaction of samples must be well controlled.

Testing Laboratories must have systems in place to ensure:

- The positioning of test probes within the samples being prepared is controlled to prevent movement of the probes during compaction
- The density of the compacted material within the sample is consistent throughout the sample volume.
- Sample compaction is carried out at known moisture contents (as a percentage of dry weight)

For these reasons samples must be prepared in controlled layers where the mass of the material being compacted within each successive layer volume is known. Quality balances must be used to accurately measure the mass of material used within the layered samples.

Samples shall be taken from site or prepared from ingredients in accordance with AS 1289.1.1.1. When placed in the test cylinder, compaction shall be tested in accordance with AS1289.5.1.1.

Compaction rates and the densities must be referenced to standards to ensure repeatability in the field i.e. Standard Proctor Test.

Where a dryout curve is being prepared, moisture content shall be tested at the beginning and end of tests, as well as at additional points in between. Testing for moisture content shall be in accordance with the requirements of AS1289.2.1.1.

Flowable Samples

The collection and treatment of fluidised samples before solidifying can have marked effect on the TR of the sample under test. The aggregates within these high slump materials (designed such that they should flow without mechanical vibration) can easily segregate under vibration. The consistency of the collected sample under test must be representative of the material installed within the cable trench and for this reason, further movement/vibration caused by influences such as but not limited to:

- Rodding
- Transport
- Tapping the sample tube

should be avoided until the material has solidified to prevent aggregate segregation. Collected samples are usually best left on site until solidified before transporting to a test laboratory for further testing.

Probe Installation and Collection of Undisturbed Soil Samples

The installation of thermal needles/probes must be done with a view to ensuring good contact between the needle and the surrounding material without disturbing the soil.

Poor contact between the thermal needle and surrounding material will greatly affect the TR measurement.

If the sample material is so hard as to require the drilling of a hole to permit installation of the needle without damage to the needle or disturbance to the sample, the hole shall be of slightly smaller diameter than the needle to ensure that the needle maintains a good contact with the sample throughout its length.

The most common method used for collecting undisturbed samples is via driven tubes. These tubes must comply with the minimum dimensions specified above.

The tubes used must be thin walled (nominally 1.0mm) and driving operations undertaken with processes that prevent inadvertent compaction of the collected sample.

Note: Driving thermal needles and sample tubes into native soil within the field environment bring with it the risk of damaging other services. The Contractor's attention is brought to the necessity to locate services before driving probes, collection tubes or drilling holes for needles. The cost of rectification of any damage caused by the contractor in carrying out probe installation or the collection of samples shall be borne by the contractor.

Storage of samples

The Test Laboratory shall have in place suitable storage facilities for the preservation and storage of test samples.

Following final tests, samples are usually discarded, however there may be a requirement for samples to be stored for a period of time for records and/ or retest either by the Test Laboratory or by others.

The maximum time samples are required to be stored is: 6 weeks.

For samples to be stored by the Test Laboratory, Ausgrid must issue notice to the Test Laboratory no less than 2 weeks prior the commencement of testing that samples are to be stored. At the completion of the storage time the Test Laboratory may discard the samples unless within the

6 week storage period notice has been given by Ausgrid that prolonged storage of samples would be required.

- The maximum prolonged period of storage (including the initial 6 weeks) shall be 12 weeks.
- The minimum volume to be allocated for the storage of samples shall be 24m³.

The storage facility shall be in a cool dry place with security and appropriate filing to prevent the loss and ensure proper identification of samples for the storage period.

At the end of the storage period the Test Laboratory may discard the samples and/or hand them over to Ausgrid at Ausgrid's discretion.

Development of thermal bedding materials

Once a mix design for thermal bedding or backfill material has been determined within the laboratory, and constituent components specified to a level such that variation in the delivered material prevents the resulting TR from exceeding Ausgrid's specified maximum TR for the project in hand, before it can be used on Ausgrid's network it must be type tested in the following manner.

Samples for type testing shall be collected from a batched mix of no less than 2m³ with no less than 3 samples for TR testing being taken from the beginning, middle and end of the batched product (a total of 9 samples for thermal testing plus additional samples for compressive strength tests). The first 0.2m³ of the batch mix shall be run off before the samples are taken.

Test reports for these materials shall include:

- Detail description of the constituent components
- Sieve analysis
- Identification of the source quarries and batching plants
- Mix design (in kg/m³ – dry weight)
- Water content in litres/m³ or % dry weight
- Compressive strength at 7, 28 and 120 days (with strength values to be within the ranges required by Clause 11.2) at the minimum and maximum site acceptable slump (moisture content) values.
- Thermal Resistivity in the fully dried out state in Km/W (for materials mixed at the minimum and maximum site acceptable slump (moisture content) values.
- Methods used for the sample preparation and installation to ensure the type test results are representative of the "in field installed" materials.

For compacted granular mixes only:-

- Compaction density to be used on site as a % of the Standard Proctor Density (used to achieve the type test results for compacted granular materials)

For flowable type mixes only:-

- Nominated slump (in the case of fluid type product) to be used on site
- Forecast Compressive strength @ 6, 12 and 24 months at the minimum and maximum site acceptable slump (moisture content) values.

Six cylindrical samples nominally 100mmD * 150mm long shall also be provided for inspection by Ausgrid.

The type test results (including the 28 day compressive strength results) together with work method statements (WMS) for their installation for controlled thermal bedding together with samples, shall be provided no less than 6 weeks prior to first installation.

Quality Management Plans

Testing Laboratories undertaking TR testing must have in place, accredited or approved quality systems documenting the:

- Work method statements for each of the individual processes being undertaken

- Test report formats
- Equipment list that positively identifies the equipment used and the accuracy of the instrumentation provided
- List of key personnel undertaking TR testing and sample preparation
- Methods used to calibrate instrumentation, including calibration frequency

Ownership and treatment of samples

Samples provided by Ausgrid shall remain the property of Ausgrid until testing is completed and samples are discarded.

Samples collected by the Test Laboratory or contactor for testing shall remain the property of the Test Laboratory until full payment of the testing services is received.

From the time of receipt of samples the Test Laboratory shall ensure that the samples are maintained within a controlled environment and treated such that the variation in TR results due to storage are minimized. For this reason bulk samples shall be stored in sealed enclosures to prevent moisture loss and or migration of moisture within the sample itself.

Right of access

Ausgrid reserves the right to witness any testing being carried out on its behalf, whether this testing is on site or within laboratories.

Ausgrid reserves the right to audit any testing or equipment that may be used for testing samples on its behalf. The cost of auditing will be to Ausgrid who will provide reasonable notice to the Test Laboratory for the audit.

Confidentiality

The Test Laboratory must have in place quality systems to guarantee the confidentiality of tests carried out on Ausgrid's behalf.

Table K1: Typical Equipment

Item	Equipment	Description / Use
1	TR test instrumentation	Suitable constant power sources (adjustable) with temperature/log time data logging facilities. Output results to be able to be confirmed by graphical output.
2	Thermal needles probes	Thermal probes/needles with a length to diameter ratio of > 30:1 capable of withstanding oven temperatures $\geq 105^{\circ}\text{C}$. Sized to suit field and laboratory situations.
3	Forced air oven	Used for drying out and stage drying samples (at up to $105^{\circ}\text{C} \pm 2.5\%$) as well as treating soil samples at elevated temperatures prior disposal in accordance with the NSW department of agriculture specifications.
4	Balance and calibration test weights	$\pm 0.01\%$ for accurately weighing component materials and mixtures.
5	Sieve / shaker -	Multistage vibrating sieve up to 25mm sieve sizes.
6	Standard proctor compaction hammer and test cell	These standardized items (to AS 1289 – Methods For Testing Soils For Engineering Purposes) are used for the laboratory compaction and density measurement of samples.

Item	Equipment	Description / Use
7	Field sample tubes with sealing caps	50mmd * 150mm long Stainless steel tubes for the collection of undisturbed field samples with "in-situ/natural" density or allowing uncontrolled drying out of test samples.
8	Laboratory sample tubes and compaction equipment	For accurately preparing compacted granular samples with consistent density throughout the sample.
9	Slump cone and tamping rod	Used for determining the standard slump of "fluid" materials.
10	Measuring cylinder	0-500ml \pm 0.5ml measuring cylinder for accurately measuring the required moisture component of samples under manufacture.
11	Manuals and work instructions	Quality assurance for equipment calibration and work procedures.

Annexure L – Typical TSB Recipes

The following are typical examples of slurry mix designs that may satisfy the performance requirements of Clause 11.2:

Table L1: Regular Mix Recipes - Compressive Strength: 1 to 3MPa

Component	Wt.(kg/m ³) SSD*
Cement	20
Fly Ash	160
Coarse Aggregate - Round River Gravel	925
Fine Aggregate	985
Water	200

Table L2: Regular Mix Recipes - Compressive Strength: 3 to 5MPa

Component	Wt.(kg/m ³) SSD*
Cement	70
Flyash	100
10mm crushed river gravel	970
Coarse Sand	930
Water	190

Table L3: Dry Mix Recipe

Component	Wt.(kg/m ³) SSD*
Cement	25
Fly Ash	140
Coarse Aggregate - 10mm aggregate	725
Fine Aggregate	1095
Water	105

* SSD = Saturated Surface Dry - the condition of the aggregate in which the pores in each particle of the aggregate are filled with water but no excess water is on the particle surface.