

# Network Standard

Document No.

**NS168**

Title:

**Design of 33kV, 66kV and 132kV Underground Cables**

Approved Date	1/05/2025	Revision	9	
Lifecycle Stage	Design	Internal Use	<input checked="" type="checkbox"/>	External Use <input checked="" type="checkbox"/>
Technical Approver		Authorised By		
Name	Duminda Thenuwara	Name	Jacob Bayley	
Designation	Senior Engineer	Designation	Manager Network Standards and Electrical Safety	

## Revision

No	Date	Description	Technical Approver	Authorised By
9	1/05/2025	Converted to new Network Standard template, Added a new Annexure C - Installation of sub-transmission cables and fibre optic cables in private buildings	Duminda Thenuwara	Jacob Bayley

## DISCLAIMER

This document is bound to the conditions set out in NS002 Network Standards Disclaimer.

Ausgrid maintains a copy of this and other Network Standards together with updates and amendments online at [www.ausgrid.com.au](http://www.ausgrid.com.au). This document is considered uncontrolled once printed.

## Table of Contents

Scope .....	3
Reference Documents.....	3
Ausgrid Documents .....	3
Other Standards and Documents .....	4
Acts and Regulations .....	4
1 Development brief.....	5
2 Design documentation .....	5
3 Survey.....	6
4 Route selection.....	7
5 Electrical design.....	8
6 Construction .....	24
7 Final Project Documentation .....	27

## List of Annexures

Annexure A : List of drawings.....	A-1
Annexure B : Kooragang Island Design Requirements .....	B-2
Annexure C : Installation of sub-transmission cables and fibre optic cables in private buildings.....	C-5

## Scope

This Network Standard provides technical information in relation to Ausgrid's requirements for the design, construction and installation of underground sub-transmission lines and modifications to existing underground sub-transmission lines. In addition, work under this Standard is to be carried out subject to and in accordance with any plans, drawings and documents that may be provided as part of the Development Brief.

This Network Standard does not cover construction requirements, authority approvals, safety or environmental requirements relating to construction works. Normal industry practices apply in addition to any Ausgrid design requirements detailed herein.

## Reference Documents

All work covered in this document shall conform to all relevant Legislation, Standards, Codes of Practice and Network Standards.

## Ausgrid Documents

NS001 Glossary of Terms

NS100 Field Recording of Network Assets

NS104 Specification for Electrical Network Project Design Plans

NS116 Design Standards for Distribution Equipment Earthing

NS130 Laying Underground Cables up to and including 11kV

NS143 Easements, Leases and Rights of Way

NS156 Excavating Near Ausgrid Underground Cables or Conduits

NS159 Installation of Cables and Conduits using Trenchless Techniques

NS165 Safety Requirements for Non-Electrical Work in and around Live Substations

NS167 Positioning of Poles and Lighting Columns

NS172 Design Requirements for Cable Jointing Pits, Vaults and Bays

NS181 Approval of Materials and Equipment and Network Standard Variations

NS204 Communication Pits - Specifications and Installation

NS205 Telecommunications Route Markers

NS220 Overhead Design Manual

NS234 Telecommunications - Underground Physical Plant Installation

NS260 Sub-Transmission Feeder Earthing

NS268 Specification for Design and Construction of Waterway Crossings

NS272 Cable Rating

## Other Standards and Documents

AS/NZS 3835:2006 Earth potential rise – Protection of telecommunications network users, personnel and plant.

AS 3996 Access covers and grates.

AS/NZS 4853:2012 Electrical hazards on metallic pipelines.

EA ER C55/5 -Electricity Association Engineering Recommendation - Insulated Sheath Power Cable Systems.

IEC 60287 Calculation of the continuous current rating of cables (100%) load factor.

IEC 62271-209 High-voltage switchgear and controlgear - Part 209: Cable connections for gas-insulated metal-enclosed switchgear for rated voltages above 52 kV - Fluid-filled and extruded insulation cables - Fluid-filled and dry-type cable-terminations.

### **Acts and Regulations**

Electricity Supply (General) Regulation 2014 (NSW).

Electricity Supply (Safety and Network Management) Regulation 2014 (NSW).

Environmental Planning and Assessment Act 1979.

State Environmental Planning Policy (SEPP) Infrastructure 2007.

The Roads Act 1993, as amended.

Work Health and Safety Act 2011 (NSW).

Work Health and Safety Regulation 2017 (NSW).

## Clause Standard Requirements

### 1 Development brief

1.1 Ausgrid shall determine the need for any new or modified sub-transmission lines, and whether the work is contestable, and shall prepare a Development Brief (see Note) document, defining the scope of the project and detailing specific information relevant to the project.

**Note:** In the case of contestable work, the Development Brief is the 'Design Information', as defined by IPART.

1.2 Ausgrid will prepare the Development Brief for each new section of a sub-transmission line project. It shall include the following information where applicable:

- Project scope and description.
- Required completion date, if applicable to satisfy system loading requirements.
- Operating voltage.
- Rating requirements, including provision for other circuits in close proximity, feeder route options, corridor widths and trench boundary maximum operating temperatures if required.
- Proposed route or endpoints.
- Environmental GIS report.
- Details of power cables, including any requirements for compatibility with existing cable installations, eg extensions to oil-filled cables.
- Details of communication cables, including any requirements for interfacing with existing systems.
- Any project-specific design or construction requirements/constraints, eg the need for 200mm ducts to allow for future network construction.
- Where required, the number of spare conduits shall be specified, refer to the Note below.
- Segregation requirements for multiple circuits along a common route.
- Allowance for additional circuits, or conduits, if applicable.

**Note:** Ausgrid may require spare conduits alongside new circuits to cater for known future network enhancements. The practice of installing spare conduits as 'operational spares', to provide alternate conduits during cable repairs, is not adopted at Ausgrid as the additional conduits can impede access to the cable during repairs and will increase the construction cost of the circuit. In cases where access is extremely limited (Rail Crossings, Water Crossings) and trenchless technologies are adopted, the installation of 'operational spare' conduits can occur and will be provided in the Development Brief.

### 2 Design documentation

The Proponent shall provide a design and all details in accordance with NS104 Network Project Design Plans and the Development Brief including but not limited to the following:

#### 2.1 Route plan

A route plan shall be provided showing the cable route on a cadastre plan, including dimensions from property boundaries if required for EMF calculations, the location of joint bays, pulling pits, link boxes and communications/DTS pits and existing services.

#### 2.2 Property schedule

Where easements are to be acquired or land purchased, a property schedule shall be prepared, giving details of the Lot and DP numbers (and street addresses where known) of all properties affected, name, postal address and contact phone number of property owners, and comments on the nature of the interest to be obtained and any agreements made with the property owner, such as access conditions, disposal of vegetation removed during line construction, etc.

### 2.3 Schematic

A schematic shall be provided showing feeder numbers, cable sections, joint bays, section lengths, cable types, accessory types and sheath bonding arrangements.

### 2.4 Design calculations

Design calculations shall include thermal ratings, short-circuit fault ratings, sheath voltage / currents and tension / sidewall pressure during pulling for all cables.

### 2.5 Cable details

Cable details shall include cross-section, dimensions, materials, thermal and electrical properties.

### 2.6 Cable accessory details

This shall include manufacturers' drawings and jointing instructions.

### 2.7 Factory test plan

This shall include test specification references and pass criteria for all sample and routine tests carried out in the factory on all cables and accessories.

### 2.8 Trench construction

This shall include trench cross-sections, backfill and reinstatement details.

### 2.9 Joint bay general arrangement

This shall include internal and external dimensions, location of joints, support details for cables and joints, bonding lead conduits, link boxes and earthing details.

### 2.10 Native soil details

This shall include results of soil sampling, geotechnical, earth resistivity and thermal resistivity testing.

## 3 Survey

3.1 A route survey shall be carried out before commencing any design work, this should include the following minimum information:

- Cadastre.
- Combined services information, from the designated underground asset information provider.
- Property ownership, eg DP/strata "F Plan" to identify any areas that are not gazetted as road reserve.
- Vertical profile if significant gradients are encountered that would adversely affect cable pulling tensions.

3.2 Borehole samples shall be taken from the preferred route for the purposes of:

- Thermal resistivity (TR) sampling at preferred intervals of 200m, or at changes in soil type, for rating calculations.
- Road pavement make-up, details of layer materials and thickness, for road restoration purposes.
- Characterisation of soil layers and environmental testing, for work method planning and waste classification.

3.3 Trial holes shall be excavated at survey stage to gain details of known obstructions / pinch points that may affect route viability.

## 4 Route selection

The optimum route shall be selected, based on an assessment of the following factors:

- Cost (usually minimised by selection of the shortest practical route).
- Availability of suitable joint bay locations.
- Major crossings (eg rail, water, major roads or other infrastructure).
- Community disruption (eg traffic, nightworks, location and number of impacted stakeholders).
- EMF prudent avoidance.
- Environmental issues (eg ecology, heritage).
- Easements.
- Specific site issues (eg contamination, poor soil properties).
- Community consultation.
- Construction timeframe.
- Existing services.
- Risks to cost and program.

Where multiple options exist, an options analysis shall be undertaken in accordance with the Project Development Manual.

### 4.1 Easements

- 4.1.1 Where possible, cable routes shall follow existing roads, and be contained within the carriageway of the road reserve.
- 4.1.2 Where considerable savings or other advantages may be obtained by traversing private property or other land not dedicated as public road, an easement shall be obtained to guarantee Ausgrid's security of tenure over the route.
- 4.1.3 The easement shall be negotiated and acquired in accordance with the requirements of NS143 Easements, Leases and Rights of Way, using Ausgrid's standard terms and conditions.
- 4.1.4 Easement widths shall normally be as specified in NS143, or in any supporting documentation prepared justifying the need for departure from these standards. All easements shall comply with Ausgrid's standard Deeds of Agreement for Easements.
- 4.1.5 Before any work commences on private property, the Proponent shall obtain written permission to enter from the land owners, and shall obtain agreement from the land owners for the planned route and dimensions of the proposed easement.
- 4.1.6 The easement shall be finalised as soon as possible after completion of the works, and shall be in accordance with an 'as built' survey which clearly indicates the location of the new construction works and the agreed easement boundaries on the private property.
- 4.1.7 Where, because of the route selected, the cable easement is not appropriate for vehicle access for maintenance or repairs, a Right of Way should be established at the same time, to ensure ongoing access for Ausgrid staff and contractors. Refer to NS143 for details of establishing a suitable Right of Way and Section 8.2 Access Tracks.
- 4.1.8 Where the route traverses a rail corridor, approval for the crossing shall be obtained from the appropriate Rail authority – either RailCorp or Australian Rail Track Corporation (ARTC). The Proponent is responsible for obtaining approval for the design of the crossing from the appropriate Rail authority in accordance with the requirements of the relevant Master Access Deed (MAD).
- 4.1.9 Where the route follows a classified road, the provisions of the Memorandum of Understanding between Ausgrid, RMS and Transport for NSW will apply.
- 4.1.10 Where the route crosses a waterway, the provisions of NS268 apply.

4.2 Substations

- 4.2.1 Activities within substation yards are strictly controlled and only undertaken by authorised personnel in accordance with defined procedures (eg NS156 and NS165).
- 4.2.2 Cables and conduits shall be installed within substations as per the requirements of NEG SM04.11 Specification for the Design and Construction of Major Substations - Power Cables and T0053 Specification for the Design and Construction of Major Substations - Power Cable Conduits. These documents are only available on the Ausgrid Intranet.
- 4.2.3 Reinforcement exclusion zones shall be applied around HV cables when penetrating through basement, pit or building walls - refer to drawing 202565.

5 Electrical design

5.1 General

- 5.1.1 All materials used on Ausgrid’s network shall be new and shall be installed by suitably trained personnel in accordance with Clause 6.1 of this standard.
- 5.1.2 Annexure B defines special requirements for new cable connections to the Kooragang Island 33kV distribution network, specifically the use of single core cables into kiosk switchgear. The requirements of each clause in Annexure B shall substitute for the corresponding clause in the main document (for example the requirements of Clause B.5.2 shall apply in place of Clause 5.2), and all other requirements of the main document shall still apply.

5.2 Cable types

- 5.2.1 New cable installations shall use cables with copper or aluminium conductor and XLPE insulation. The cable type shall be selected as follows:

**Table 1 – 132kV & 66kV cables**

Situation	Cable type
Normal feeders, eg in ductline	Smooth aluminium sheath.
Short/dry installations, eg transformer tails in risers & substation basements	Smooth aluminium sheath with copper or aluminium conductor.
Major tunnels, eg where frequent personnel access is needed, or the risks of fire and multiple cable failures are unacceptable	Cable shall include an additional 3mm layer of low smoke zero halogen material over the normal HDPE oversheath, to retard the spread of fire and smoke.
Submarine cables, eg marine environments where cables are direct-buried or contained in long HDD bores where it may be impossible to easily replace the cable in future	Lead sheath and steel wire armouring.
Contaminated / corrosive / swampy ground	Lead sheath.

**Table 2 – 33kV cables**

Situation	Cable type
Normal feeders, eg in ductline	3c cable to a maximum size of 3c 800mm <sup>2</sup> , where ratings permit.
Cable installation into substation basement	3c cable to a maximum size of 3c 800mm <sup>2</sup> shall be used except where an assessment of the risks has identified this to be an unacceptable solution (in particular due to manual handling issues). In these cases, 1c cables shall be used based on design suitability.
Transformer tails	1c cable.
Major tunnels, submarine & contaminated/corrosive/swampy ground	As 132kV & 66kV cables above.

**Note:** All 33kV cable shall have a polyam sheath and copper screen wires.

### 5.3 Accessories (joints and terminations)

#### 5.3.1 Cable accessories shall:

- Be compatible with the cables being used (note that the specific cable details shall be checked by the accessory supplier to ensure all dimensions are suitable, and for 33kV cables with oxidised strands the connectors are compatible);
- Meet the requirements of Ausgrid's specifications, and;
- Be approved via the process defined in NS181.

**Table 3 – 132kV and 66kV cables**

Situation	Accessory type
Outdoor, eg substation yard or UGOH	Outdoor air-insulated self-supporting termination. A rotating baseplate should be considered for UGOH applications to allow most of the termination works to be carried out at ground level. Outdoor air-insulated non-self-supporting (flexible) terminations are available at 66kV.
SF <sub>6</sub> gas-insulated switchgear	GIS dry-type termination to IEC62271-209 Figure 5. Spare bays on existing switchgear may already have proprietary insulators installed, in this case matching components should be sourced from the insulator supplier if possible, to make the complete GIS termination. If a new insulator is needed, then a complete new GIS termination (including insulator) will be needed. Installation of the new insulator will require works on the internal switchgear components, and the SF <sub>6</sub> gas compartment will need to be degassed / regassed. Unused insulators shall be blanked off using proprietary dummy plugs.
Joint XLPE to XLPE cable	Pre-moulded joint with "heavy duty" outer protection, ie plumbed metal sleeve and compound-filled coffin box. One-piece joints will normally be used where the cables are similar size on each side, and three-piece joints can be used for size changes.
Joint XLPE to oil-filled cable	Oil: XLPE transition joint.

**Table 4 – 33kV cables**

Situation	Accessory type
*Indoor locations within the substation, eg Surry Hills/Willoughby/Merewether	Outdoor air-insulated termination. Terminations may be self-supporting or non self-supporting, depending on busbar arrangement.
*Outdoor, eg substation yard or UGOH	Outdoor air-insulated termination. Terminations may be self-supporting or non self-supporting, depending on busbar arrangement.
*Transformer air-insulated endbox	Outdoor air-insulated non self-supporting termination.
*Transformer plug-in	Separable connector - inner cone or outer cone type, size depends on equipment supplier. Unused insulators shall be blanked off using proprietary dummy plugs.
*Switchgear air-insulated endbox	Indoor air-insulated non self-supporting termination.
*Switchgear plug-in	Separable connector - inner cone or outer cone type, size depends on equipment supplier. Unused insulators shall be blanked off using proprietary dummy plugs.
Joint XLPE to XLPE cable	Pre-moulded, heatshrink or coldshrink joint. Note that 3c/1c, screen continuity and polylam moisture barrier issues need to be considered.
Joint XLPE to HSL/paper-lead cable	HSL (3c) / PILC (1c): XLPE transition joint. Note that 3c/1c, screen continuity and polylam moisture barrier issues need to be considered.
Joint XLPE to gas-filled cable	Gas: XLPE transition joint. Normally 3c gas cable: 1c XLPE cable, max 500mm <sup>2</sup> size.
Splitter kit (3c: 1c cable)	Splitter kits shall be used when terminating three core cables in the situations noted

**Note:** \* The splitter kit shall be installed as close to the terminations as practical, and above ground if possible.

5.4 Link boxes

- 5.4.1 Link boxes shall be fabricated from stainless steel, and shall be watertight and explosion proof to the likely level of pressure that could be developed by an internal flashover or SVL failure.
- 5.4.2 Link boxes and link box pits shall be labelled to Ausgrid's requirements and standard label templates are available on request.
- 5.4.3 Along the cable route, the link boxes are to be installed in suitable concrete link box pits located in the footpath/nature strip adjacent to the cable jointing bay/pit/vault.
- 5.4.4 If footpath/nature strip installation is not practicable then the link box pit shall be installed in the kerbside parking lane.
- 5.4.5 The link box position for double circuit feeder routes shall be consistent at each joint bay to avoid confusion during testing and maintenance (eg Fdr 1 link box is always located on the substation A side, while Fdr 2 link box is always located on the substation B side). Reversing or switching link box relative positions on double circuit joint bays is not acceptable.

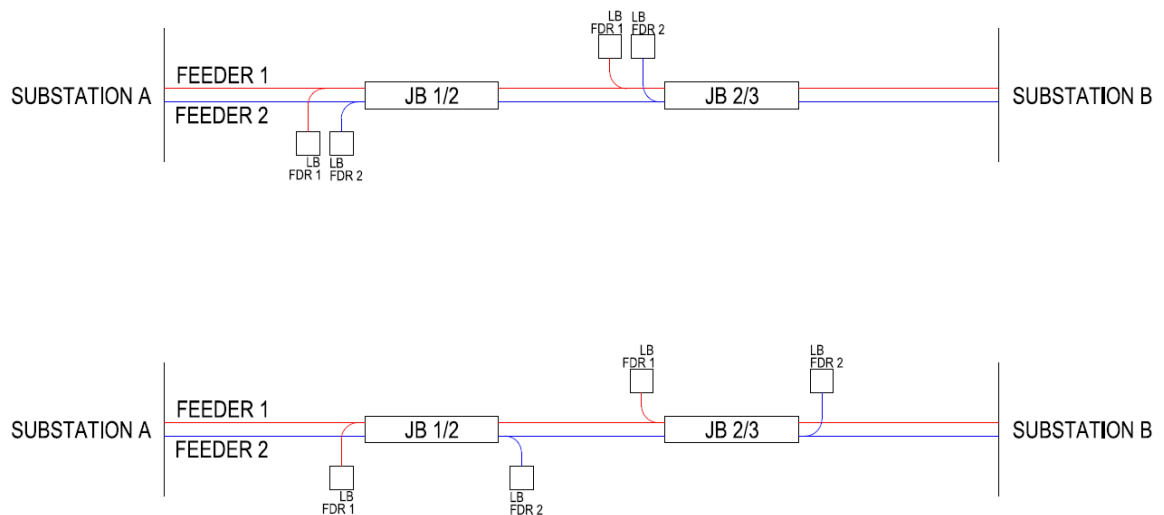
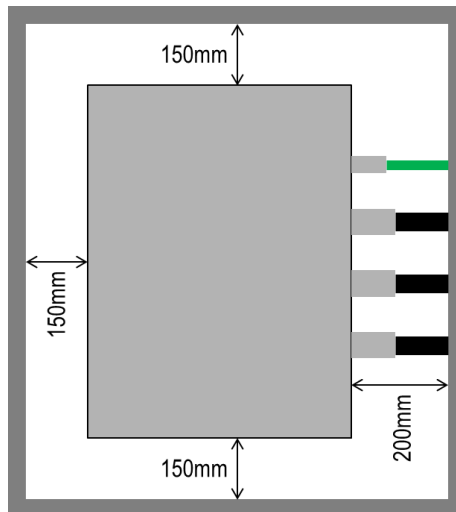

Figure 1 – Example of suitable link box positions for double circuit feeder routes

- 5.4.6 The link boxes shall be securely bolted to the floor of the link box pit to prevent floating and any movement under fault conditions.
- 5.4.7 The internal depth of the link box pit shall be 700 – 900mm to allow easy maintenance.
- 5.4.8 The internal width of the link box pit shall allow a minimum clearance distance of 200mm from the link box on the side of the bonding lead entries and 150mm on the other sides as shown below.



**Figure 2 - minimum clearance between link box and link box pit**

- 5.4.9 Pit access covers shall comply with the Class D watertight requirements of AS 3996.
- 5.4.10 Covers shall be type-tested in accordance with AS 3996 and test certificates made available on application.
- 5.4.11 In addition, covers shall sustain a modified type test, using the ultimate limit state design load, without fracture.
- 5.4.12 The test load shall be applied, without shock, five times, sustaining the test load and zero load alternately for minimum periods of 30 seconds. Any resultant permanent set measured along the unit's long axis shall, after removal of the test load, be not greater than 0.8% of the clear opening span.
- 5.4.13 Pit access cover lifting keyholes shall be provided as per AS 3996 3.2.2.6. The lifting keyhole dimensions in AS 3996 Figure 3.1 and the 35mm (+5, -0mm) distance from the edge of a cover to the centre of a lifting keyhole shall be mandatory rather than "preferred".
- 5.4.14 Covers in footpaths/nature strips shall be installed to open in a safe and accessible direction, ie not over the kerb into the road.
- 5.4.15 Covers in road carriageways shall be installed to be opened in the direction of the traffic lane (ie not across the lanes), and shall open in the traffic direction nominated by the access cover manufacturer - normally in the same direction as the flow of traffic.
- 5.4.16 Link box pit earthing shall meet the requirements of NS260 8.6.

## 5.5 Sheath voltage limiters

- 5.5.1 Sheath voltage limiters (SVLs) at cable terminations or bonding points shall be in accordance with the current Ausgrid specification.
- 5.5.2 The placement of SVLs shall be as specified or approved by the group within Ausgrid responsible for underground sub-transmission mains designs.
- 5.5.3 SVLs generally have a rated discharge current of 20kA and a rated voltage of 4.5kV, 6.0kV, 7.5kV or 9kV as appropriate.

## 5.6 Thermal rating

### 5.6.1 General

5.6.1.1 The required thermal rating and load cycle will be provided in the Development Brief. Inputs into the rating calculations will be:

- Rating types (continuous/cyclic/both feeders in service/single feeder in service).
- Load cycle for cyclic rating.
- Conductor temperature limits.
- Ambient ground temperature.
- Moisture content.
- TSB thermal resistivity: 0.9Km/W.
- Thermal properties of cables and conduits: supplier to provide.

5.6.1.2 Thermal ratings shall be calculated in accordance with IEC60287 and NS272 and shall use the native soil TR values found in the initial route survey.

5.6.1.3 The 50°C isotherm modelling requirements are described in NS272.

5.6.1.4 Backfill materials shall be tested and the test reports submitted to Ausgrid as specified in NS130 and NS130 Annexure L to ensure compliance with TR and quality requirements.

5.6.1.5 Ausgrid shall be consulted about mutual heating effects from parallel/crossing cables.

5.6.1.6 All TR test reports for native soils shall be submitted to Ausgrid no later than six (6) weeks after sampling, who will submit them to [TR and TSB results@ausgrid.com.au](mailto:TR_and_TSB_results@ausgrid.com.au) for incorporation into Ausgrid's ThermalRes database.

### 5.6.2 Distributed temperature sensing (DTS)

5.6.2.1 Distributed Temperature Sensing (DTS) fibre conduits and pits are required on all new sub-transmission feeder installations, with the possible exception of:

- Major tunnel installations where temperature measurements can be carried out more effectively by other methods.
- Short substation routes where there is no possibility of that route being a constraint on the feeder thermal rating.

5.6.2.2 The fibre route shall be designed so that a blowtube can be installed in the DTS conduit within acceptable tension limits, and particular attention should be given to maximising bend radii where the route deviates from the cable trench, eg to fibre pits.

5.6.2.3 The requirements of NS234 "Telecommunications Underground Physical Plant Installation" and NS204 "Communications Pits – Specifications and Installation Guidelines" shall apply.

5.6.2.4 DTS fibre pits shall be located in the footpath wherever possible, and away from power cable jointing bays, pits and vaults.

5.6.2.5 For single core cables installed in trefoil formation, a separate 32mm orange conduit in the centre of the trefoil group where practicable.

- 5.6.2.6 For cables installed in a stacked duct formation, a separate 63mm orange conduit in close proximity to the power cable conduits.
- 5.6.2.7 The conduits shall be mandrel tested and roped, with the ends of the rope left in their respective pits.
- 5.6.2.8 Ausgrid will advise if a DTS fibre and monitoring unit are required, and will provide a specification in these cases.

5.7 **Trench cross-section**

- 5.7.1 Trench cross-sections shall be designed to achieve the required thermal ratings. The dimensions shall take into consideration the cable operating voltage, cable type, and bonding arrangement.
- 5.7.2 Cables shall be installed in conduits using conventional excavation techniques, to minimise community impact during construction and allow easy replacement.
- 5.7.3 Where trenchless techniques are used, the requirements of NS159 will apply.

5.8 **Depth of cables/conduits**

5.8.1 **Classified roads**

To comply with Ausgrid’s Memorandum of Understanding Between Ausgrid and NSW Roads and Maritime Services (RMS) and Transport for NSW August 2011 cables to be installed within State roads shall generally be designed with a minimum cover depth of 1m within the carriageway and 900mm cover outside the carriageway (eg footpath & driveways).

5.8.2 **Non-classified roads**

In Regional and Local (non-classified) road reserves cables shall be designed with a minimum cover depth of 750mm within both the carriageway and non-carriageway areas.

5.8.3 **Extra protection for shallow cables**

Cables may be laid at shallow depths to cross obstructions, subject to an absolute minimum cover depth of 500mm. Steel plate protection shall be installed instead of polymeric cover strips wherever the cover depth is between 500mm and 750mm.

5.8.4 **Special situations - subject to approval**

Where cables run through structures it may be acceptable for the 500mm depth limit to be infringed as long as adequate protection and warnings are provided to control all foreseeable risks during construction and operation of the cables and structure. For example - where a cable runs through a bridge culvert/chase, the cables could be protected by a concrete lid that is clearly marked to show the presence of HV cables (see Figure 3 below) and a stainless steel cover underneath to protect against the impact of mishandling the concrete lid. Another situation where a ductline runs through a carpark structure could require the use of permanent warning signs at 3m intervals to prevent any future drilling or cutting into the ductline. Also see NS130 Annexure J.



Figure 3 - Example of warning sign for bridge installation

Special situations of this type shall include a documented risk assessment, and shall require Ausgrid approval.

5.8.5 **Deep situations**

Rating calculations shall be used to ensure that the required cable ratings are achieved in deep sections, this may require the conduit spacing to be widened or special backfill materials to be used.

5.9 **Trench design**

5.9.1 Cables and conduits shall be backfilled using thermally stable backfill (TSB) as indicated in the following diagrams. The diagrams below show typical / minimum cross sections only - the actual cross section for any particular project will be designed on a case-by-case basis, depending on -

- Voltage, size, type, rating & number of cables;
- Road classification;
- Requirements of local road authority;
- Presence of other services;
- EMF prudent avoidance

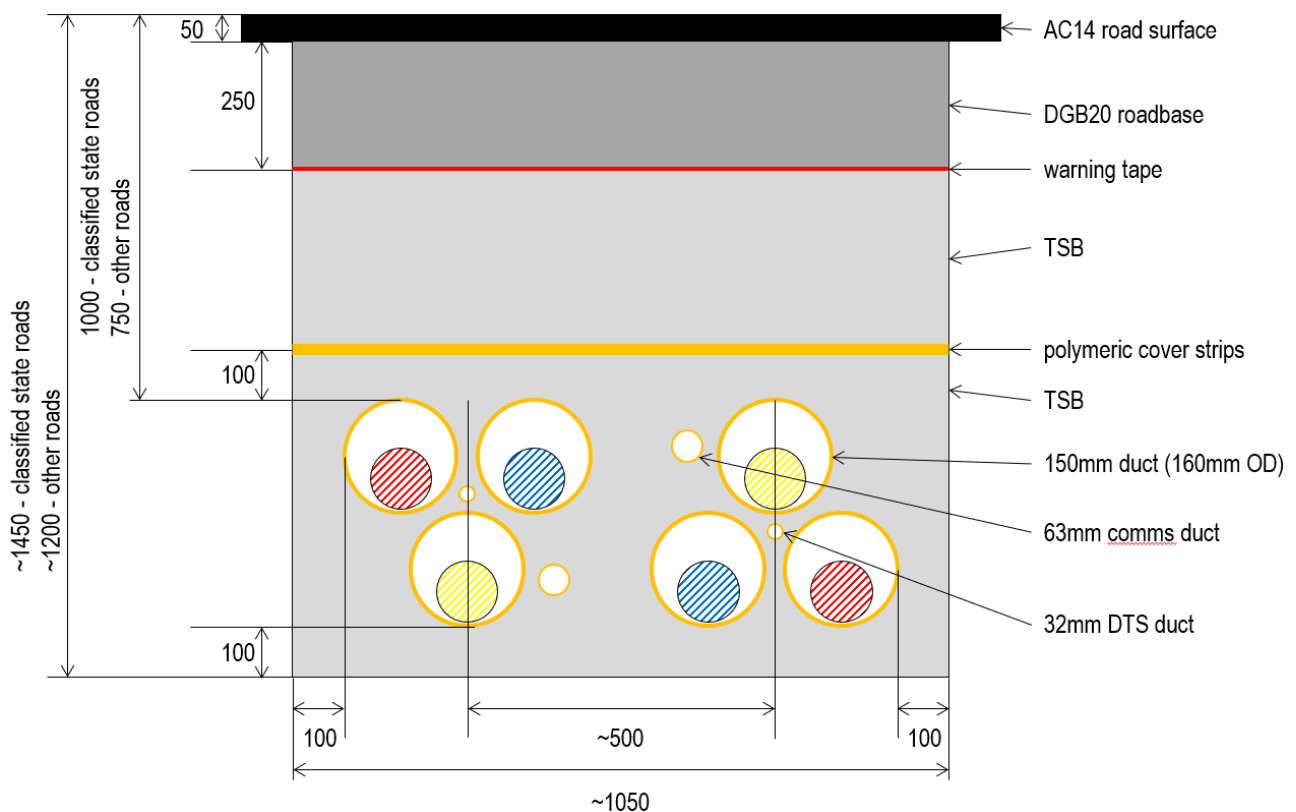

**Figure 4 - Typical trench cross section - double circuit 132kV single core cables using 150mm ducts**

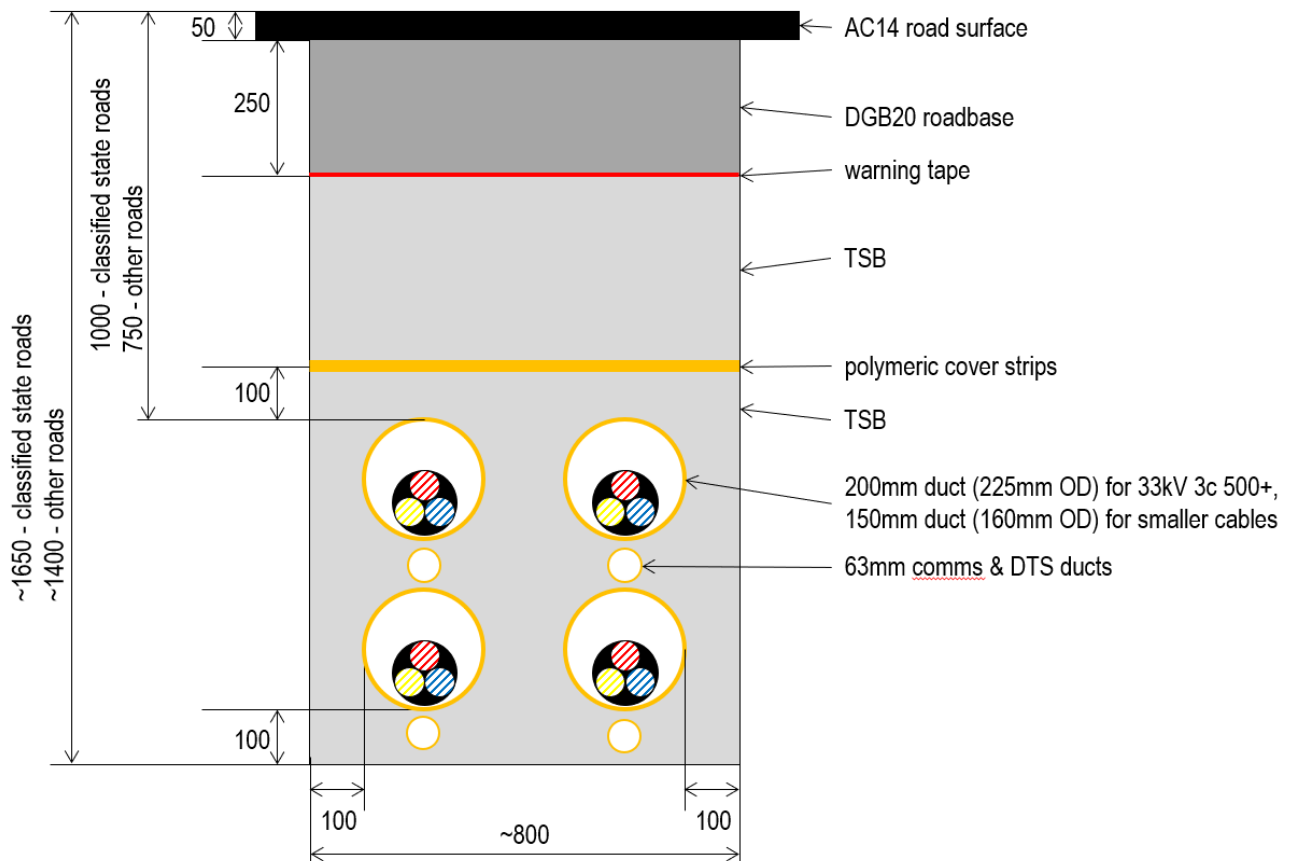

**Figure 5 - Typical trench cross section - four circuit 33kV three core cables**

The following trench design constraints shall be adhered to -

- There shall be a minimum of 100mm of TSB material above, beneath and around the power cables or conduits.
- Polymeric cover strips shall be installed over the entire trench width for mechanical protection 100mm above the top conduit.
- TSB, DGB20 road base or similar backfill material with an appropriate thermal resistivity shall be installed above the polymeric cover strips to the underside of pavement.
- There shall be adequate separation between conduits to allow TSB flow.
- TSB backfill shall meet the requirements of NS130 – note in particular the need for thermal resistivity testing of backfill samples.
- Note that the use of fly ash in TSB incurs various environmental reporting requirements – see NS130 for details.
- Warning tapes shall be installed at the bottom of the road subbase, at a typical cover depth of 300 - 400mm.
- Road restoration shall be carried out to the requirements of the relevant roads authority.

## 5.10 Conduits

Conduits shall be Light Duty UPVC orange conduit in accordance with Ausgrid specification.

**Table 5 – Power cable conduits shall be sized as shown below:**

Conduit nominal size (DN)	Applicable cables
100mm	33kV 1c cables up to 630mm <sup>2</sup> .
150mm	33kV 1c cables 800mm <sup>2</sup> and larger. 33kV 3c cables up to 400mm <sup>2</sup> . 132kV cables with 16mm XLPE insulation & smooth aluminium sheath up to 1600mm <sup>2</sup> .
200mm	33kV 3c cables 500mm <sup>2</sup> and larger. All other 132kV cables.

- 5.10.1 In special circumstances, for example pulling through short lengths of existing conduit, a smaller conduit size may be accepted if approvals are obtained from the group within Ausgrid responsible for underground sub-transmission mains designs.
- 5.10.2 Regardless of initial cable size/type, 200mm conduits may be required in some circumstances, eg to allow for future network construction.
- 5.10.3 Bellmouths shall be required at all locations where conduits end eg joint bays, pulling pits, cable basements.
- 5.10.4 Conduit accessories such as bends, collars and bellmouths, and materials for joining and sealing conduits shall comply with Ausgrid specifications. Conduit bends shall have 6m bend radius.
- 5.10.5 Conduit spacers shall be used for all installations, with conduit separation based on cable rating requirements and to allow TSB to flow as required. The main purpose of the spacers is to keep the conduits in their correct position relative to each other and the surrounding soil, and to prevent them floating as the trench is backfilled. They must be designed so as not to damage the conduits if they soften due to the heat generated by the TSB or concrete as it cures - in particular it is not allowed to use spacers that have been fabricated from round conduit offcuts, as this practice creates a point-to-point contact that is likely to indent the power cable conduit.
- Various spacer types are commercially available.
- 5.10.6 Conduit sizes for telecommunication and DTS cables shall be in accordance with NS234 or as otherwise approved by the group within Ausgrid responsible for telecommunications system design standards.
- 5.11 **Separation from other services and cables**
- 5.11.1 In all cases separations from other services shall be determined in consultation with the other utility.
- 5.11.2 Ausgrid requires a minimum separation of 300mm from other services and cables where practicable, to provide clearance for repairs and to minimise consequent cable derating effects.
- 5.11.3 Refer to SafeWork NSW Guide to Work Near Underground Assets for details of minimum approach distances to various utilities.
- 5.11.4 Additional separation may be required where the cables are to be laid in the vicinity of other power cables or metal pipes. In these cases, following completion of the services search, the rating calculations shall allow for mutual heating from these nearby services and separations calculated to maintain the specified ratings of all circuits.

**Note 1:** Proximity to Telstra or other copper wire telecommunications cables may result in unacceptable voltage rises being induced on the communications cables, either under fault

conditions or if the two circuits run in parallel for a long distance. Separations shall be designed to ensure compliance with the requirements of Telstra or other communications carriers, as specified in:

- Code of Practice for Protection of Personnel and Equipment against Earth Potential Rises Caused by High Voltage Power System Faults. (prepared jointly by the Telecommunications Commission and the ESAA 1984 - covers Earth Potential Rise).
- Mitigation of Hazardous Voltages induced into Telecommunications Lines (Low Frequency Induction Code of Practice 1978 + Application Guide 1984).
- AS/NZS 3835:2006 Earth potential rise – Protection of telecommunications network users, personnel and plant.

**Note 2:** Proximity to metallic pipelines and associated equipment may result in unacceptable voltage rises being induced on the pipelines. Separation distances shall be designed to ensure induced voltages on the pipelines are compliant with the requirements specified in AS/NZS 4853:2012 Electrical Hazards on Metallic Pipelines.

These requirements apply irrespective of whether the other services are installed before or after the sub-transmission cable.

## 5.12 Bonding and earthing

### 5.12.1 General

- 5.12.1.1 The bonding and earthing of any cable will be determined on a case-by-case basis through earthing and rating studies and shall meet the requirements of NS260.
- 5.12.1.2 33kV three core cables shall be solidly bonded to earth at both ends. 33kV & 132kV single core cables will require special bonding and earthing arrangements, as described in NS260 8.8 and below.
- 5.12.1.3 The bonding system shall generally be in accordance with EA ER C55/5 and shall be determined as part of a review of the earthing design of the cable installation and substations at each end of the circuit - including consideration of public safety, transferred potentials and voltages induced onto adjacent equipment/utilities.
- 5.12.1.4 Ausgrid does not specify a limit on the standing sheath voltages, however a maximum of 120V is usually considered appropriate to Ausgrid's network as long as the cable system design, including exposed metal parts, serving, joint barriers, bonding leads, link box and Sheath Voltage Limiters (SVLs), is fit for purpose under both normal and abnormal operating conditions.
- 5.12.1.5 For specially bonded systems, the selection of SVL's shall take into consideration the standing sheath voltage under rated load, the power frequency sheath voltage under fault conditions, the transient over voltages that may be encountered and the level to which these over voltages should be limited.
- 5.12.1.6 Bonding leads shall have stranded copper conductors with a cross sectional area of 300mm<sup>2</sup> for 66kV and 132kV cables, and 185mm<sup>2</sup> for 33kV cables. Concentric bonding leads shall be used at mid-route joint bays to reduce surge impedance. Single core bonding leads shall be used at terminations, normally to single phase link boxes at outdoor terminations and three phase link boxes at GIS terminations. Bonding leads shall be no longer than 10m long to limit surge impedance.
- 5.12.1.7 Any heating effect of circulating sheath currents must be taken into account when calculating the cable's current rating.
- 5.12.1.8 Ausgrid's specifications for bonding lead and ECC cables are available on request.

5.12.2 **Single point bonding**

- 5.12.2.1 In this arrangement the cable sheaths are solidly bonded to earth at one end only.
- 5.12.2.2 The sheath/screen at the other end is isolated from earth potential through a Sheath Voltage Limiter (SVL).
- 5.12.2.3 The SVL provides a high resistance path to earth under normal conditions and a low resistance as sheath voltage increases, thereby protecting the cable's outer sheath and auxiliary components from unacceptably high sheath voltages under transient fault conditions.
- 5.12.2.4 Where single point bonding is used, it will normally be necessary to run one or multiple earth continuity conductors (ECCs), as close as possible to the cables, transposed halfway along the cable section to balance impedances, and connected to the substation, pit or UGOH earthing system at each end. ECCs shall be 185mm<sup>2</sup> or 300mm<sup>2</sup> conductor size, as specified in the earthing design.

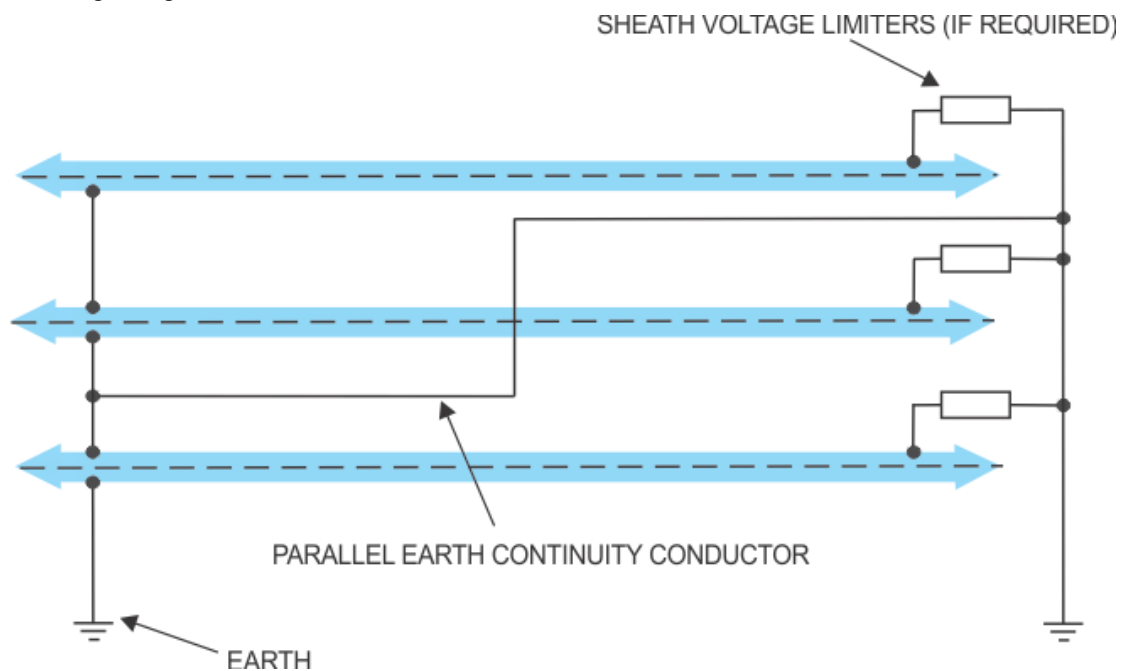

**Figure 6 - Single point bonding**

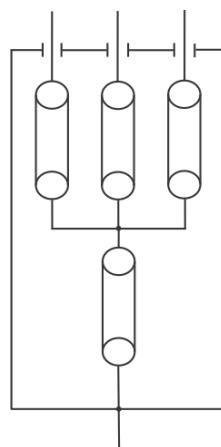

**Figure 7 - Link box without SVLs**

5.12.3 Full cross bonding

- 5.12.3.1 New cross-bonding systems shall use “sectionalised cross bonding” as described in EA ER C55/5.
- 5.12.3.2 The cable sheaths shall be bonded between phases in succession (RàW, WàB and BàR etc.) to cancel out any sheath currents over three minor sections, with SVLs to minimise transient sheath overvoltages.
- 5.12.3.3 The three minor sections will form a major section with earth bonding at each end.
- 5.12.3.4 The lengths and cable configurations shall be designed so that the induced voltages of the three minor sections balance to near-zero, this can be achieved by adopting the same cable configuration in each minor section and joint bay positions being chosen so that the longest minor section length is <5% longer than the shortest minor section length.
- 5.12.3.5 If the imbalance is between 5% and 10% then the design shall be reviewed to ensure that sheath voltages are acceptable and that rating calculations have taken into account the heating effect of circulating sheath currents. Imbalances >10% will also need serious consideration of the effect of circulating currents on bonding leads and link box connections.

**Note:** the example shown below also shows the transposition of single core cables which is required if the cables are installed in a flat configuration. Ausgrid’s preferred configuration for the vast majority of new installations is trefoil in which case transposition is not generally required.

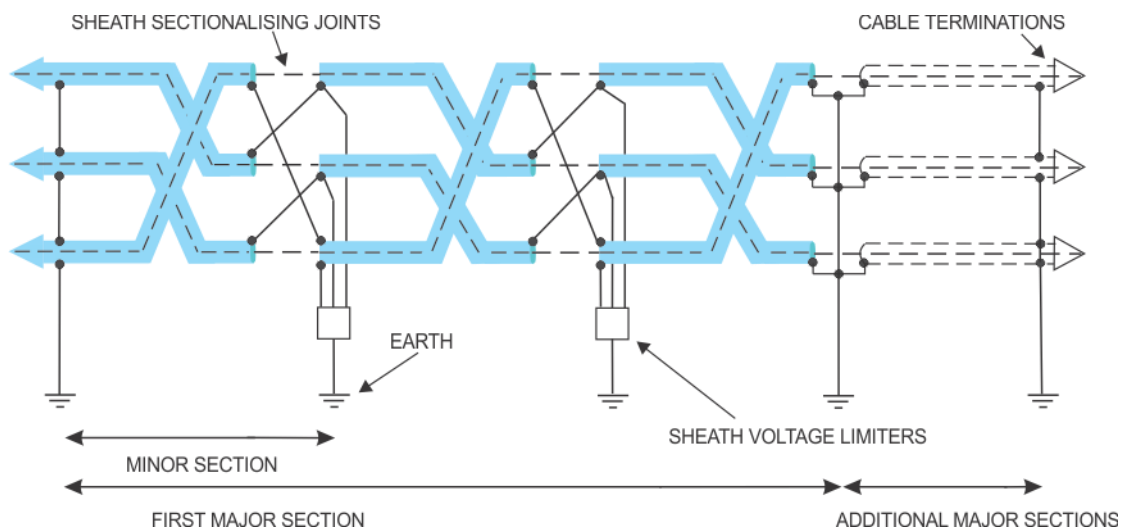

Figure 8 - Cross bonding

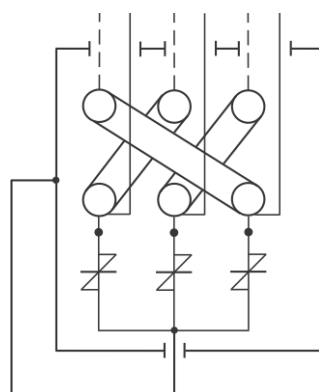

Figure 9 - Cross-bonding link box

#### 5.12.4 Looping existing circuits into new substations

5.12.4.1 From time to time, it is necessary to cut an existing cable and loop it into a new substation.

5.12.4.2 Such actions may significantly impact on the existing earthing and bonding arrangements and thermal ratings, as well as gas pressure or fluid filled circuit design.

5.12.4.3 Where possible the existing design shall be maintained. However, where this is not practicable, the groups within Ausgrid responsible for earthing, cable ratings and transmission mains designs shall provide advice on the basic requirements to be met to comply with system earthing design.

5.12.4.4 This may, for example, involve inserting a single point bonded section (with or without a separate bonding conductor) at the loop in, and a modification to the existing cross bonding arrangements for the rest of the circuit.

#### 5.12.5 Bonding connections at GIS terminations

Special measures need to be taken where CTs are present under 132kV GIS terminations, as all earthing/bonding connections need to be brought down through the CTs to cancel out any sheath currents. Bonding connections for GIS terminations shall meet the requirements of NS260 8.11.

#### 5.13 Joint bays, vaults and pulling pits

5.13.1 Transmission cables shall be jointed in a joint bay which is backfilled after jointing is complete.

5.13.2 The use of jointing vaults may be specified for CBD areas, and these are accessible spaces (not backfilled).

5.13.3 The design requirements for both joint bays and joint vaults are detailed in NS172. Pulling pits may be needed on long/complex sections, so that a caterpillar pulling unit can be used to reduce the maximum cable pulling tension.

#### 5.13.4 Joint bay location

5.13.4.1 Cable section lengths shall be maximised so that a minimum number of joints are needed, consistent with the constraints of the bonding system design.

5.13.4.2 Section lengths shall be a minimum of 500m for 33kV 3c cable, and 700m for other cable types.

5.13.4.3 Pulling tension calculations shall be used to ensure the cables can be successfully installed within the constraints of pulling tensions and sidewall pressures.

5.13.4.4 Joint bays shall be located where they will be readily accessible for future repairs and preferably clear of driveways, intersections and other infrastructure.

5.13.4.5 Joint bays shall not be located in the carriageway of classified roads except with the written approval of the group within Ausgrid responsible for underground sub-transmission mains designs.

5.13.4.6 All joint bay locations shall be investigated by trial hole excavation in order to confirm that the location is suitable for the bay/pit construction intended.

#### 5.13.5 Joint bays for 33kV cables

5.13.5.1 33kV cable jointing shall be carried out in a joint bay that consists of a concrete floor. Concrete walls may be used where shoring, cross-bracing or water ingress causes an unacceptable hindrance to jointing works.

5.13.5.2 The dimensions of joint bays shall be based on the following:

- number of cables,
- distance required to space out cables for jointing,
- length of joints,
- “parking” distance required for jointing components,

- 5.13.5.3 A typical joint bay for three 33kV 3c 500mm<sup>2</sup> XLPE feeders will have internal dimensions of 2m width and 10m length. The maximum joint bay depth, measured from joint bay floor to ground surface level, shall be 2m.
- 5.13.5.4 Joint bays that involve single core cables, special bonding and link boxes will require earthing works to be installed as for 132kV cable joint bays described below.
- 5.13.6 [Joint bays for 132kV and 66kV cables](#)
- 5.13.6.1 132kV and 66kV cable jointing shall be carried out in a joint bay that consists of a concrete floor and walls, either pre-cast or poured in-situ.
- 5.13.6.2 The dimensions of joint bays shall be based on the following:
- number of cables,
  - distance required to space out cables for jointing,
  - length of joints,
  - “parking” distance required for jointing components,
- 5.13.6.3 A typical joint bay for two 132kV 1c 1200mm<sup>2</sup> XLPE feeders will have internal dimensions of 2.8m width and 14m length, with concrete lids to allow the joint bay to be easily closed up between construction, cable pulling, and jointing works. The maximum joint bay depth, measured from joint bay floor to ground surface level, shall be 2m.
- 5.13.6.4 Joint bays that involve special bonding and link boxes will require an earthing design to comply with NS260 section 8.4, this will include multiple earth electrodes and earth bond connections between the joint bay reinforcing bars, link box pit reinforcing bars, link boxes and any ECCs.
- 5.13.7 [Support of cables & joints](#)
- Cables and joints shall be supported and restrained to prevent any movement during operation and future excavations, eg for a fault repair on one feeder. Suitable support systems include; 14:1 sand / cement bags, shaped concrete type blocks, stainless steel posts and cleats as required.
- 5.13.8 [Joint bay backfilling](#)
- 5.13.8.1 Joint bays shall be backfilled with suitable sand to a depth of 100mm above the top of the joints, this sand shall be watered-in around the joints rather than compacted to prevent damage.
- 5.13.8.2 Polymeric cover strips shall be laid over the sand layer across the entire area of the joint bay, and TSB (200-300mm depth) and warning tapes shall then be installed as per the normal trench design.
- 5.13.9 [Pulling pits](#)
- Pulling pits shall be designed with dimensions and floors/walls to suit the pulling equipment being used. Once all cable pulling is complete, split conduits shall be applied to each cable and the pit shall be backfilled in the same manner as joint bays.
- 5.14 [Underground to overhead structures \(UGOHs\)](#)
- 5.14.1 An underground to overhead transition structure (UGOH) shall be required where an underground section of cable connects to an overhead section.
- 5.14.2 Where a section of underground cable is proposed that is near to an existing UGOH structure on the same circuit, Ausgrid may require that the proposed underground cable is extended to the existing cable installation so that a short section of overhead mains and two UGOHs are not required on the network.
- 5.14.3 In the case of tower line terminations, the size and rating of the cables required to match the overhead line rating may require a transition point enclosure that will house cable terminations, surge arresters, station posts and other equipment. Ausgrid will determine the requirements for tower line UGOH transition points on a case by case basis.
- 5.14.4 For tee connections to tower lines and terminations on most pole lines, a pole mounted structure will be suitable.
-

- 5.14.5 A concrete or steel pole shall generally be used for large UGOH structures, eg 132kV & 66kV where the cables' large diameter would hinder future maintenance inspection if a timber pole is used.
- 5.14.6 Timber poles may be used for 33kV UGOHs as long as future maintenance inspections are not compromised, including the provision of a 50mm accessible gap between cable covers in each quadrant of the pole circumference at ground level.
- 5.14.7 Structures made from other materials or that are not a single pole structure will be considered on a case by case basis.
- 5.14.8 Other UGOH designs will be considered by Ausgrid on a case by case basis where none of the constructions above are suitable for a particular application. UGOH designs shall meet the requirements of NS220, NS167 & NS260.
- 5.14.9 Particular attention must be given to the embedment depth and footing design of UGOH poles and structures. Typically, a UGOH pole will be required to support itself and any attached mains with 2-3m of excavation around the pole for the installation of the cable. Therefore, pole embedment calculations must consider the loadings on the pole with this open excavation around the pole.
- 5.14.10 A hard setting pole backfill such as concrete must not be used within the zone where cables are expected to be laid against the pole, but may be used below the level of the proposed cables. For backfilling at the level where cables are fixed to the pole a material should be used that can easily be removed if required without damage to the cable (such as a 20:1 sand cement mix). The thermal resistance value of this material must also be considered.
- 5.14.11 Power cable conduits should be terminated a reasonable distance from the UGOH pole to enable the direct-buried cable to be phased correctly, splayed out, dipped down and bent with the required radius onto the UGOH pole. The distance required will vary based on the size, quantity and voltage of the cable. The use of formed conduit bends to bend the cable up onto a UGOH pole shall be avoided due to the complexities and added tensions involved in pulling the cable through such a system.
- 5.14.12 Cables should preferably be installed on the opposite side of the structure to traffic flow to minimise future risk from vehicle impacts.
- 5.14.13 No other voltages or equipment shall be installed on 132kV & 66kV and large diameter 33kV UGOH structures due to lack of space for attachments & fittings. For 33kV cables 630mm<sup>2</sup> and smaller, lower voltage equipment may be installed on the UGOH structure if adequate space is available.
- 5.15 [Route markers](#)
- 5.15.1 Route markers shall be installed wherever cables are located out of public roads (eg parks, reserves, beaches, river/rail crossings & easements).
- 5.15.2 Route markers are intended to reduce the risk of cable damage by providing a physical indication of the presence of transmission cables in areas where they may not be expected, or where there is an increased risk that a contractor may not take adequate precautions before starting work.
- 5.15.3 Route markers are not intended to be a survey mark to indicate the precise location of cables – a designated underground asset information provider query, cable plans and proper cable location techniques should be used to precisely locate the cables.
- 5.15.4 The location and type of route marker shall be decided in consultation with the landowner, including due consideration of current and planned land usage, in accordance with the following:
- Each marker should be visible from the adjacent markers.
  - Marker separation shall preferably be less than 200m to ensure good visibility, but can be up to 400m if circumstances dictate.
  - A marker should be located at a property boundary where the cable route leaves a public road.
  - A marker should be located where a substantial change of route direction occurs.
-

- Markers should preferably be located along fence lines, rows of trees, property boundaries and similar features.
- Markers shall be easily seen without being obtrusive or interfering with pedestrian/vehicle traffic or posing a risk to public safety.
- Markers shall be located on the route centreline or offset on the edge of the trench if the backfill material makes the centre location impossible.
- Marker posts are preferred as they are easily visible, however marker bricks flush with the ground surface can also be used.
- Water crossings require the use of specific signage, as specified in NS268.

#### 5.15.5 Route marker details:

- Marker post – drawing 42087, stock code 91082.
- Marker brick – drawing 118205-1, stock code H16520.

#### 5.16 Telecommunications

5.16.1 Telecommunications routes must be designed in accordance with the approved telecommunications brief supplied by Ausgrid's Senior Engineer responsible for telecommunications planning.

5.16.2 Pulling calculations for optical fibre cables must be performed in accordance with NS234.

5.16.3 Telecommunications hauling pits must be designed and installed in accordance with NS204.

5.16.4 Route marking in accordance with NS205 must be applied to telecommunications infrastructure which strays away from the HV feeder trench for reasons including but not limited to connection with telecommunications pits or for UGOH transition.

5.16.5 Refer to the Senior Engineer responsible for telecommunications planning for further guidance on route selection.

## 6 Construction

### 6.1 Training requirements

6.1.1 Cable accessories shall be installed by competent personnel who are trained, assessed and deemed competent in the installation of each product family being installed.

6.1.2 The training shall be product family specific, conducted by a training provider who has been approved by the accessory manufacturer, and evidenced by a valid training certificate.

6.1.3 Evidence of the completion of this training must be supplied to Ausgrid prior to commencement of any project. For any questions regarding this requirement please email Electrical Safety & Authorisations at [Level1ASP@ausgrid.com.au](mailto:Level1ASP@ausgrid.com.au).

### 6.2 Hazards from existing underground cables

#### 6.2.1 Oil

6.2.1.1 Ausgrid's existing underground sub-transmission cable system includes approximately 380 route km of oil-filled cables. Oil filled cables are pressurised with insulating oil that is generally a mix of original mineral oil and later synthetic linear alkylbenzene oil that has improved biodegradation characteristics. Due to past damage or leaks the soil surrounding these cables may be contaminated with cable oil, and will need to be appropriately handled and disposed of. Where known these cables will be identified in the Development Brief.

#### 6.2.2 PCB

6.2.2.1 PCB contamination has been found inside some oil-filled cables. Oil testing shall be carried out to identify the presence & concentration of PCBs before works start on oil-filled cables, and appropriate safety controls should be adopted.

### 6.2.3 OCP

6.2.3.1 During the installation of oil-filled cables (pre 1980) the backfill placed around the cables was often saturated with OCPs, usually aldrin and dieldrin, to protect from termite damage. OCPs were also added to the cable sheaths during manufacture of some oil-filled cables. Hence when working on the sheaths of oil-filled cables, or in trenches where oil-filled cables are installed, appropriate handling and disposal precautions must be applied. These precautions may include tests for OCPs and the use of Personal Protective Equipment – see NS156 for further information.

### 6.2.4 Asbestos

6.2.4.1 Asbestos (AC/fibro) conduits were commonly used on Ausgrid's network. If any asbestos is encountered, then safe work method statements and appropriate practices must be implemented. Materials containing asbestos must be handled by a licensed contractor. This material should be disposed to an appropriately licensed landfill.

### 6.2.5 Energised cables

6.2.5.1 Refer to NS156.

6.2.5.2 For work that involves joint bays for existing cables, a risk assessment shall be carried out to control the risks from energised cables and induced/transferred potentials, and it may be necessary to de-energise some or all of the cables during some or all of the work.

6.2.5.3 All cables in an existing joint bay shall be accurately identified and shown clearly on all plans to be used during construction.

### 6.3 Hazards from contaminated land

6.3.1 If part of the route crosses known contaminated land, options to mitigate the potential future safety hazards for staff or impacts to the cables must be considered as part of the design and environmental planning approval. These may include the following:

- Re-route the cables away from the contaminated land.
- Enclose the cable in special fill which provides an impermeable barrier to the contaminants.
- Treat or encapsulate the contaminated soil.
- Design of suitable cable sheaths (eg lead sheath, selected polymers or use of a fluoropolymer layer).
- Special mixes to prevent concrete degradation.

### 6.4 Installation precautions

6.4.1 Temporary steel plates over trenches must have skid resistance comparable with the road. This can be achieved by coating the road plates with a suitable epoxy coating such as "Epirez Supatuff HD", and then applying 0.5 mm (200 –600 micron) quartzite aggregate (QA 2). Prior to applying the antiskid coating, the surface of the road plate must be prepared in accordance with the manufacturer's recommendations. With the road plate in position, a natural taper should be made with asphalt between the road surface and the steel plate to eliminate any sudden level changes that could destabilise a cyclist.

6.4.2 All conduits shall be mandrel tested as per the requirements of NS130, and shall be cleaned shortly before cable pulling to prevent cable damage due to stones/debris.

6.4.3 To avoid cable damage during installation, cable pulling tensions shall generally be restricted to 80% of the cable supplier's nominated maximum pulling tension for the cable and factory-applied pulling eye, and shall ensure that the cable sidewall pressure limit is not infringed. Other constraints include the pull-out strength of pulling eyes in pits or walls of substations, and the rated capacity of the pulling stocking if used.

6.4.4 Pulling tensions shall be monitored by dynamometer during every cable pull, and records of (a) pulling tensions vs distance and (b) time vs distance shall be provided on completion of every cable pull.

6.4.5 Vandalism and attempted theft can lead to substantial cable damage and project delays. Ausgrid's minimum requirements to guard against damage are –

- Cables shall be stored in a secure location before installation.
- Cable drums shall not be left unattended once on site, this includes the provision of a security guard if the cable drum has to be kept on site outside working hours.
- Exposed cables in joint bays, pulling pits etc shall be protected by either covering the excavation with steel plates or concrete lids that are not readily removable by hand, or the provision of a security guard outside working hours.

6.4.6 Water ingress into the joint bay after cable pulling can lead to substantial cable damage and project delays, but can be easily avoided. Water can enter via surface runoff, groundwater seepage and via the incoming conduits. Ausgrid's minimum requirements to guard against water damage are –

- Immediately after each cable pull, the cut end shall be triple-sealed by staff who are specifically trained to carry out this work. Sealing shall be achieved through the use of heat-shrink caps and tubing as shown below. The minimum overlap required between the oversheath of the cable and the cap shall be 75mm, and all shrinkable components must be coated with adhesive sealant.

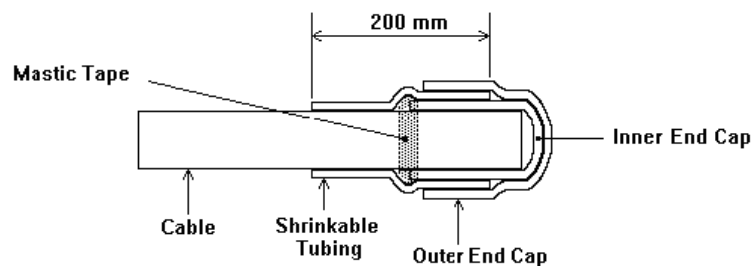

**Figure 10 - Sealed cable**

- It is acceptable to leave the original pulling eye on the other end of the cable for a period up to 3 months, providing that the pulling eye is adequately rated and tested against water ingress and that no significant damage has occurred to the waterproofing components during pulling.
- All cable ends shall be raised and supported to the maximum possible level in the joint bay to minimise exposure to high water levels in the period before jointing starts.
- The joint bay shall be kept clear of incoming water from the time that the first cable sealed end is removed for jointing until all joints are effectively waterproof. Precautions shall include having a pump, generator and water storage capacity available on site, and adequate staff and inspections to ensure that water is pumped out at all times including nights, weekends and public holidays. Particular attention should be given to weather forecasts as severe storms can cause large sudden volumes of runoff, and the joint bay shall be surrounded with suitable runoff protection, eg coldmix berm around the joint bay, and pipes to maintain gutter flow past the joint bay.

## 6.5 Field recording of network assets

Information regarding the construction, modification, repair, and/or retirement of Ausgrid's network assets must be recorded in accordance with NS100 - Field Recording of Network Assets. These records must be submitted to the Data Maintenance team in accordance with NS100.

## **7 Final Project Documentation**

7.1 On completion of construction, the following information shall be provided to Ausgrid as an Operations and Maintenance Manual:

- Route plan.
- Bonding schematic.
- Rating calculations.
- ITPs for cables, including sample & routine factory test reports and cable site test reports (eg serving tests).
- ITPs for cable accessories, including routine factory test reports, serial numbers, jointing instructions, drawings and jointer checklists.
- ITPs for cable pulling, including pulling tension values.
- Final as-built construction drawings, including layout & structural drawings for each joint bay.
- Soil test reports, including thermal & electrical resistivity.
- TSB backfill test reports, including thermal resistivity.

7.2 All drawings shall be provided in the format required by NS104.

7.3 Upon receipt of the Operations and Maintenance Manual the Ausgrid officer shall arrange for the final as-built drawings to be registered into Ausgrid's Drawing Management System (Vault) and the Operations and Maintenance Manual to be stored on Ausgrid's Intranet site.

## Annexure A: List of drawings

Users must ensure that the drawings they are using are the current versions with all amendments.

**Table A1 - Standard sub-transmission UGOH drawings**

Drawing Number	Drawing Description
<b>166244</b>	Standard Construction 33kV UGOH on Concrete Poles 630mm <sup>2</sup> – 1200mm <sup>2</sup> General Arrangement (self-supporting sealing ends)
<b>192881</b>	Standard Construction 66kV UGOH on Concrete Pole General Arrangement
<b>221816</b>	Standard Construction 132kV Transmission Line UGOH Termination Arrangement
<b>227403</b>	Standard Construction 33kV UGOH for 3 Core Cable Flexible Terminations General Arrangement
<b>229262</b>	Standard Construction 33kV UGOH for Concrete Pole 300mm <sup>2</sup> – 1600mm <sup>2</sup> Twin Cables per Phase Screen Earthed Assembly General Arrangement (uses flexible terminations)
<b>232985</b>	Standard Construction 33kV UGOH on Concrete Pole 300mm <sup>2</sup> – 1600mm <sup>2</sup> General Arrangement (uses flexible terminations)
<b>238370</b>	Standard Construction 33kV UGOH on Timber Poles General Arrangement
<b>221569</b>	Standard Construction 66kV UGOH on Concrete Pole 300mm <sup>2</sup> to 800mm <sup>2</sup> – Twin Cables per Phase General Arrangement

**Table A2 - General drawings**

Drawing Number	Drawing Description
<b>42087</b>	Cable Routes - Concrete Marker Post Details
<b>118205</b>	Substations Underground Cables Switchyard Cable Marker
<b>202565 -1</b>	Standard Construction Guidelines for Installation of Metal Reinforcing in Footing, Concrete Walls & Cable Support Steelwork

## Annexure B: Kooragang Island Design Requirements

### Purpose

Annexure B defines special requirements for new cable connections to the Kooragang Island 33kV distribution network, specifically the use of single core cables into kiosk switchgear.

The requirements of each clause in Annexure B shall substitute for the corresponding clause in the main document (for example the requirements of Clause B.5.2 shall apply in place of Clause 5.2), and all other requirements of the main document shall still apply.

Clause numbering below reflects that of the main body of NS168:

### B.5.2 Cable type

New cable installations shall use cables with copper conductor and XLPE insulation.

**Table B1 – 33kV cable type**

Situation	Cable type
Connection from existing overhead line or underground cable	1c cable (up to 300mm <sup>2</sup> )

**Note:** All 33kV cables shall have a polylam sheath and copper screen wires rated at 25kA.

### B.5.3 Accessories (joints and terminations)

Cable accessories shall:

- Be compatible with the cables being used (note that the specific cable details shall be checked by the accessory supplier to ensure all dimensions are suitable);
- Meet the requirements of Ausgrid's specifications, and;
- Be approved via the process defined in NS181.

**Table B2 – 33kV cable accessories**

Situation	Accessory Type
Outdoor, eg substation yard or UGOH	Outdoor air-insulated termination. Terminations may be self-supporting or non- self-supporting, depending on the arrangement.
Kiosk switchgear	Separable connector - outer cone type. Unused insulators shall be blanked off using compatible dummy plugs
Joint XLPE to XLPE cable	Pre-moulded, heatshrink or coldshrink joint. Note that 3c/1c, screen continuity and polylam moisture barrier issues need to be addressed.
Joint XLPE to HSL/paper-lead	HSL (3c) / PILC (1c): XLPE transition joint. Note that 3c/1c, screen continuity and polylam moisture barrier issues need to be addressed.

### B.5.8 Depth of cables/conduits

The depth of cover of cables and conduits shall comply with NS130 Clause 10.11 Standard depth of cover and NS130 Clause 10.12 Reduced depth of cover.

### B.5.9 Trench design

The typical trench cross section for single circuit 33kV single core cables is shown in Figure B1.

All other trench design requirements are as NS168 Clause 5.9.

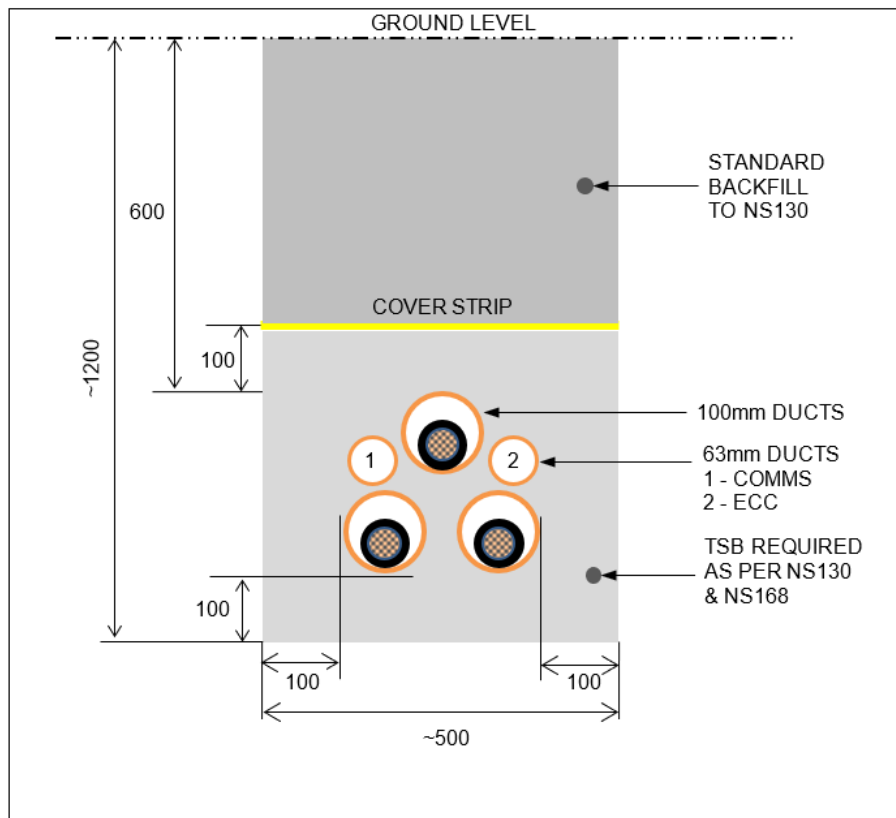

Figure B1: Typical trench cross section – single circuit 33kV supplying kiosk substation

### B.5.10 Conduits

Power cable conduits shall be sized as shown below:

Table B3 – Conduit sizes

Conduit nominal size (DN)	Applicable cables
100mm	33kV 1c cables up to 630mm <sup>2</sup>
150mm	33kV 1c cables 800mm <sup>2</sup> and larger

All other conduit requirements are as NS168 Clause 5.10.

**B.1.12 Bonding and earthing**

Management of earthing risks shall be in accordance with NS116 and NS260.

**Connections to existing overhead lines:**

Cable screens shall be single point bonded. An earth continuity conductor (ECC) shall be installed with single point bonded cables, with the bonding configuration of the ECC at the UGOH determined as part of the earthing design for the kiosk.

**Connections to existing underground cables:**

Cable screens shall be solidly bonded. At kiosk end, the cable screen shall be solidly bonded to the earth bar via the screen of the separable connector at the switchgear. At the joint to the existing cable, the cable screen shall be connected to the screen of the existing cable.

All other bonding and requirements are as NS168 Clause 5.12.

### **Annexure C: Installation of Sub-transmission Cables and Fibre Optic Cables in Private Buildings**

Installation of sub-transmission cables and fibre optic cables in private buildings annexure is stored externally to this standard.