

Network Standard

NETWORK	Document No	: NW000-S0133
	Amendment No	: 1
	Approved By	: Manager – T & DME
	Approval Date	: 06/06/2017

Minor amendments approved – 20.02.2018

NW000-S0133

NS268 SPECIFICATION FOR DESIGN AND CONSTRUCTION OF WATERWAY CROSSINGS



ISSUE

For issue to all Ausgrid and Accredited Service Providers' staff involved with the design and construction of waterway crossings and is for reference by field, technical and engineering staff.

Ausgrid maintains a copy of this and other Network Standards together with updates and amendments on www.ausgrid.com.au.

Where this standard is issued as a controlled document replacing an earlier edition, remove and destroy the superseded document.

DISCLAIMER

As Ausgrid's standards are subject to ongoing review, the information contained in this document may be amended by Ausgrid at any time. It is possible that conflict may exist between standard documents. In this event, the most recent standard shall prevail.

This document has been developed using information available from field and other sources and is suitable for most situations encountered in Ausgrid. Particular conditions, projects or localities may require special or different practices. It is the responsibility of the local manager, supervisor, assured quality contractor and the individuals involved to make sure that a safe system of work is employed and that statutory requirements are met.

Ausgrid disclaims any and all liability to any person or persons for any procedure, process or any other thing done or not done, as a result of this Standard.

All design work, and the associated supply of materials and equipment, must be undertaken in accordance with and consideration of relevant legislative and regulatory requirements, latest revision of Ausgrid's Network Standards and specifications and Australian Standards. Designs submitted shall be declared as fit for purpose. Where the designer wishes to include a variation to a network standard or an alternative material or equipment to that currently approved the designer must obtain authorisation from the Network Standard owner before incorporating a variation to a Network Standard in a design.

External designers including those authorised as Accredited Service Providers will seek approval through the approved process as outlined in NS181 Approval of Materials and Equipment and Network Standard Variations. Seeking approval will ensure Network Standards are appropriately updated and that a consistent interpretation of the legislative framework is employed.

Notes: 1. Compliance with this Network Standard does not automatically satisfy the requirements of a Designer Safety Report. The designer must comply with the provisions of the Workplace Health and Safety Regulation 2011 (NSW - Part 6.2 Duties of designer of structure and person who commissions construction work) which requires the designer to provide a written safety report to the person who commissioned the design. This report must be provided to Ausgrid in all instances, including where the design was commissioned by or on behalf of a person who proposes to connect premises to Ausgrid's network, and will form part of the Designer Safety Report which must also be presented to Ausgrid. Further information is provided in Network Standard (NS) 212 Integrated Support Requirements for Ausgrid Network Assets.

2. Where the procedural requirements of this document conflict with contestable project procedures, the contestable project procedures shall take precedent for the whole project or part thereof which is classified as contestable. Any external contact with Ausgrid for contestable works projects is to be made via the Ausgrid officer responsible for facilitating the contestable project. The Contestable Ausgrid officer will liaise with Ausgrid internal departments and specialists as necessary to fulfil the requirements of this standard. All other technical aspects of this document which are not procedural in nature shall apply to contestable works projects.

INTERPRETATION

In the event that any user of this Standard considers that any of its provisions is uncertain, ambiguous or otherwise in need of interpretation, the user should request Ausgrid to clarify the provision. Ausgrid's interpretation shall then apply as though it was included in the Standard, and is final and binding. No correspondence will be entered into with any person disputing the meaning of the provision published in the Standard or the accuracy of Ausgrid's interpretation.

KEYPOINTS

This standard has a summary of content labelled "KEYPOINTS FOR THIS STANDARD". The inclusion or omission of items in this summary does not signify any specific importance or criticality to the items described. It is meant to simply provide the reader with a quick assessment of some of the major issues addressed by the standard. To fully appreciate the content and the requirements of the standard it must be read in its entirety.

AMENDMENTS TO THIS STANDARD

Where there are changes to this standard from the previously approved version, any previous shading is removed and the newly affected paragraphs are shaded with a grey background. Where the document changes exceed 25% of the document content, any grey background in the document is to be removed and the following words should be shown below the title block on the right hand side of the page in bold and italic, for example, Supersedes – document details (for example, "Supersedes Document Type (Category) Document No. Amendment No.>").

Network Standard NS 268 Specification for Design and Construction of Waterway Crossings

Contents

1.0	PURPOSE	6
2.0	SCOPE	6
3.0	REFERENCES	6
3.1	General.....	6
3.2	Ausgrid documents	6
3.3	Other standards and documents.....	7
3.4	Acts and regulations.....	7
4.0	DEFINITIONS	7
5.0	DESIGN AND CONSTRUCTION	9
5.1	General.....	9
5.2	Approvals	9
5.3	Risk assessment	10
5.3.1	General.....	10
5.3.2	Process	10
5.3.3	Key information arising from risk assessment	10
5.4	Preparation of detail design plans and construction	13
5.5	Post-construction survey and maximum sag calculation	13
5.5.1	Overhead crossings	13
5.5.2	Submarine crossings.....	14
6.0	SERVICE MAINS.....	14
7.0	PRIVATE CROSSINGS.....	14
8.0	WARNING SIGNS	15
8.1	General.....	15
8.2	Signage for multiple adjacent crossings	15
8.3	Signage design requirements	15
8.3.1	General.....	15
8.3.2	Overhead crossing signage design requirements.....	16
8.4	Supplementary flooding signs.....	17
8.5	Alteration of signage	17
9.0	DOCUMENTATION	17
9.1	Risk assessment	17
9.2	Design drawings.....	18
9.3	Survey drawings.....	18
9.4	GIS	18
10.0	RECORDKEEPING	19
11.0	AUTHORITIES AND RESPONSIBILITIES	19
12.0	DOCUMENT CONTROL.....	19
	ANNEXURE A –SAMPLE COMPLIANCE CHECKLIST	20

ANNEXURE B – OVERHEAD WATERWAY CROSSING SURVEY SPECIFICATION 22

 B1 General..... 22

 B2 Provision of information by Ausgrid 22

 B3 Survey requirements 22

 B4 Survey accuracy..... 23

 B5 Methodology..... 23

 B6 Pole identification 23

 B7 Catenary observations and points of attachment 23

 B8 Edge of waterway and location 25

 B9 Ground profile 26

 B10 Detail survey 26

 B11 Tidal or water level planes 26

 B12 Photographs..... 26

 B13 Survey searches 27

 B14 Boundary definition 27

 B15 Existing services 27

 B16 Presentation of data 27

 B17 Ausgrid survey code/layer codelist 28

 B18 Waterway crossing survey requirements 30

 B19 Attachment point photos 31

ANNEXURE C – TYPICAL WATERWAY CROSSING SPAN DESIGN DRAWING 36

ANNEXURE D – LIST OF DRAWINGS..... 37

1.0 PURPOSE

To define the minimum requirements for designing and constructing waterway crossings over navigable waters, in accordance with the Crossings of NSW Navigable Waters: Electricity Industry Code and Australian Standard AS 6947 – Crossing of Waterways by Electricity Infrastructure.

2.0 SCOPE

This document is intended to assist Ausgrid employees and ASPs involved in the design and construction of Ausgrid overhead, under-bored and submarine waterway crossings including 132kV, 66kV, 33kV, 22kV, 11kV, LV and communications cables. This document should be used in conjunction with T0070 which defines Ausgrid's requirements regarding the ongoing management of waterway crossings over navigable waters.

3.0 REFERENCES

3.1 General

All work covered in this document shall conform to all relevant Legislation, Standards, Codes of Practice and Network Standards. Current Network Standards are available on Ausgrid's Internet site at www.ausgrid.com.au.

3.2 Ausgrid documents

- Bushfire Risk Management Plan
- Company Form (Governance) - Network Technical Document Endorsement and Approval
- Company Procedure (Governance) - Network Technical Document Endorsement and Approval
- Company Procedure (Network) – Network Standards Compliance
- Company Procedure (Network) - Production / Review of Network Standards
- Customer Installation Safety Plan
- Electrical Safety Rules
- Electricity Network Safety Management System Manual
- NS125 Construction of Low Voltage Overhead Mains
- NS126 Construction of High Voltage Overhead Mains
- NS130 Specification for Laying Underground Cables up to and Including 11kV
- NS135 Construction of Overhead Sub-transmission Lines
- NS159 Installation of Cables and Conduits using Trenchless Technologies
- NS168 Specification for the Design and Construction of 33kV, 66kV and 132kV Underground Cables
- NS181 Approval of Materials and Equipment and Network Standard Variations
- NS212 Integrated Support Requirements for Ausgrid Network Assets
- NS220 Overhead Design Manual
- Public Electrical Safety Awareness Plan
- T0070 Management of Waterway Crossings
- Tree Safety Management Plan.

3.3 Other standards and documents

- ENA Doc 001-2008 National Electricity Network Safety Code
- AS 6947 – Crossing of Waterways by Electricity Infrastructure
- Crossings of NSW Navigable Waters: Electricity Industry Code
- Networks NSW Vegetation Management Common Requirement Ausgrid/Endeavour Energy/Essential Energy
- NSW Service and Installation Rules
- Protocol for Incident Reporting and Analysis
- Protocol for Exchange of GIS Data on Crossings of NSW Navigable Waters.

3.4 Acts and regulations

- Electricity Supply (General) Regulation 2014 (NSW)
- Electricity Supply (Safety and Network Management) Regulation 2014
- Work Health and Safety Act 2011 and Regulation 2011.

4.0 DEFINITIONS

Accredited Service Provider (ASP)	An individual or entity accredited by the NSW Department of Planning and Environment, Energy, Water and Portfolio Strategy Division, in accordance with the Electricity Supply (Safety and Network Management) Regulation 2014 (NSW).
AHD	Australian Height Datum - the datum adopted by the National Mapping Council as the datum to which all vertical control for land based mapping is to be referred.
Business Management System (BMS)	An Ausgrid internal integrated policy and procedure framework that contains the approved version of documents.
Crossing	Any cable, wire or similar electricity infrastructure that crosses a navigable waterway, either overhead, under-bored or submarine, that may or may not include associated supporting structures.
Design height	The minimum height of an overhead crossing above the AHD with the conductor at maximum sag under all conditions.
Designer	An Ausgrid employee, contractor to Ausgrid or ASP/3 who is duly qualified to produce design plans
Document control	As a minimum requirement, controlled documents will be identified by a unique number, be signed or noted as approved by the appropriate approving officer, have the current amendment number and approval date clearly displayed. Note: Ausgrid employees who work with printed copies of document must check the Business Management System (BMS) regularly to monitor version control. Documents are considered “uncontrolled if printed”, as indicated in the footer
HAT	Highest Astronomical Tide – the highest tide level based on any combination of astronomical conditions and average meteorological conditions. (Note: HAT is not the highest water level which can be reached, as storm surges, etc may cause considerably higher to occur). Note: HAT relates to tidal waterways; for non-tidal waterways the highest water level (generally relative to AHD) needs to be determined.

LAT	Lowest Astronomical Tide – the lowest tide level based on any combination of astronomical conditions and average meteorological conditions (LAT is approximately the same distance below AHD as HAT is above AHD ie $LAT \approx - (HAT)$).
Maximum Vessel Height	The maximum height of a vessel, above waterline, which can be reasonably expected to navigate in the vicinity of the crossing.
Navigable waterway	Waterways which have been mapped by NSW Roads and Maritime Services for the purposes of the Code.
Network Standard	A document, including Network Planning Standards, that describes Ausgrid's minimum requirements for planning, design, construction, maintenance, technical specification, environmental, property and metering activities on the distribution and transmission network. These documents are stored in the Network Category of the BMS repository..
Recordkeeping	Making and maintaining complete, accurate and reliable evidence of business transactions in the form of recorded information (Source: AS Records classification handbook – HB5031 – 2011).
Review date	The review date displayed in the header of the document is the future date for review of a document which is one year for documents requiring annual review, two years for fraud control documents or the default period of three years from the date of approval. A review may be mandated at any time where a need is identified due to changes in legislation, organisational changes, restructures, occurrence of an incident or changes in technology or work practice.
RMS	NSW Roads and Maritime Services
SAP	Ausgrid's internal asset database that stores the information and inspection/maintenance history of all Ausgrid overhead line supports, pillars and other network assets.
Service mains	Overhead conductors, or under-bored or submarine cables, operating at not more than 600/1000V, between the electricity distribution system and the customers connection point. Once installed the service mains come under the ownership, control and maintenance of Ausgrid as part of its network.
Submarine crossing	Includes both trenched and direct laid cables. Cables installed by trenchless (under-boring, horizontal directional drilling) techniques are not included as they should not have any adverse impact on navigation safety.
The Code	Crossings of NSW Navigable Waters: Electricity Industry Code
Vessel	Watercraft of any description used or capable of being used as a means of transportation on water. It includes any non-displacement craft and seaplanes whilst on the water.

5.0 DESIGN AND CONSTRUCTION

5.1 General

Waterway crossings across navigable waters which fall under the jurisdiction of NSW Roads and Maritime Services (RMS) are to be designed and constructed in accordance AS 6947 and the Crossings of NSW Navigable Waters: Electricity Industry Code (the Code).

Live overhead mains and submarine cables which cross navigable waterways can pose a hazard to navigation. Serious accidents, injury and deaths can occur when a vessel comes into contact with such live electricity infrastructure. The design of each crossing must be based on a risk assessment so that all risks associated with the proposed crossing are identified and appropriately addressed such that the residual risk is "Low" or at least as low as reasonably practicable (ALARP). For each crossing this risk assessment must be reviewed every time anything that could affect the residual risk is altered, especially the height of an overhead crossing.

Any proposal to construct any new, redesigned, reconstructed or relocated crossing must be approved by Ausgrid Primary Systems prior to the commencement of any design or construction work. Work on any crossing that is deemed contestable must comply with appropriate Connection/Relocation Policies and follow the Contestable process.

The design and construction of a crossing consists of the following basic sequential elements:

- approvals,
- risk assessment,
 - site visit and investigation,
 - for overhead crossings: calculation of required minimum conductor height,
 - for submarine and under-bored crossings: acceptable installation method (eg: under-bore, trenched/buried in bed of waterway, direct laid on top of bed of waterway),
- preparation of detailed design plans and construction,
- post-construction survey of crossing to confirm construction is in accordance with the design including conductor height(s), cable route, etc as appropriate.

5.2 Approvals

It is the Designer's responsibility to obtain all approvals which may be required from various agencies including but not limited to:

- Roads and Maritime Services (RMS),
- NSW Department of Primary Industries - Lands, and
- local councils.

Roads and Maritime Services is the "landowner" of Sydney Harbour and its tributaries, Botany Bay, Newcastle Harbour and Port Kembla Harbour. Where a crossing is proposed for these waterways Roads and Maritime Services must be contacted to establish whether it consents to the use of the waterway for the purpose of the crossing. If such consent is given, it may be necessary to obtain an easement from Roads and Maritime Services. This includes where cables are installed by trenchless technologies. Where excavation or filling activities are planned it may also be necessary to obtain the permission of Roads and Maritime Services, under Section 13TA Erosion or Siltation in Certain Ports of the Maritime Services Act 1935 (NSW), before work can begin.

The beds of most tidal waters (including oceans and rivers) and many of the beds of non-tidal waters (including rivers, streams and lakes) comprise Crown land and are managed by NSW Department of Primary Industries - Lands. Over time the physical water boundaries may change position by natural processes such as erosion or accretion (Doctrine of Accretion). The current land title depicting these boundaries may not necessarily reflect the location of the boundary as it is today. Local councils and other consent authorities may require a development application.

5.3 Risk assessment

5.3.1 General

For each crossing a risk assessment is to be prepared. This is necessary so that all risks associated with the crossing are identified and that appropriate measures can be included in the design stage to mitigate those risks. Risk assessments shall be prepared in a consistent manner in accordance with Ausgrid Network Engineering Guideline NEG OH14.

5.3.2 Process

The process to prepare a waterway crossing risk assessment is as follows:

1. For non-contestable works:
 - a. The preparation of all waterway crossing risk assessments shall be the responsibility of the Mains Design Manager, Major Project Services in consultation with the Transmission and Distribution Mains Manager, Primary Systems. Risk assessments shall be approved by the relevant Level 5 Asset Management Division manager.
2. For contestable works:
 - a. The customer/ASP3 will be responsible for arranging for the preparation of the waterway crossing risk assessment. Ausgrid will make available a copy of NEG OH14 and an example risk assessments for this purpose.
 - b. The customer/ASP3 submits the risk assessment to Ausgrid for certification. Australian Energy Regulator (AER) rates apply and must be paid for this certification.
 - c. The Ausgrid Contestable Connections officer will arrange for the risk assessment to be certified through the relevant Ausgrid Level 5 Asset Management Division manager.
3. The designer investigates options and prepares a waterway crossing design in accordance with the risk assessment. The design must provide for a crossing which is inherently "Low" risk.

Note: The risk assessment shall be prepared and submitted to Ausgrid in Microsoft Word format and Ausgrid requests that at the time the risk assessment is provided, Ausgrid is granted a perpetual, unrestricted, non-exclusive, irrevocable, royalty-free, transferable licence to use and exercise in its sole discretion the risk assessment for any purpose related to Ausgrid's distribution network.

5.3.3 Key information arising from risk assessment

5.3.3.1 Overhead crossings

Key information arising from the risk assessment will include information that may impact on the height of any proposed overhead crossing including but not limited to:

- the height of the highest vessel that is likely to use the waterway in the vicinity of the crossing,
- the maximum wave height at the location (which is different for each location and dependant on nature of waterway ie wind, ocean swell, etc),
- the minimum required design height above HAT (or highest water level) at maximum conductor operating temperature:
 - the maximum vessel height to be shown on the associated signage, and
 - the size, location and orientation of required signage.

Note: Where the determining factor affecting the maximum height of vessels using a waterway is the clearance beneath a bridge (or other structure), consideration should be given to using the height of the under-side of the bridge above Lowest Astronomical Tide (LAT) at the bridge as the height of the highest vessel (H_{vessel}).

Table 1 – Design Height of New Crossing

The design height of a new crossing is to be such that:

$$H_{\text{crossing}} \geq H_{\text{vessel}} + S + E + W + \text{SCF}$$

where:

H _{crossing}	=	Minimum height of crossing conductors above HAT (or highest water level ¹) at maximum operating temperature.	
H _{vessel}	=	Height of highest vessel known to use the waterway (as determined during the site visit and investigation) rounded up to the next whole metre	
S	=	Safety margin (= 2.2m in all cases)	
E	=	Electrical clearance	= 0.3m for voltage ≤ 33kV (including communications cables)
			= 0.8m for 33kV > voltage ≤ 132kV
W	=	Allowance for wave height (as determined during the site visit and investigation)	
SCF	=	Sag Compensation Factor = a factor that will allow for such things as: <ul style="list-style-type: none"> • construction inaccuracy, • survey inaccuracy, • pole movement, • conductor creep and • the fact that the crossing will be subsequently surveyed and assumed to be at ambient temperature when in reality it may be at a higher temperature. The SCF will be determined by the Designer to suit the particular situation.	
Notes:			
1) For tidal waterways the crossing is to be designed so that the conductors achieve the minimum height above HAT. For non-tidal waterways the highest water level will need to be determined and the crossing is to be designed so that the conductors achieve the minimum height above this level which is generally relative to AHD rather than HAT.			

Note: the maximum vessel height is to be rounded UP to the next whole metre and this affects the design height.

For example: if a new 11kV crossing is to be constructed, and investigation reveals that:

- highest vessel to use the waterway is 10.4m and
- maximum wave height on the waterway at the proposed crossing location is 0.5m,

The crossing must be designed for a vessel height of 11m (= 10.4m rounded up to next whole metre).

The minimum height to which the crossing must be designed and constructed = 11 + 2.2 + 0.3 + 0.5 = 14.0m PLUS SCF.

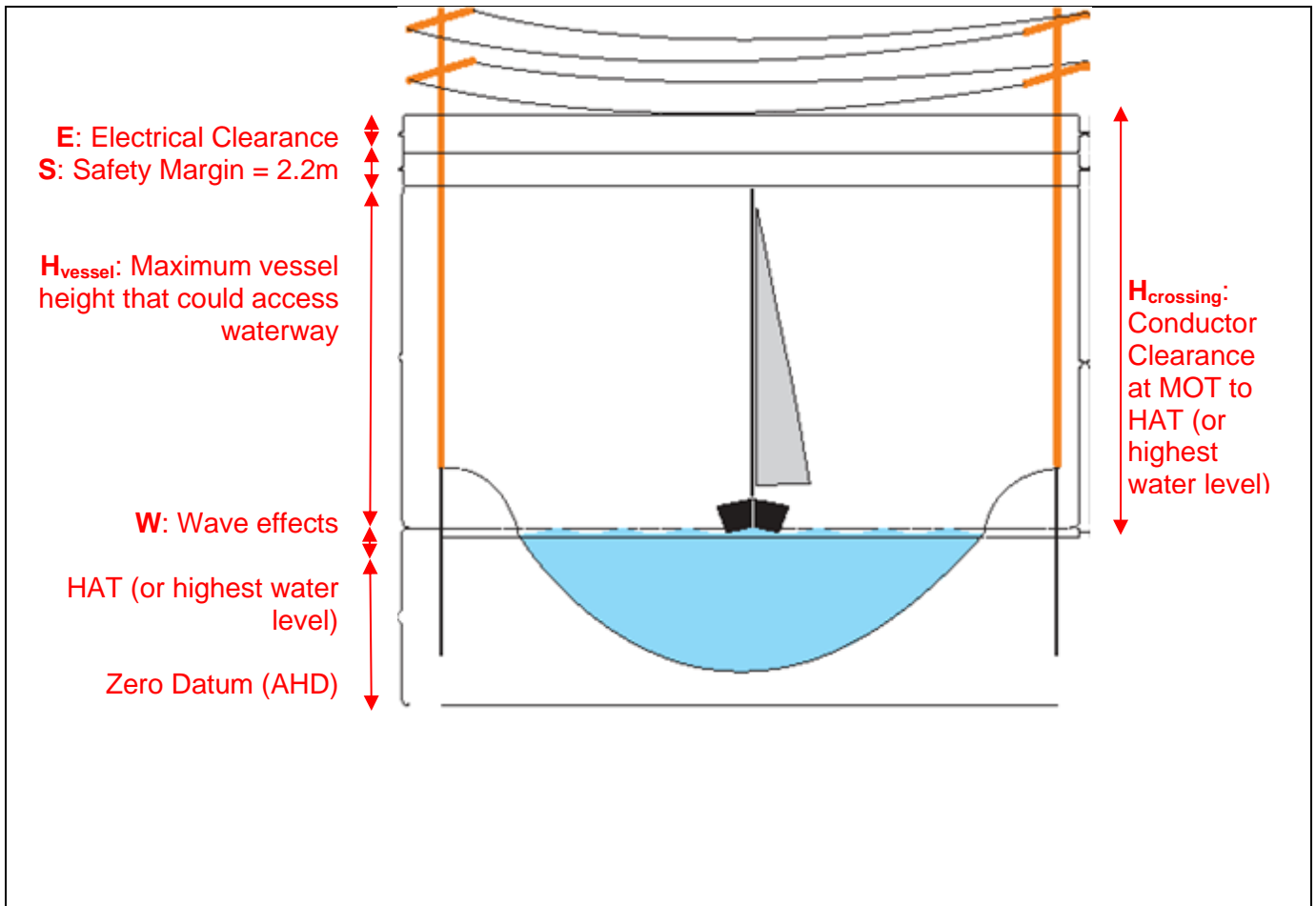

Figure 1: Design Height of New Crossing

The minimum required design height (H_{crossing}) is to be maintained, over all parts of the navigable waterway, under all conditions for the life of the crossing except during flood events. Allowance should be made for any planned activities, such as dredging, which has the potential to allow higher vessels to use the waterway. Consideration should also be given to the possibility of a person being the highest point of the vessel, for instance if they are standing on a flybridge or on the top deck of the vessel. If this is likely given the types of vessels which use the waterway, an allowance of 2.45m from the uppermost deck is required.

5.3.3.2 Submarine crossings

For submarine crossings the key information arising from the risk assessment may include but is not limited to information that may impact on a submarine cable eg:

- anchoring of vessels
- dredging of bed of the waterway
- strong water currents and/or erosion which may expose buried cable
- cable protection options eg burial / rock dumping
- presence of aquatic constraints eg seagrass.

5.3.3.3 Under-bored crossings

Under-bored crossings (ie cables installed under a waterway using trenchless technologies) should not have any adverse impact on navigation safety provided the level of the under-bore is beneath the level of the bed of the waterway and beneath any potential dredging or channel deepening activities. However the location of entry and exit points will need to be investigated to determine whether an under-bore is an option. For these reasons although under-bores are preferred from a risk perspective, they are not always practicable and can be cost prohibitive.

5.4 Preparation of detail design plans and construction

For overhead crossings, given the minimum design height of the proposed crossing above HAT (or highest water level) at maximum conductor operating temperature from Clause 5.3, it will be possible to carry out the necessary sag/tension calculations and determine pole attachment heights, pole strengths, etc, sufficient to include in a design drawing.

For submarine crossings, the information obtained from the risk assessment as discussed in Clause 5.3 will help determine the most appropriate location and method of installation for the proposed submarine (or under-bored) crossing. The cable installation including route and installation method is to comply with any specific requirements of the approval authorities. Marine survey may be necessary to analyse the topography and morphology of the bed of the waterway, water currents and tides along the proposed alignment. In all cases an environmental assessment of the cable route is required. The cable used is to be designed specifically for submarine applications. Details of the cable design are to be submitted to Ausgrid Transmission and Distribution Mains Manager for approval before procurement. The cable is to be installed in one continuous length across the waterway ie without joints.

The design drawing should include details of the signage to be provided including location, size, orientation, maximum vessel height, etc. Each post that supports signage is to be allocated a pole/asset number in SAP to facilitate ongoing maintenance.

5.5 Post-construction survey and maximum sag calculation

5.5.1 Overhead crossings

For all overhead crossings, the crossing is to be surveyed after completion of construction to confirm that the crossing has been constructed in accordance with the minimum clearance requirements of the design. The survey is to be conducted by a registered land Surveyor.

The conductors associated with the crossing are to be assumed to be at ambient temperature at the time of survey, and calculation is to be carried out to adjust the surveyed height to account for highest operating temperature. Based on the survey results the Maximum Vessel Height to be shown on signage shall be recalculated and checked against the risk assessment, the design and the height actually shown on the signage. If necessary, the height of the crossing and/or the Maximum Vessel Height shown on the signage is to be adjusted as appropriate.

For crossings constructed by Ausgrid the post-construction survey is to be conducted approximately one month after completion of the construction works to allow for pole movement, conductor creep, etc.

For contestable projects the ASP is responsible for ensuring that the survey, calculation to account for highest operating temperature, and any necessary adjustments to crossing height and/or signage is to be completed prior to commissioning. The ASP will also be responsible for any adjustments subsequent due to pole movement, conductor creep, etc during the warranty period.

Other survey details shall be as specified in Annexure B.

5.5.2 Submarine crossings

For submarine crossings installed via horizontal directional drilling bores as-built plans are to be compiled from drilling records and entry/exit points, as per NS159 Clause 6.15.

For submarine cables that are to be buried, the location of the cable on the bed of the waterway is to be surveyed between laying & burial. After installation the burial depth is to be verified via appropriate technology, eg parametric sub-bottom profiling, and bathymetry survey of any rock dumping areas.

6.0 SERVICE MAINS

Overhead service mains must not be installed as a waterway crossing. This is to prevent the height of an Ausgrid waterway crossing being altered through the customer changing the point of attachment.

Where a prospective customer's Connection Point is to be on the opposite side of a waterway from Ausgrid's distribution mains, Ausgrid's distribution mains must be extended to the opposite side of the waterway such that the poles on both sides of the waterway, and all poles between the crossing and Ausgrid's existing distribution mains, are Ausgrid poles.

Before any such crossing is constructed it will be necessary for the customer to negotiate with Ausgrid to agree to the construction of the crossing, as Ausgrid distribution mains, as a contestable project. Any such agreement will be subject to assessment and approval by Ausgrid.

Note: For these reasons the structures (poles), on both sides of the waterway, associated with any particular overhead crossing, must be owned by either Ausgrid (preferably) or the customer - see Section 7.0 below. An Ausgrid structure on one side of the waterway must not be connected to a privately owned structure on the other side of the waterway.

7.0 PRIVATE CROSSINGS

In accordance with the marine legislation (as defined in the Ports and Maritime Administration Act 1995 (NSW)), obstructions and encroachments must not be constructed in, on or over a navigable waterway without the prior approval of Roads and Maritime Services (RMS) and must not constitute an obstruction to navigation. This applies to overhead, under-bored or submarine wiring systems including services, consumers mains, submains or final subcircuits which cross navigable waterways.

Approvals may also be required from various agencies including but not limited to the NSW Department of Primary Industries - Lands, local councils, etc.

Where private wiring is to be installed across a waterway it is the responsibility of the customer to make all necessary enquiries to determine whether the waterway is a navigable waterway and to obtain all necessary approvals from RMS and any other relevant authorities.

In addition to being approved by RMS and other relevant authorities, all private wiring across navigable waterways must comply with the requirements of AS/NZS 3000: Wiring Rules, Service and Installation Rules of NSW, AS 6947: Crossing of Waterways by Electricity Infrastructure and any other conditions specified by RMS and other authorities. This includes design, construction, and ongoing operation and maintenance.

If the customer cannot obtain approval from RMS, or the other relevant authorities, to construct private wiring across a waterway, the customer may negotiate with Ausgrid to agree to the construction of the crossing, as Ausgrid distribution mains (instead of private mains). The Ausgrid distribution mains must be supplied directly from Ausgrid's network and the customer's installation will need to be configured accordingly. The work associated with this would be a contestable project. Any such agreement will be subject to assessment and approval by Ausgrid, and approval for the crossing from various agencies including but not limited to the NSW Department of Primary Industries - Lands, local councils, etc.

8.0 WARNING SIGNS

8.1 General

Warning signs in accordance with the Code and AS 6947 shall be installed for each crossing. This is a matter of policy and applies irrespective of whether the risk assessment for the crossing deems signage to be a mandatory or optional risk treatment option.

8.2 Signage for multiple adjacent crossings

Where there are multiple adjacent crossings one set of signs only should be installed. This includes dual circuit lines. For overhead crossings, the Maximum Vessel Height to be shown on such signs is the height relating to the lowest crossing in the group.

8.3 Signage design requirements

8.3.1 General

Signs should be designed to have a minimum design life of 25 years. Signs should preferably be installed above the intertidal zone with the bottom edge of the sign at a nominal mounting height of 2200mm from ground level. Signs installed in the waterway, within the intertidal zone or on cliffs immediately beside the waterway should be installed with the bottom edge of the sign at a nominal mounting height of 1000mm above HAT.

Wherever practicable signage associated with crossings over waterways subject to flooding should be located above the flood level, or as high as reasonably possible above the flood level, so it does not become submerged in floods. However this must not be at the expense of keeping the signage clearly visible from the waterway during non-flood conditions.

To facilitate ongoing maintenance, each post that supports signage is to be allocated a pole/asset number in SAP, in accordance with NS148, and each post is to have its number affixed on the bottom edge of the sign immediately adjacent to the post. The location of each post and any other details as appropriate are to be recorded in GIS in accordance with NS100. Inspection / maintenance requirements shall be in accordance with the current line inspection and pole inspection processes for steel poles as required by Network Standards NS166 and NS145 and Network Technical Maintenance Plans HO101, HO102, HO 103, HO108, HO109 and HO105. For each waterway crossing sign support the following information is required for entry into SAP:

- I. Pole number including map prefix
- II. Material type – Stainless Steel post - sign, Steel post - sign
- III. Pole size – Unknown, Footing and Soil Type
- IV. Location
- V. Street no to be entered as waterway crossing number eg. EA09.
- VI. Waterway crossing number and waterway name (to be entered in the comments field)
- VII. A field recording / location sketch is required to be provided for entry / update of the GIS (when *constructed*).

Signs are minor structures; the failure of a sign itself is not likely to endanger human life; and would have small economic, social or environmental consequences. Any failure should be detected and rectified during Ausgrid’s routine inspection/maintenance programs. For these reasons signage shall be designed to have an Importance Level of 1 (“Low” consequence of failure) in accordance with AS/NZS 1170.0.

Refer to Ausgrid drawing No. 237975 (single discrete sign) or 238007 (bidirectional arrangement) as appropriate for further details.

Vegetation associated with warning signs shall be managed in accordance with the relevant requirements of NS 179 and Ausgrid’s environmental Guidelines and Standards.

Signage installations may need to be the subject of an environmental impact assessment (EIA) in accordance with the State Environmental Planning Policy (Infrastructure) 2007 and NUS174 Environmental Procedures. These should be referred to Ausgrid Environmental Services Branch for assistance and advice. Particular situations which may require an EIA include but are not limited to:

- disturbance of soil,
- clearing or trimming of vegetation.

8.3.2 Overhead crossing signage design requirements

Overhead waterway crossings should be designed, constructed and maintained to comply with the Code and AS 6947 regarding the Maximum Vessel Height, which above everything else is the most important risk mitigation factor. The Maximum Vessel Height to be shown on warning signs is to be determined according to the following calculation:

Table 2 – Overhead Crossing Signage Design Requirements

$H_{sign} = (H_{crossing} - S - E - W)$ rounded down to next whole metre,

where:

H_{sign}	=	Maximum Vessel Height to be shown on signage ¹	
$H_{crossing}$	=	Minimum height of crossing conductors above HAT (or highest water level ²) at maximum operating temperature.	
S	=	Safety margin (= 2.2m in all cases)	
E	=	Electrical clearance	= 0.3m for voltage ≤ 33kV (including communications cables)
			= 0.8m for 33kV > voltage ≤ 132kV
W	=	Allowance for wave height (as determined during the site visit and investigation discussed in Section 5.3)	

Notes:

- 1) It may be prudent to wait and confirm the final minimum height of crossing conductors as determined by the post-construction survey before calculating H_{sign} and installing signage.
- 2) For tidal waterways the crossing is to be designed so that the conductors achieve the minimum height above HAT. For non-tidal waterways the highest water level will need to be determined and the crossing is to be designed so that the conductors achieve the minimum height above this level which is generally relative to AHD rather than HAT.

8.4 Supplementary flooding signs

Supplementary flooding signs as specified in AS 6947 are to be attached to the signage associated with overhead crossings in waterways subject to flooding.

8.5 Alteration of signage

Whenever the height of an overhead crossing is altered the risk must be reassessed and the maximum vessel height shown on the associated signage must be recalculated and amended accordingly. Where the existing signage has reached the end of its useful life or is not economical to amend it should be replaced completely with new signage. Otherwise the preferred method of amending the height shown is to overlay the old number(s) with new numbers printed/painted on sheet metal such that the new number(s):

- Completely cover the old/incorrect number(s),
- Have the same colour font style and size as the old number(s) (as per AS6947-2009 Figures A4 or A5)
- Align properly on the sign with any existing number(s) (as per AS6947-2009 Figures A4 or A5)
- Printed/painted on sheet metal that is the same base material as the sign
- Are attached permanently with appropriate corrosion resistant fixings
- Have no burrs or sharp edges
- Manufactured and attached with materials and of surface finish giving similar life expectancy as the sign.

9.0 DOCUMENTATION

The documentation to be provided for each waterway crossing shall consist of:

- risk assessment,
- overhead line, submarine or under-bored cable design drawing,
- post-construction survey drawings,
- post-construction sag calculation drawing for overhead crossing.

9.1 Risk assessment

Risk Assessment documents shall be prepared by Ausgrid in accordance with NEG OH14, in MS-Word, generally in the same format as existing risk assessments held in Balin and Engineering Standards and Research shared network drive as follows, depending on the particular region in which the waterway crossings is located:

Table 3 – Risk assessment file locations

Region	Network Drive / File Location
Central Coast	\\Eahobcfp01\Head Office\Engineering_Std_and_Research\Waterway Crossings\Risk Assessments Central Coast (URS)\Final Reports
Lower Hunter	\\Eahobcfp01\Head Office\Engineering_Std_and_Research\Waterway Crossings\Risk Assessments Hunter (PB)\Final Approved Reports
Sydney South and North	\\Eahobcfp01\Head Office\Engineering_Std_and_Research\Waterway Crossings\Risk Assessments Sydney (AECOM)\Final Reports

Where a revised version of an existing risk assessment is required, the preceding version is to be retained and the new version is to be saved as a separate revision, so that the history of each crossing is maintained and can be easily followed. Superseded versions shall be marked as such and shall include a reference to the current/revised version.

A .pdf version of the current version shall be kept in Balin under the "Waterway Crossings" subject heading and appropriate region sub-heading.

9.2 Design drawings

Design drawings are to be in accordance with NS104, in the appropriate format suitable for construction.

In addition to normal design drawings a separate design drawing is to be provided showing pertinent details of just the crossing itself. For overhead crossings this is to include but limited to: the poles/structures on either side of the waterway, the crossing span, an outline of the banks of the waterway, HAT, etc - refer to [Figure C1 – Typical Waterway Crossing Span Design Drawing](#) for a typical example. For submarine or under-bored crossings the drawing is to include but not limited to: cable entry/exit locations, location of UG/Ohs if adjacent to crossing, installation method (trenched, under-bored), depth of cover beneath bed of waterway, etc.

For non-contestable projects all waterway crossing designs are to be prepared by Mains Design Section, Project Development. Copies of any new or revised design drawings shall be kept in ProjectWise in a folder under the project name. Revised design drawings shall be kept in ProjectWise as a separate revision of the preceding version so that the history of each crossing is maintained and can be easily followed. Superseded versions shall be marked as such and shall include a reference to the current/revised version. A .pdf version of each approved drawing is to be published in TDMS.

For contestable projects the separate drawing showing just the crossing must also include a drawing number allocated from the TDMS. Ausgrid will attach a copy of the approved drawing(s) to the TDMS.

9.3 Survey drawings

Waterway crossing survey drawings shall be prepared in AutoCAD, generally in the same format as existing survey drawings which are held in TDMS. Each drawing shall be assigned a unique TDMS drawing number. Refer to Annexure B for further details.

Where a revised survey drawing is required it is to be prepared as a revision of the preceding version (ie a new drawing should not normally be issued). The revised drawing and preceding version(s) are to be retained in TDMS so that the history of each crossing is maintained and can be easily followed.

.pdf versions of all survey drawings shall be kept in TDMS for use by general TDMS users.

9.4 GIS

GIS is to show:

- the crossing
- warning signs
- sign posts
- crossing number EAXXX
- height at maximum sag above HAT (or highest water level).

10.0 RECORDKEEPING

The table below identifies the types of records relating to the process, their storage location and retention period.

Table 4 – Recordkeeping

Type of Record	Storage Location	Retention Period*
Approved copy of the network standard	BMS Network sub process Standard – Company	Unlimited
Draft Copies of the network standard during amendment/creation	HPRM Work Folder for Network Standards (HPRM ref. 2014/21250/239)	Unlimited
Working documents (emails, memos, impact assessment reports, etc.)	HPRM Work Folder for Network Standards (HPRM ref. 2014/21250/239)	Unlimited

* The following retention periods are subject to change eg if the records are required for legal matters or legislative changes. Before disposal, retention periods should be checked and authorised by the Records Manager.

11.0 AUTHORITIES AND RESPONSIBILITIES

For this network standard the authorities and responsibilities of Ausgrid employees and managers in relation to content, management and document control of this network standard can be obtained from the Company Procedure (Network) – Production / Review of Engineering Technical Documents within BMS. The responsibilities of persons for the design or construction work detailed in this network standard are identified throughout this standard in the context of the requirements to which they apply.

12.0 DOCUMENT CONTROL

Content Coordinator : Manager – Transmission and Distribution Mains Engineering

Distribution Coordinator : Senior Engineer – Guidelines, Policies and Standards



Annexure A –Sample Compliance Checklist

Network Standard Checklist Form

NS268 Specification for Design and Construction of Waterway Crossings

Project Identification:	
Prepared by:	Date:

This checklist is for internal Ausgrid use only and does not apply to ASPs or contractors who have specific compliance requirements in relation to Contestable project works. The checklist is unique for each network standard and is available within BALIN and the BMS as a separate form that can be amended as required, completed and saved in TRIM with the other project documentation.

This section is used to identify compliance checks that when applied to the work associated with this Network Standard will satisfy an audit process to establish that the requirements of the standard have been followed. It is expected that applicable items would normally be checked as Comply (Yes) as non-compliance is generally not tolerated.

Where non-compliance is the result of specific site conditions or design decisions this needs to be identified in the notes section of the form for each non-compliance and approval sought from an appropriately authorised Ausgrid manager responsible for design approval.

Should additional information be available to document non-compliance decisions, these can be attached to the checklist form. The checklist and any attached explanatory notes should be saved in the project document repository.

Item	Description	Refer clause	Completed/ Actioned
Scope			
	This Network Standard is intended to assist Ausgrid employees and ASPs involved in the design and construction of Ausgrid overhead, under-bored and submarine waterway crossings including 132kV, 66kV, 33kV, 22kV, 11kV, LV and communications cables		
Design and Construction			
1	Approvals obtained from all necessary agencies	5.2	Yes/No/NA
2	Risk assessment in accordance with NEG OH14	5.3	Yes/No/NA
3	Key information arising from risk assessment	5.3.3	Yes/No/NA
4	Preparation of detailed design plans	5.4	Yes/No/NA
5	Post construction survey	5.5	Yes/No/NA
Other Sections			
6	Overhead service mains not to be installed as waterway crossings	6.0	Yes/No/NA
7	Private crossings approve by RMS and comply with AS/NZS3000, AS6947, and	7.0	Yes/No/NA

	any other conditions specified by RMS and other authorities		
8	Warning signs in accordance with Code, AS6947, and drawing 237975 or drawing 238007 as appropriate	8.0	Yes/No/NA
9	Documentation prepared and filed as required	9.0	Yes/No/NA

Notes:

.....

.....

.....

.....

.....

Prepared by
 {Name}
{Position Title}

Date: ____/____/____

Approved by
 {Name}
{Section Manager Title}

Date: ____/____/____

Endorsed by
 {Name}
{Appropriate Branch Manager Title – where required}

Date: ____/____/____

Annexure B – Overhead Waterway Crossing Survey Specification

B1 General

The field survey of an overhead crossings of a navigable waterway is to determine:-

- (a) The location of the poles and relevant points of attachment.
- (b) The edge of the waterway.
- (c) Existing warning signs.
- (d) The extent of mangroves or other growth that may obscure warning signs.
- (e) The AHD level of a number of observations along the catenary of the lowest conductor.
- (f) Water level at the time of survey.

The data from the survey will be used in conjunction with further electrical calculations to determine/confirm the maximum vessel height that can safely pass under the overhead mains.

The data may also be used in the re-design of overhead crossings that do not comply with the requirements of the Crossings of NSW Navigable Waters: Electricity Industries Code (the Code).

The required survey will be a mixture of profile and detail survey and where warranted, boundary definition.

Specific Ausgrid codes and layers are to be used as per the provided point codes shown in clause B17.

The codes used must be exactly as shown in the file and are case sensitive.

All data must be presented on M.G.A. grid co-ordinates and A.H.D.

B2 Provision of information by Ausgrid

Upon request Ausgrid will provide:-

- example Crossing drawing file eg: EA NSW MARITIME CROSSING TEMPLATE .dwg,
- example Crossing pdf file eg: EA NSW MARITIME CROSSING TEMPLATE .pdf
- RL for the appropriate tidal/water level plane.

B3 Survey requirements

- Survey control stations and recovery marks should be of a substantial nature and location so they can be utilised for future, regular check surveys on the crossings.
- Do not place stakes at survey stations where they are located in pedestrian areas or where they may affect livestock.
- Do not place large paint markings on Ausgrid poles as they may conflict with markings used by pole maintenance crews.
- Minimise the use of spray paint on roadway and pavement areas.
- Ausgrid requires that only minimal vegetation trimming be allowed to assist in the survey.

B4 Survey accuracy

- Survey control and traverse stations to appropriate survey standard.
- Conductor and Point of Attachment observations: + / - 50mm horizontally and vertically.
- Detail survey observations: + / - 50mm horizontally and vertically.
- Final boundary definition: +/- 100mm.

B5 Methodology

Where appropriate the surveys should be undertaken by direct observations. However, sound geometric positioning of observation stations should be sought, to avoid acute angle observations.

Some sites will require positioning of observation stations a long distance from the conductors. In these instances it may be impractical for direct observations. Horizontal and vertical angle observations may be the appropriate method to employ in these instances.

Care should be taken with long distance observations to conductors so that the correct conductor is identified and observed.

B6 Pole identification

Each pole is to be referenced by its Ausgrid asset number eg. ET-0073.

Occasionally the field numbering of existing poles does not include “zeros”, hence ET-73.

Where a Ausgrid GIS extract is provided, please check and confirm that the pole numbers shown on drawings are the same as the GIS. If there is a genuine difference in the field pole numbering arrangements are to be made to rectify the discrepancy.

The following are to be located in x,y,z format.

- The centre of the base of each power pole at ground level.
- All other, higher, points of attachment or crossarms.
- The top of the pole (observation may be taken by reflectorless observation to face of pole).
- All associated stay poles and ground anchor entry points (where survey access at ground level is difficult these points may be located approximately by reference to the crossing pole position).

B7 Catenary observations and points of attachment

B7.1 Catenary

Where the LOWEST conductor is clearly identifiable, catenary observations are to be along that conductor, and no other catenary observations are required on any other spans or conductors.

Where the conductors are in a horizontal construction and it is difficult to determine which conductor is actually the lowest, observation and calculations will be required on all of the possible lowest conductors to determine which actual conductor is LOWEST. Only information on the lowest conductor is to be included in the AutoCAD model and the CSV file in this situation.

Occasionally crossings are constructed so that the conductor configuration changes from one side of the crossing to the other. For example the conductors may start on one side as horizontal construction and finish on the other as vertical (or delta) construction. In these situations Ausgrid requires all three conductors to be surveyed and the results shown on three separate CSV files. Each CSV file will contain all ground points and all pole points and points for one conductor only. It will also be necessary on each conductor to take an additional observation close to each point of attachment (this allows for attachment points to be correctly identified in the overhead line design software (eg TLPro) model). The drawing should show only the conductor which the surveyor considers to be the lowest.

In all cases, each conductor surveyed requires a minimum of five catenary observations approximately equally spaced, along the entire span of the conductor.

If “marker balls” have been placed on the lowest conductor, make sure that observations are also taken to the conductor adjacent to the “marker ball”. If the “marker balls” are appropriately spaced, the observations near them will contribute to the minimum requirement of five equally spaced observations.

The following data is to be observed/recorded and entered into the “Catenary Observation” table in the drawing title block.

- Ambient: the ambient air temperature in degrees Celsius.
- Atmospheric Conditions: The condition of the weather - sunny, light cloud, overcast, dark and stormy, etc.
- Wind Speed: wind speed in meters per second with comment on whether the wind is still, gentle breeze, strong breeze, gusty.
- Wind Angle: the angle of the wind relative to the conductor, in degrees. A value of 90 degrees would indicate that the wind is blowing perpendicular to the conductor. A single indicative wind direction arrow, showing the angle of the wind to the conductor should be shown on the plan. See Ausgrid example Crossing drawing.
- Local Time: the time of day.
- Solar Day: the date of the Survey.
- Conductor observations should not be undertaken in strong breezes or wind.

On some sites it will be necessary to undertake the required catenary observations at either significantly different times and/or from different control stations. In these cases separate “Catenary Observation” tables will be required. See Ausgrid example Crossing drawing.

Note: occasionally dual circuit crossings will be encountered with vertical conductors, three on one side and three on the other side of the structure. In these cases each circuit or feeder (consisting of three vertical conductors) will be treated as a separate crossing. Two PDF drawings and two CSV files will be required. One AutoCAD file will suffice with a layout tab for each drawing identified as “A” and “B”. There will be one crossing number and one drawing number, however there will be an “A” and “B” added to the Crossing number to create two distinct crossing identifiers, EAxxxA and EAxxxB.

B7.2 Points of attachment

The points of attachment where the lowest conductor (that passes over the waterway) attaches to the two poles/towers/insulators are to be surveyed.

It is important to identify if the lowest Ausgrid conductor attachment point is via a termination at the pole or crossarm, or is in suspension via a pin or suspension insulator.

- Termination – If both ends are terminated, there is no additional survey requirements along the pole line.
- Suspension – If one or both ends are in suspension, the x,y location of the pole is required, along the pole line, up to the next termination or for three spans.

See Figure B1 – River Crossing Survey Requirements for clarification.

Where sub-transmission (22kV, 33kV, 66kV and 132kV) insulators are terminated, there is an additional requirement to also observe those parts of the insulator as indicated on the photos in Clause B19.

There are no additional requirements relating to sub-transmission insulators in suspension.

See Clause B19 for photos showing examples of termination, pin and suspension insulators.

B7.3 Plan drawing

- The extent of the plan on the drawing is to be such that it shows only the entire LOWEST span that crosses the waterway and the supporting poles.
- The location of any additional poles, additional traverse, connections to pole bases or tops, etc, is to be shown only in "Model Space" and in a non-plotting layer.
- The plan should be drawn, following normal convention, such that the north point is drawn up the page. If possible, the plan and profile should be drawn so that the profile view is looking upstream.
- See Ausgrid example Crossing drawing.

B7.4 Profile drawing

The extent of the profile on the drawing is to be such that it shows only the entire LOWEST span that crosses the waterway and the supporting poles.

The profile should be drawn, following normal convention, such that it is correctly orientated with the above plan. Wherever reasonably practicable, the plan and profile should be drawn so that the profile view is looking upstream.

The location and values of the catenary observations is to be shown in the same manner as that on the Ausgrid example Crossing drawing.

Additionally, the location and RL of the calculated low point of the conductor is to be placed on the profile and attention paid to the drawn catenary so that the linework passes through the calculated low point. All references to the calculated low point are to be placed in a non-plotting layer.

If more than one "Catenary Observation" table is required they should be shown as on the Ausgrid example Crossing drawing.

B7.5 CSV file

The csv file is to contain only the information relative to:

- The LOWEST conductor,
- The subject poles, points of attachment and additional crossarms etc,
- The ground profile including the surveyed edges of water and any false profile points,
- Additional poles if required.

B7.6 Locality plan

This should be prepared if required - ideally, an extract from the digital UBD with the crossing shown. Other detail relating to locked gates, access requirements and other relevant information to assist others visiting the site should be added.

B8 Edge of waterway and location

The location of the edge of the waterway and the water level at the time of survey is to be located under the subject conductor. Where terrain/vegetation permits, additional observations should be obtained to allow the depiction of the edge of the waterway for a short distance either side of the crossing.

See Example Crossing drawing for depiction of edge of water by survey and by approximation.

B9 Ground profile

Where practical, a single line profile of ground observations is required, directly under the subject conductor, (as best determined), from five metres behind the subject poles to the water's edge.

Where it is impractical to survey a complete ground profile, the following processes may be used:-

- Transfer the approximate terrain from a suitably scaled topographic map.

Where additional poles need to be captured, the additional ground profile is not required if the terrain/vegetation is difficult. However, a false profile is to be created and extended, based on the ground height at the nearest crossing pole, to the next termination or three spans onward (whichever is shortest).

See Figure B1 – River Crossing Survey Requirements for clarification.

Also see “Model Space” in Example Crossing drawing.

B10 Detail survey

The following are to be located in x,y,z format :-

- Any structures located under the powerlines.
- The Ausgrid “warning” signs relating to the overhead mains. Some of these signs will be located on the bank and others within the waterway.
- Any road traffic signs that are higher than 2 metres and larger than 1m² located under the existing powerlines.
- Any boat ramps that are in the immediate vicinity.
- The location of and underside RL of any bridges or pipelines that span the waterway in the nearby vicinity. The underside RL may be shown in a statement within the “Notes” box if the bridge or pipeline location cannot be shown in the available plan area.

B11 Tidal or water level planes

A number of different planes may be used:

- Highest Astronomical Tide – For tidal waters.
- Mean Water Level – For non-tidal waters.
- Maximum Water Level – for impounded waters.

For each site Ausgrid will provide an RL for the appropriate Tidal / Water Level Plane.

B12 Photographs

Photographs of the poles are required to assist the engineers in calculating the maximum sag.

High quality images are required to enable closer visual inspection of the conductor attachments, etc.

As a minimum the following three photographs of each pole or structure are required:

- close up showing the structure identification detail (number plaque),
- the complete extent of the pole with as little foreground foliage as possible and
- detail of the pole construction (crossarms, points of attachment etc).

Photographs of at least 4 mega pixels (MP) resolution are required. It is important to note that for a 4MP image, the image dimensions are in the vicinity of 2,272 x 1,760 pixels. For a 4MP camera to take that image the camera must be set to record the largest number of pixels with the least compression.

Notes: The pole photographs should be named XX1234a, XX1234b, XX1234c, etc. For example the photographs of pole ET-0073, (or ET-73 as it may be marked in the field) would be named ET0073a, etc.

An indicative directional arrow of each photograph taken shall be recorded on the CAD drawing in "Model Space" only.

B13 Survey searches

The surveyor is to undertake all cadastral, status and survey control searches and retain them for possible latter reference by Ausgrid.

B14 Boundary definition

- Where a cadastral boundary is within the vicinity of the crossing the boundary is to be defined to enable an offset to be shown + / - 100mm.
- Investigate and show any easements, rights of way or other interests in favour of Ausgrid or other parties and authorities that are in the vicinity of the surveyed line.
- Do not mark any boundaries.

B15 Existing services

- Locate any visible services manholes, pits, etc in the immediate vicinity of each pole.
- a DBYD utility services search is not required.

B16 Presentation of data

Photographs are to be provided on a CD.

The data is to be presented in the following file formats and the files must be named using the following conventions:

- 1.S19xxx.csv [S19xxxA.csv and S19xxxB.csv for dual crossing] – Containing all x,y,z, observations, using only the codes shown below in clause B17. The columns in the file are to be Easting, Northing, Elevation, Feature Code and Description. The "Description" column may contain comments such as the pole number, etc.
- 2.S19xxx.dwg – The file must be created in AutoCAD format and be a 2D drawing incorporating the provided EA Crossing plan form and based on the provided example Crossing drawing. Do not show voltages of conductors however surveyed points need to be stated. ie cross arm king bolt or insulator.
3. See "Model" in the example Crossing drawing for depiction of additional traverse, connections and poles that may have been surveyed or the required statement if additional poles are not surveyed.
- 3.S19xxx.pdf (S19xxxA.pdf and S19xxxB.pdf for dual crossing).

B17 Ausgrid survey code/layer codelist

Ausgrid Codelist

Code/Layer	Description	Code/Layer	Description
bd Prefix Building		ea Prefix Energy Australia	
bdAWN	Building Awning	eaABC	Aerial Bundled Conductors
bdBOC	Building Corner	eaADSS	Fibre Optic
bdBDL	Building Line	eaCOM	Communications/Pilot Cable
bdBUS	Bus Shelter	eaKSUB	Kiosk Sub Station
bdBWL	Brick Wall	eaMS	Mid Span
bdCOL	Building Column	eaOHBB	Overhead Bus Bar
bdCONC	Concrete Pad	eaOHC	Overhead Conductor
bdDOOR	Building Door	eaOHEW	Overhead Earth Wire
bdFAC	Building Fascia/Eave	eaOHFB	Overhead Feeder Bay
bdFCE	Fence	eaOHPA	Overhead Point of Attachment
bdFCEC	Fence - Conductive	eaPIL	Pillar
bdFL	Floor Level	eaPowerline	Line Joining Pole Centres
bdFLGP	Flag Pole	eaPP	Power Pole
bdFLGP	Flag Pole Top	eaPPAtt	Power Pole Attachment
bdFP	Fence Post	eaPPEG	Pole Peg
bdGTE	Gate	eaPPGA	Ground Anchor
bdOPASS	Overpass	eaPPLV	Low Voltage Power Pole
bdPATIO	Patio	eaPPSL	Street Light Pole
bdRR	Roof Ridgeline	eaPPTop	Top of Power Pole
bdRWB	Brick Retaining Wall	eaPstay	Stay Pole
bdRWC	Concrete Retaining Wall	eaSign	Waterways or other EA Sign
bdRWL	Rock Wall	eaSLAtt	Street Light Attachment Point
bdRWM	Metal Retaining Wall	eaSWire	Stay wire at Power Pole
bdRWR	Rock Retaining Wall	eaTOD	Tee Off Direction
bdRWT	Timber Retaining Wall	eaUGC	Underground Cable
bdSGN	Advertising Sign	eaUGC PIT	Underground Cable Pit
bdTBOX	Telephone Box	eaUGC DUC	Underground Cable Duct
bdVER	Building Verandah	eaUGJBAY	Underground Joint Bay
bdWHF	Wharf	eaUGJT	Underground Joint
bdWI	Wall Intersection	eaUGLV	Underground Low Voltage
		eaUGOPF	Underground Optical Fibre
		eaUGC-DBYD	Underground Cable as per DBYD
		eaOHC-DBYD	Overhead Conductor as per DBYD
		eaUGTCL	Underground Trench Centreline
		eaUGTE	Underground Trench Edge
		eaXARM	Crossarm
		eaXARME	End of Crossarm
cm Prefix Communications		el Prefix Electrical	
cmCBT	Comms Cabinet	elOHAT	Electrical Overhead Attachment
cmCM	Comms Marker	elOHC	Electrical Overhead Conductor
cmCT	Comms Cable Tray	elPIL	Electrical Pillar
cmPIL	Comms Pillar	elPP	Electrical Power Pole
cmPIT	Comms Pit	elTWCL	Electrical Tower Centreline
cmCP	Comms Pole	elTWL	Electrical Tower Leg
cmCPTop	Comms Top of Pole	elUGC	Electrical Underground Cable
cmOC	Comms Overhead Cable		
cmRM	Comms Reference marker		
cmSCB	Comms Signal Cable		
cmUC	Comms Underground Cable		
cmX	Comms Crossing		
cmCPGA	Comms Ground Anchor		
cmOC-DBYD	Comms Overhead cable as per DBYD		
cmUC-DBYD	Comms Underground cable as per DBYD		
dr Prefix Drainage		ga Prefix Gas	
drCUL	Drainage Culvert	gaGM	Gas Marker
drDD	Dish Drain	gaGMT	Gas Meter
drDIP	Drainage Inlet Pit	gaPIPE	Gas Pipe
drGRT	Drainage Grate	gaPIPE-DBYD	Gas Pipe as per DBYD
drHW	Drainage Headwall	gaGV	Gas Valve
drINV	Drainage Invert	gaGX	Gas Crossing
drKIP	Kerb Inlet Pit		
drMH	Drainage Man Hole		
drOL	Drainage obvert Level		
drPIPE	Drainage pipe		
drPIPE-DBYD	Drainage pipe as per DBYD		
drPIPE-NOSVY	Drainage pipe (where there is no DBYD)		
drSIP	Drainage Surface Inlet Pit		
drWC	Water Course		
drWL	Water Line		
		gt Prefix Geotechnical	
		gtBH	Borehole
		gtCPT	Cone Penetrometer
		gtTPIT	Test Pit
		ms Prefix Miscellaneous	
		msMH	Manhole
		msPIPE	Pipe
		msPIT	Pit

B18 Waterway crossing survey requirements

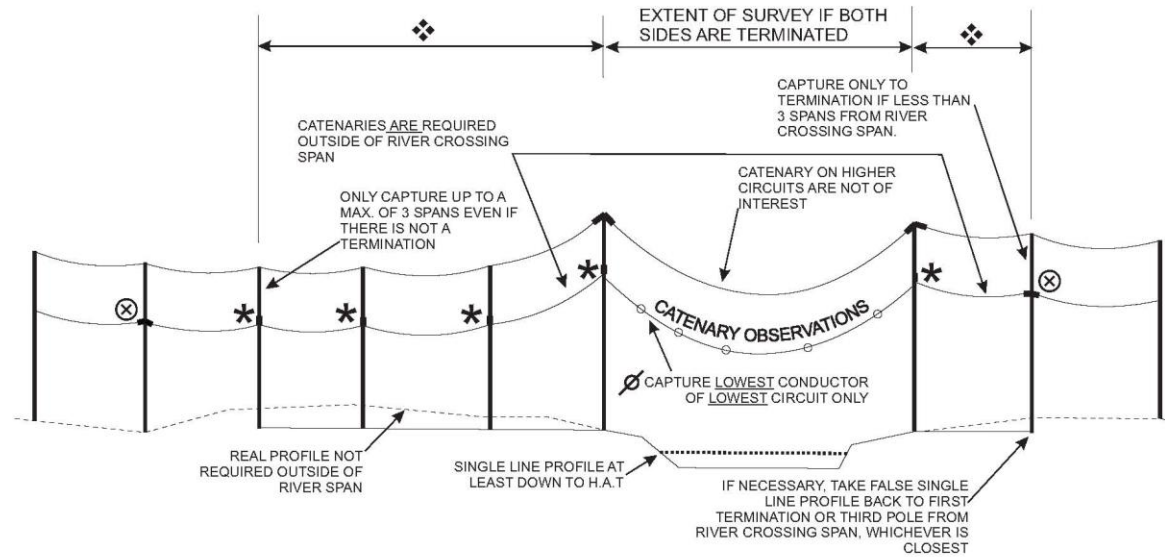

RIVER CROSSING SURVEY REQUIREMENTS

TYPICAL HORIZONTAL CONSTRUCTION CROSSING.
(OTHER TYPES OF CROSSINGS EXIST - SEE BRIEF.)

- NOTES:
- ⊗ A MINIMUM OF FIVE APPROXIMATELY EQUALLY SPACED CATENARY OBSERVATIONS
 - * SUSPENSION CONSTRUCTION
 - ⊗ TERMINATION CONSTRUCTION
 - ◇ IF SURVEYED THE POLES ARE TO HAVE X, Y, Z AT POLE BASE. THE 'Z' VALUE MAY BE 'CREATED' BY DUPLICATING THE SAME 'Z' VALUE AS AT THE CROSSING POLE. IF NOT SURVEYED, INCLUDE A STATEMENT IN AUTOCAD MODEL SIMILAR TO THAT SHOWN IN EXAMPLE DRAWING.

Figure B1 – River Crossing Survey Requirements

B19 Attachment point photos

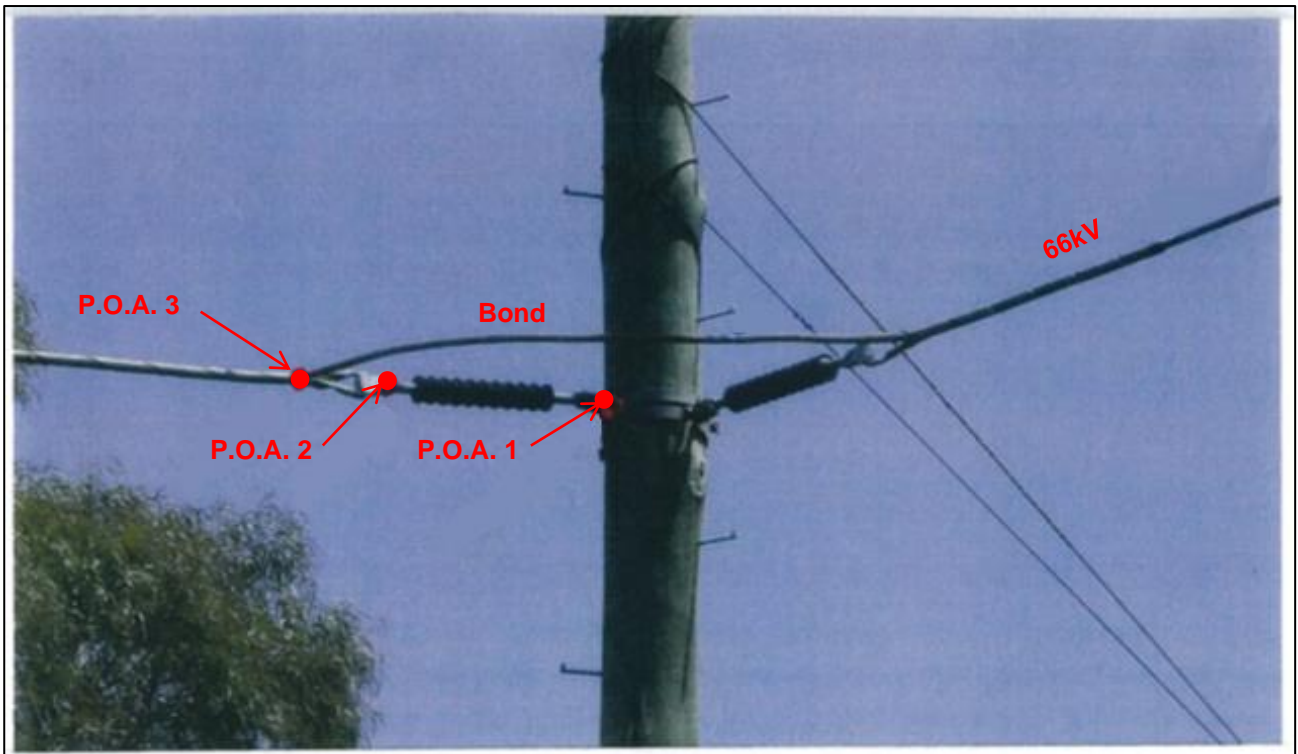

Figure B2: Subtransmission (66kV) Terminations
(all to be coded "eaOHPA")



Figure B3: Subtransmission (132kV) Terminations
(all to be coded "eaOHPA")

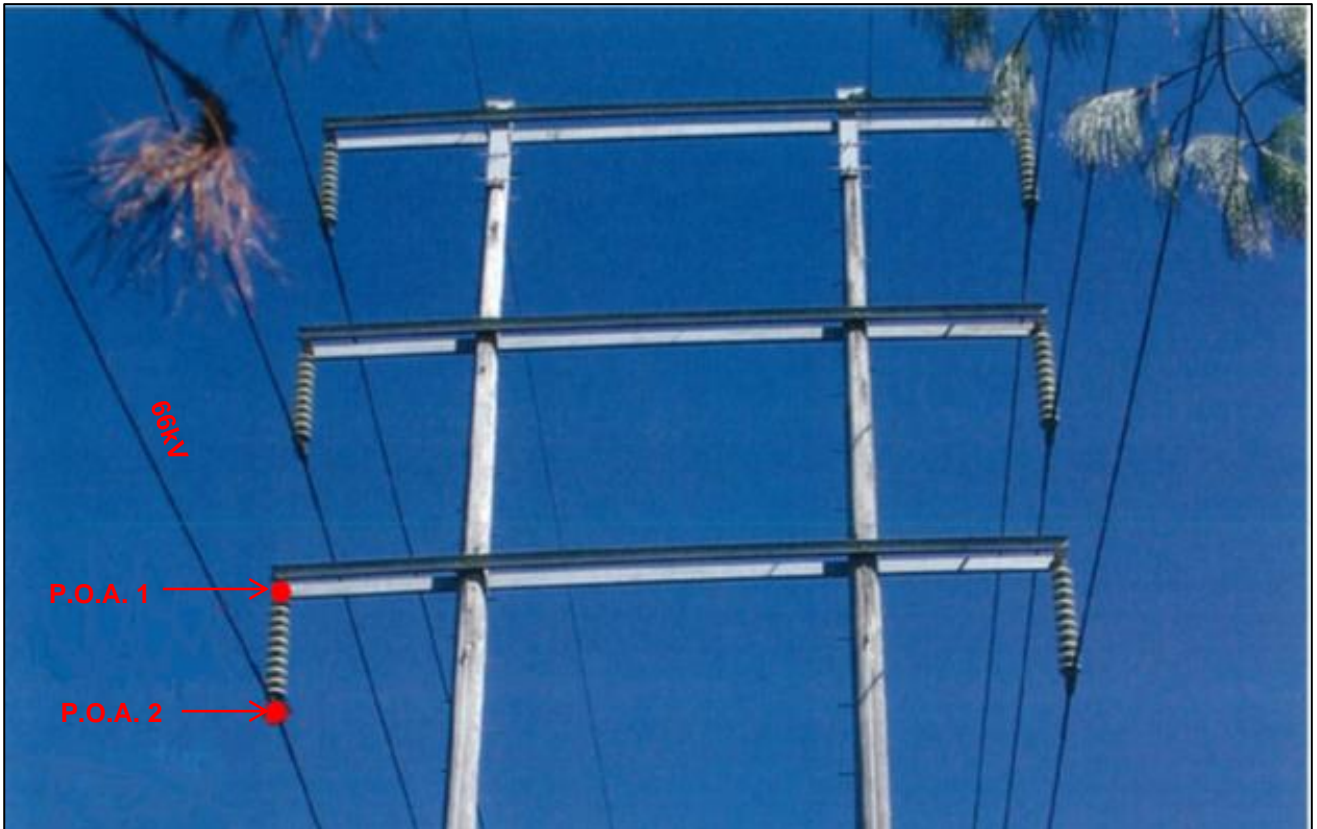

Figure B4: Subtransmission (66kV) Suspensions

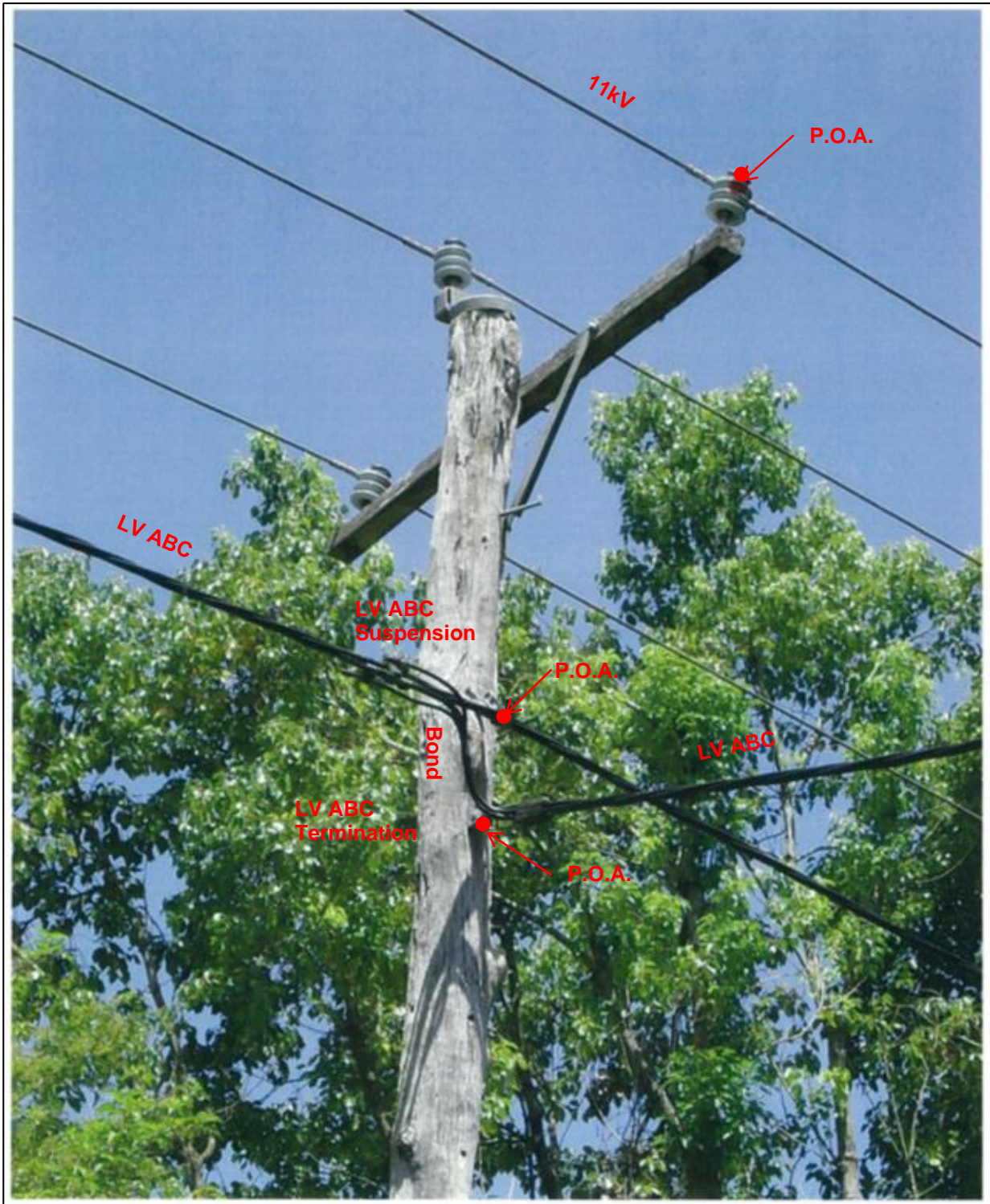

Figure B5: High voltage (11kV) Pin Construction and LV ABC Suspension & Termination

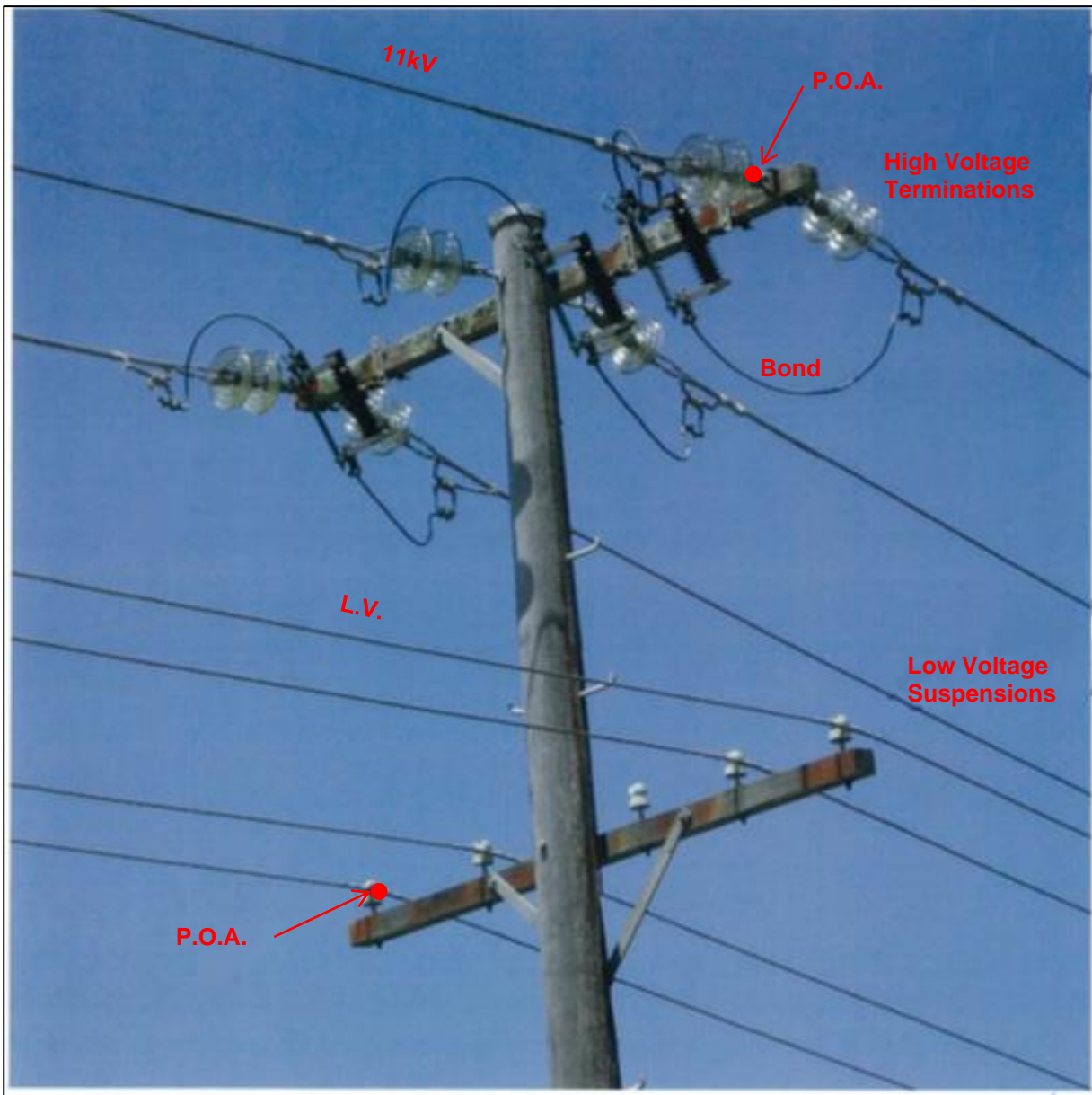

Figure B6: High Voltage (11kV) Terminations and Low Voltage Pins

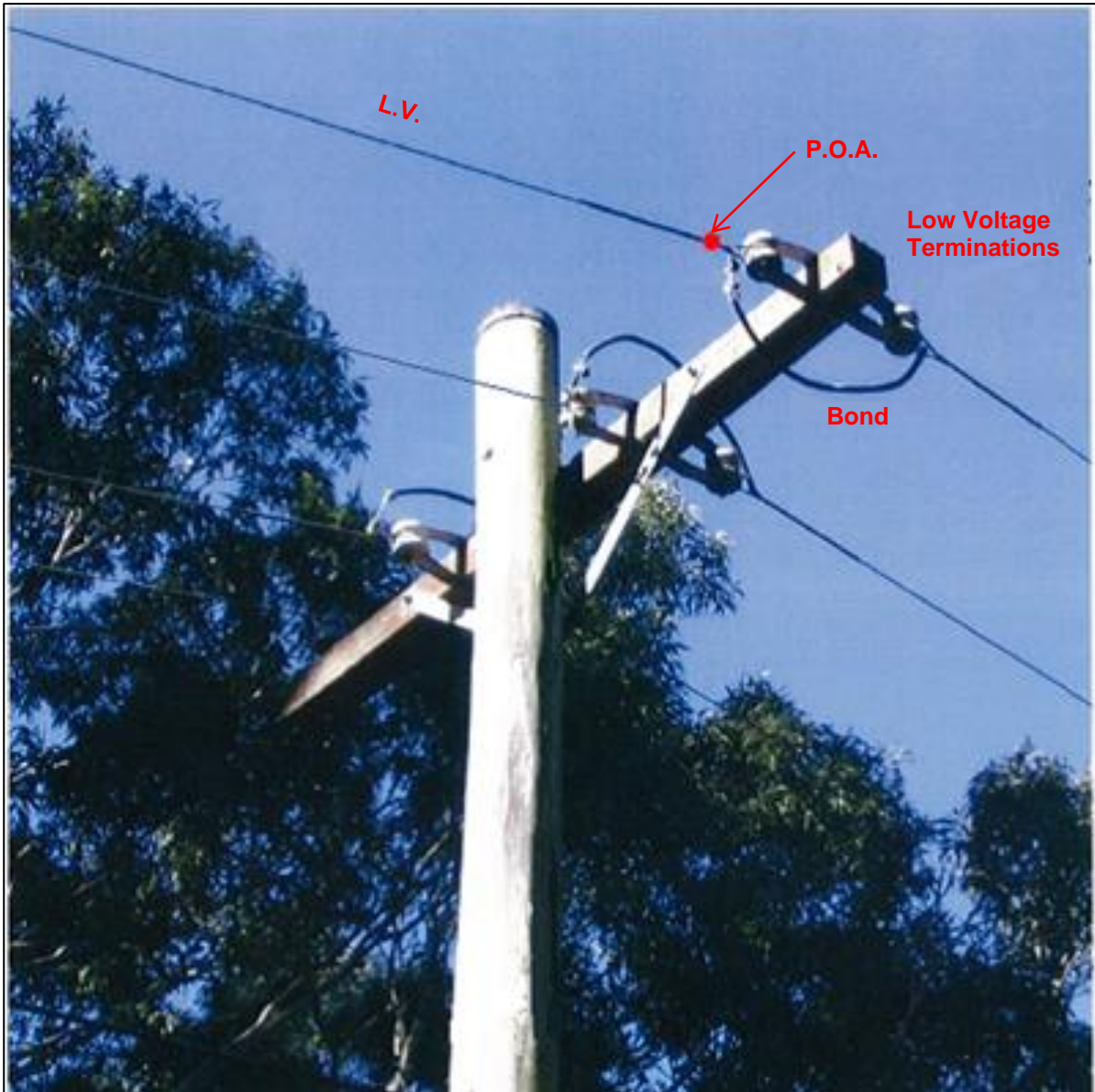

Figure B7: Low Voltage Terminations

Annexure C – Typical Waterway Crossing Span Design Drawing

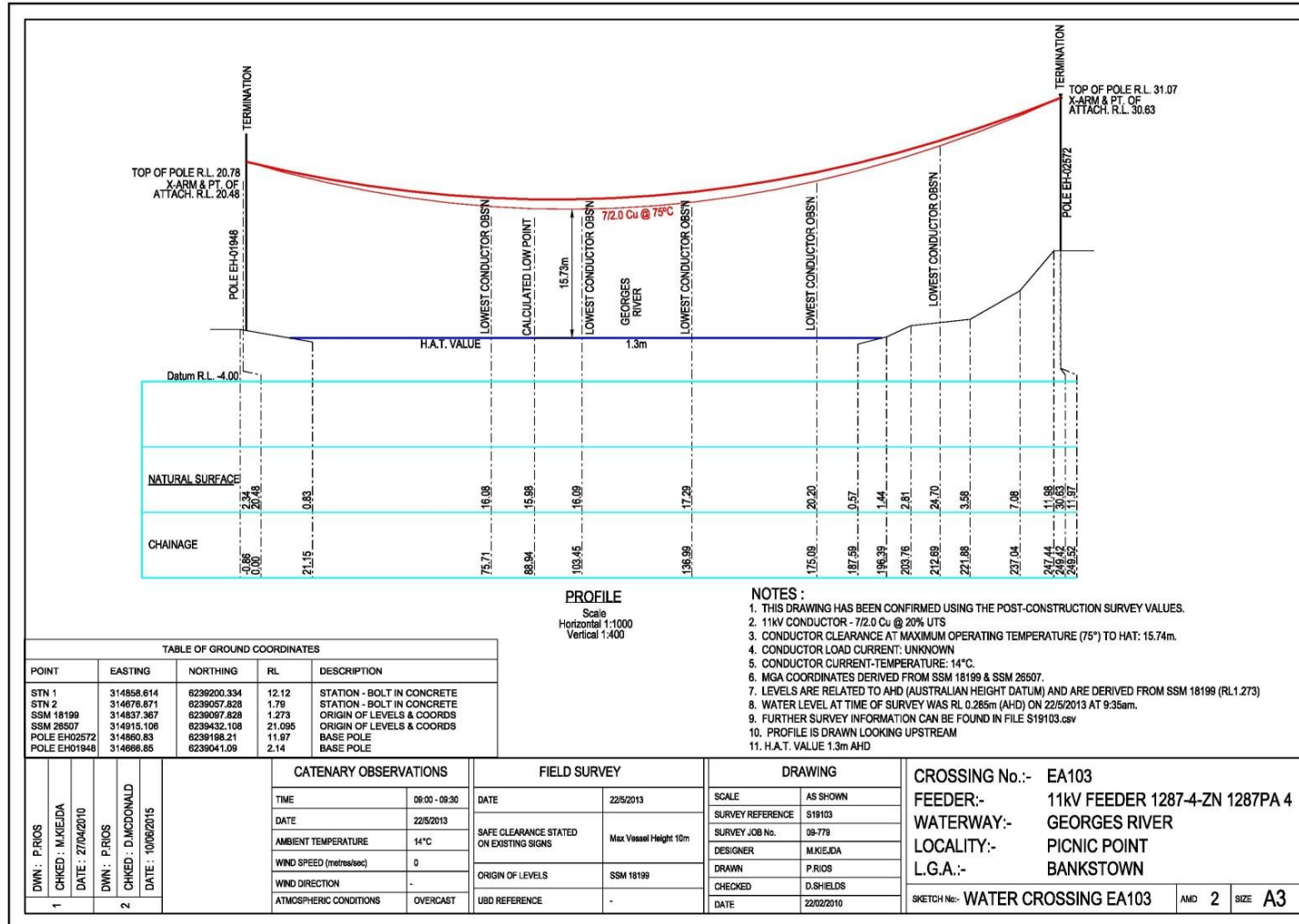

Figure C1 – Typical Waterway Crossing Span Design Drawing

Annexure D – List of Drawings

IMPORTANT: Users must ensure that the drawings they are using are the current versions with all amendments.

Table D1 – List of Drawings

Number	Title
237975	Standard Constructions – Signage Supports Structural Details
238007	Standard Constructions – Bi-Directional Sign Support Structural Details