

Network Standard

| | | | | | |
|--------------------|-----------------------------------|---------------|--|--------------|-------------------------------------|
| Document No. | Title: | | | | |
| NS126 | Construction of HV Overhead Mains | | | | |
| Approved Date | 1/08/2024 | Revision | 10 | | |
| Lifecycle Stage | Plan; Design; Construct | Internal Use | <input checked="" type="checkbox"/> | External Use | <input checked="" type="checkbox"/> |
| Technical Approver | | Authorised By | | | |
| Name | Duminda Thenuwara | Name | Murray Chandler | | |
| Designation | Senior Engineer | Designation | Head of Network Strategy & Future Grid | | |

Revision

| No | Date | Description | Technical Approver | Authorised By |
|----|------------|---|--------------------|-----------------|
| 6 | 09/05/2024 | Addition of Composite Fibre Crossarms | Matthew Cupples | Murray Chandler |
| 7 | 01/08/2024 | Addition of CCSX conductors. Conversion to new Network Standard template | Duminda Thenuwara | Murray Chandler |
| 8 | 21/11/2024 | Addition of ELBS drawings to Table A6 | Duminda Thenuwara | Jacob Bayley |
| 9 | 01/04/2025 | Removal of Drawing 228901 from Table A6 – superseded by drawing 170234. | Duminda Thenuwara | Jacob Bayley |
| 10 | 29/04/2026 | Drawing 224227 is superseded by Drawing 273251. Addition of drawings 273278 and 273290. | Duminda Thenuwara | Evan Riddell |

DISCLAIMER

This document is bound to the conditions set out in NS002 Network Standards Disclaimer.

Ausgrid maintains a copy of this and other Network Standards together with updates and amendments online at www.ausgrid.com.au. This document is considered uncontrolled once printed.

Table of Contents

| | |
|-------------------------------------|---|
| Scope | 3 |
| Reference Documents..... | 3 |
| Ausgrid Documents | 3 |
| Other Standards and Documents | 3 |
| 1 Introduction | 4 |
| 2 Selection | 4 |
| 3 Clearance criteria | 6 |
| 4 Construction | 7 |

List of Annexures

| | |
|---|----|
| Annexure A : Standard construction drawings | 16 |
|---|----|

Scope

This Network Standard and the standard construction drawings listed in Annexure A, describes Ausgrid's requirements for new construction and replacement or refurbishment of existing 11kV and 22kV High Voltage (HV) overhead mains.

Ausgrid's requirements for Low Voltage overhead mains are detailed in NS125 Construction of Low Voltage Overhead Mains. Ausgrid's requirements for sub-transmission overhead mains are detailed in NS135 Construction of Overhead 33kV, 66kV and 132kV Overhead Mains.

Ausgrid's requirements for overhead line design are detailed in NS220 Overhead Design Manual.

Reference Documents

All work covered in this document shall conform to all relevant Legislation, Standards, Codes of Practice and Network Standards.

Ausgrid Documents

NS116 Design Standards for Distribution Equipment Earthing

NS125 Construction of Low Voltage Overhead Mains

NS128 Pole Installation and Removal

NS129 11kV Joints and Terminations – Paper Insulated Lead Covered Cables

NS135 Construction of 33kV, 66kV and 132kV Overhead Mains

NS158 Labelling of Mains and Apparatus

NS167 Positioning of Poles and Lighting Columns

NS177 11kV Joints (including Transition Joints) & Terminations - Polymeric Insulated Cables

NS179 Vegetation Safety Clearances

NS214 Guide to Live Line Design Principles

NS220 Overhead Design Manual

NS268 Specification for Design and Construction of Waterway Crossings

Other Standards and Documents

AS1154 Insulator and conductor fittings for overhead power lines – Series

Clause Standard Requirements

1 Introduction

- 1.1 The high voltage overhead mains systems currently in use in the Ausgrid network are:
- Bare conductor,
 - Covered Conductor, and
 - High Voltage Aerial Bundled Cable (HV ABC).
- 1.2 No new SWER systems shall be constructed.
- 1.3 Details of bare conductor and covered conductors are documented in this Network Standard. For all proposed designs using HV ABC, the designer is required to refer these to Ausgrid for endorsement.

2 Selection

- 2.1 In selecting the type of mains, the designer shall follow the general design approach and conductor selection described in NS220.
- 2.2 Ausgrid reserves the right to nominate which overhead mains system to use in a given situation.
- 2.3 [Conductor selection](#)
- 2.3.1 [Bare conductors](#)
- 2.3.1.1 To minimise the range of fittings required, the conductors listed in Table 1 shall be used for new construction.

Table 1 - Mechanical Characteristics of Bare Conductor

| Conductor | Mercury | Pluto | Raisin | Apple | Cherry |
|--|---------|---------|----------|----------|-----------------|
| Ausgrid Stockcode | H13433 | H13459 | H13734 | H13467 | H13483 |
| Number of strands/wire diameter (mm) | 7/4.50 | 19/3.75 | 3/4/2.50 | 6/1/3.00 | 6/4.75 + 7/1.60 |
| Alloy type/grade | AAC | AAC | ACSR/GZ | ACSR/GZ | ACSR/GZ |
| Cross sectional area (mm²) | 111.3 | 209.8 | 34.36 | 49.5 | 120.4 |
| Diameter of conductor (mm) (approx.) | 13.5 | 18.8 | 7.5 | 9.0 | 14.3 |
| Mass (kg/m) (approx.) | 0.305 | 0.578 | 0.193 | 0.171 | 0.404 |

- 2.3.1.2 Many other conductors exist on the network, and they may continue to be used for minor work (such as replacement after a failure or pole relocation where a short extension to the mains is required). For current ratings and other electrical properties refer to NS220.
- 2.3.1.3 Where bare conductor is used, specific effort must be made during design and construction activities to avoid any possibility of conductor clashing throughout the life of the overhead line. Refer to Annexure A for construction types:
- Construction 2-5 (small delta) is the preferred construction for all intermediate structures.
 - Construction 2-1 is to be used only when under-building the circuit or for under-crossing structures.

- For longer spans, medium delta and large delta constructions are available and other construction types (e.g. horizontal offset) may be used under specific circumstances subject to Ausgrid's approval.

2.3.1.4 For offset constructions refer to Annexure A and NS167 Positioning of Poles and Lighting Columns.

2.3.2 Covered Conductors

Ausgrid currently uses two covered conductor types: CCT and CCSX. Conductor sizes are CCT80, CCT120, CCT180, CCSX25, CCSX62 and CCSX159. For current ratings and other electrical properties refer to NS220. Mechanical properties are shown in Table 2 and Table 3.

Table 2 - Mechanical Characteristics of CCT

| Conductor Cable Code | CCT80 | CCT120 | CCT180 |
|--|-----------|-----------|-----------|
| Ausgrid Stockcode | 184449 | 184451 | 184452 |
| Number of strands/wire diameter (mm) | 7/3.75 | 7/4.75 | 19/3.50 |
| Alloy type/grade | AAAC/1120 | AAAC/1120 | AAAC/1120 |
| Cross sectional area (mm²) | 77.3 | 124.0 | 182.8 |
| Diameter of conductor (mm) (approx.) | 11.4 | 14.5 | 17.7 |
| Insulation thickness (mm) (min. av.) | 3.4 | 3.4 | 3.4 |
| Diameter over covering (mm) | 18.8 | 21.9 | 25.0 |
| Mass (kg/km) (approx.) | 399 | 575 | 792 |
| Minimum bending radius (mm) | 280 | 330 | 375 |

Table 3 – Mechanical Characteristics of CCSX

| Conductor Cable Code | CCSX25 | CCSX62 | CCSX159 |
|---|--------|----------|---------|
| Ausgrid Stockcode | 186862 | 186861 | 186858 |
| Number of strands/wire diameter (mm) | 7/2.12 | 6/1/3.37 | 19/3.26 |
| Alloy type/grade | ACS | ACSR | AAAC |
| Cross sectional area (mm²) | 25 | 62 | 159 |
| Diameter of conductor (mm) (approx.) | 6.36 | 10.11 | 16.30 |
| Inner XLPE covering thickness (mm) (nom) | 1.32 | 1.32 | 1.32 |
| Outer HDPE covering thickness (mm) (nom) | 1.10 | 1.10 | 1.10 |
| Diameter over covering (mm) | 11.8 | 15.8 | 21.8 |
| Mass (kg/km) (approx.) | 250 | 340 | 642 |
| Minimum bending radius (mm) | 230 | 250 | 345 |

2.4 Crossarm selection

2.4.1 Crossarm material

2.4.1.1 Composite crossarms shall be used where they are included as an option on the standard construction drawing.

2.4.1.2 Some standard construction drawings do not include a composite crossarm in the length and drilling pattern required. In these cases, a timber or steel crossarm shall be used as shown on the standard construction drawing.

2.4.1.3 If steel crossarms are used, 33kV rated insulators shall be considered to meet insulation requirements as outlined in NS220.

2.4.2 Crossarm length

Crossarm lengths shall be chosen to meet design requirements such as midspan separation. The range of suitable crossarms is shown on each standard construction drawing.

2.5 Insulator selection

2.5.1 Insulator selection for all line types is specified in the standard construction drawings.

2.5.2 For CCT line construction, solid-core type pin post insulators shall be used.

2.5.3 For CCT lines, solid-core strain rod insulators and strain clamps shall be used at termination points and with high angle deviation ($>50^\circ$ for horizontal configuration or $>30^\circ$ for vertical configuration). The strain rod insulator currently available has a tongue and clevis designed to attach to a strain clamp.

2.6 Lightning protection for Covered Conductor

2.6.1 Surge arresters shall be installed at intervals of 500m or less.

2.6.2 Surge arresters shall be installed at covered conductor to bare conductor transition points. If the transition point is at an Air-Break Switch (ABS), the surge arresters shall be installed one span away from the ABS on the covered conductor side.

2.7 Lightning protection at switching locations

Surge arresters shall be earthed in accordance with NS116 Design Standards for Distribution Earthing and shall be designed and constructed in accordance with the relevant standard construction drawings listed in NS116.

2.8 Earthing points

2.8.1 Earthing points shall be established at all points where it is envisaged that access permit earths or working earths may be required. At a minimum, these locations are on either side of pole mounted 11kV switches, PTs, 11kV UGOHs, surge arresters and on tee-offs. Earthing points shall be installed at locations where earths can be installed and removed without requiring extensive traffic control.

2.8.2 Where pole mounted equipment requires that access permit earths or working earths be installed from an elevating work platform, they shall be placed at least one metre from the vertical projection of the nearest energised conductor. To accommodate this, the earthing point shall be established at least one metre from the dropper cable.

3 Clearance criteria

3.1 All clearances shall be met at the time the network is built or altered in any way, including construction of new lines, pole replacements or relocations, conductor replacements and crossarm replacements. This includes the clearances to ground and structures specified in NS220 and the vegetation clearances in NS179 Vegetation Management.

3.2 For live-line design principles refer to NS214 Guide to Live Line Design Principles.

4 Construction

Lines shall be constructed in accordance with the standard construction drawings listed in Annexure A.

4.1 Conductor stringing

The two principle methods of line erection are paying-out and pulling-in. Of the two, pulling-in is the preferred method as it minimises the likelihood of damage to the conductor during the installation process.

4.2 Phasing

4.2.1 The configuration of phases shall be according to the particular installation requirements as specified in the design. Where there are no installation constraints, the following configuration shall be used:

- Phase A: Bottom conductor or footpath / property side
- Phase B: Centre conductor
- Phase C: Top conductor or road side

4.3 Clearances and spacing

4.3.1 Phase-to-phase spacing for covered conductors

4.3.1.1 For new construction, the minimum phase-to-phase spacing between conductors shall be 500mm. This shall apply at the structures as well as midspan.

4.3.1.2 Interphase clearance must be strictly adhered to. Small deviations will cause a reduction in Basic Insulation Level resulting in a decrease in performance of the line.

4.3.2 Line stagger for conductor

For horizontal pin insulator construction (2-1 and 2-1CCSX), the centre conductor is staggered by orienting the centre pin insulator on opposite sides of each successive pole as shown in Figure 1 - Line stagger. This maximises the mid-span separation between conductors.

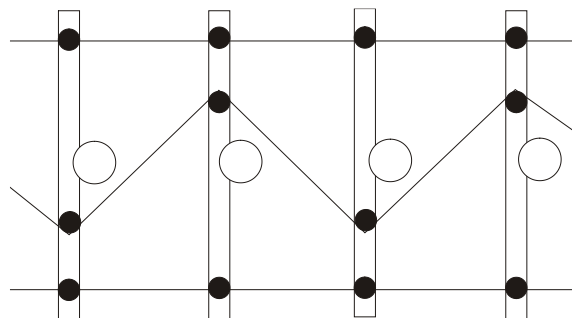

Figure 1 - Line stagger

4.3.3 Separation between HV and LV

4.3.3.1 The separation between HV and LV circuits at the pole depends on whether the HV network is intended to be worked on using live-line techniques.

4.3.3.2 Air-break switch designs shall assume the use of live-line techniques and the live-line clearances of NS220 apply.

4.3.3.3 Spur lines shall be designed and constructed with live-line circuit to circuit separations.

4.3.3.4 CCT is not maintained with live-line techniques and the non-live-line clearances of NS220 apply.

4.4 [Railway crossings](#)

Where poles are positioned near a rail corridor, they shall meet the requirements of NS167.

4.5 [Navigable waterway crossings](#)

Where a section of line crosses a navigable waterway, it shall meet the requirements of NS268.

4.6 [Pole Installation and removal](#)

Refer to NS128, NS167 and NS220.

4.7 [Staying of poles](#)

Where poles are required to be stayed, they shall meet the requirements of NS220.

4.8 [11kV UGOH constructions](#)

4.8.1 HV UGOH constructions shall be constructed in accordance with the requirements of:

- NS177 11kV Joints (including Transition Joints) & Terminations - Polymeric Insulated Cables, or
- NS129 11kV Joints and Terminations – Paper Insulated Lead Covered Cables.

4.8.2 UGOHs shall be labelled in accordance with NS158 Labelling of Mains and Apparatus.

4.8.3 Earthing requirements for UGOHs are specified in NS116.

4.9 [Covered conductor precautions](#)

4.9.1 The following precautions shall be taken when working with covered conductor:

- When pulling in cables take care not to damage the covering.
- Never bend the cable tighter than the minimum bending radius.
- Do not drop the cable or drag it along the ground or over any obstacle.
- Do not let the cable rub against poles.
- Where the covering is to be removed, it shall be removed using tools and procedures specifically designed for this purpose. The conductor shall not be damaged during stripping. The use of incorrect tools and procedures can lead to premature failure of the conductor, so any conductor damage shall be cut out and the conductor repaired.
- The covering shall not be removed at the pin or post insulator.

4.9.2 Additional installation precautions for CCSX:

- Check/tighten drum bolts after transport and before pulling.
- Loosen inner end and allow to “grow” during pulling, cut off the end if it interferes with drum rotation – see Amokabel Information Sheet “CCSX Drum – Inner End Protrusion”.

4.10 [Covered conductor covering integrity](#)

4.10.1 To maintain the integrity of the system, it is essential the covering is restored at all points where the covering is stripped or punctured.

4.10.2 Special purpose covers shall be installed correctly on each piece of hardware, such as electrical connections and mechanical terminations.

4.11 [Covered conductor water-blocking compound](#)

4.11.1 Water-blocking compound is used to prevent the migration of water along the inside of the conductor. The water blocking fills the interstices between strands and the space between the aluminium conductor surface and the covering.

4.11.2 The water-blocking between the outer strands shall be removed when stripping the conductor to make electrical connections.

4.12 [CCT fittings and insulating covers](#)

CCSX fittings are not suitable for use on CCT.

4.12.1 Strain clamp and cover for CCT

Strain clamp stockcodes are given in the table below.

Table 4 - Ausgrid Strain Clamp Stockcodes

| CCT Cable | Strain Clamp | Strain Clamp Cover |
|--------------------|--------------|--------------------|
| 80mm ² | 144535 | 144543 |
| 120mm ² | 144527 | 144543 |
| 180mm ² | 176313 | 181248 |

4.12.2 Parallel groove clamp and cover for CCT

4.12.2.1 Parallel Groove (PG) clamps shall be used to make non-tension connections between conductors. The connectors accommodate the following range of conductor sizes:

- Main conductor: 7/3.75 to 19/3.50 (CCT80, CCT120, CCT180)
- Tapping conductor: 7/3.75 to 19/3.50 (CCT80, CCT120, CCT180)

Table 5 – Ausgrid CCT PG Clamp Stockcodes

| PG Clamp | PG Clamp Cover |
|----------|----------------|
| 62414 | 144576 |

4.12.3 Standard earthing point and cover for CCT

Standard earthing points are created by removing 125mm of the insulation on the CCT at each nominated point. An earthing point cover shall be installed at each earthing point. The cover is moved along the conductor to reveal the earthing point by tapping with an earthing stick. The cover must be returned to its correct position after removal of the earths. The stockcode for the earthing point cover is 144741.

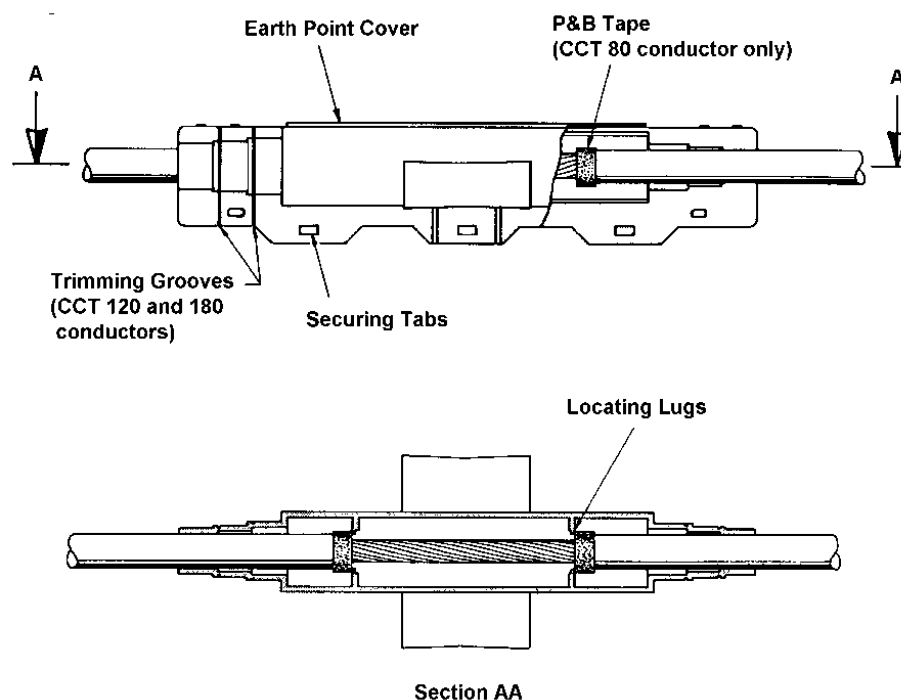

Figure 2 - Earth Point Cover

4.12.4 Full tension joint for CCT

4.12.4.1 Full tension joints shall only be used to join conductors that are the same size and type.

4.12.4.2 When more than one phase is joined in a span, joint positions of different phases shall be offset by at least 1m.

Table 6 - Ausgrid Full Tension Joint Stockcodes

| CCT Cable | Full Tension Joint sleeve | Mastic coated heatshrink tube |
|--------------------|---------------------------|-------------------------------|
| 80mm ² | 144733 | Supplied with sleeve |
| 120mm ² | 144725 | Supplied with sleeve |
| 180mm ² | 176321 | Supplied with sleeve |

4.12.5 Tie wires

4.12.5.1 Tie wires for CCT

Three tie wire sizes are available for CCT, one to match each conductor size, with colour coded end caps identifying each size. Bare tie wires shall not be used on CCT due to the risks with electrical tracking and degradation of the CCT insulation.

Table 7 - Ausgrid Tie Wire for CCT Stockcodes

| CCT Cable | Tie Wire |
|--------------------|----------|
| 80mm ² | 144618 |
| 120mm ² | 144600 |
| 180mm ² | 176312 |

4.13 CCSX fittings

4.13.1 General

4.13.1.1 CCSX has been designed and tested as a complete system and shall be used with the proper fittings.

4.13.1.2 CCSX has a 3-layer construction with different dimensions and materials than CCT, and therefore CCT fittings shall not be used on CCSX.

4.13.1.3 CCSX fittings are intended to minimise stripping requirements in order to streamline construction works, reduce costs and increase reliability.

4.13.1.4 All metallic components are bonded to the conductor to reduce electric stress and tracking, and each fitting has an overall covering to prevent contact with vegetation and wildlife.

4.13.1.5 All fittings shall be installed as per the manufacturer's instructions and using only the materials included in the kits.

4.13.1.6 CCSX fitting stockcodes are listed individually below and can also be found in SAP or the AML by searching or filtering for "CCSX", "CCSX25" etc.

4.13.2 Endcaps

All cut ends shall be sealed with the specified coldshrink endcaps to prevent water ingress and corrosion, this includes bonds, terminations and cable cut at the drum. A 200mm section of free cable is needed in order to apply the endcap.

Endcaps are given in the table below:

Table 8 - Endcaps for CCSX Stockcodes

| CCSX Cable | Endcap |
|--------------------------|--------|
| CCSX159 | 186887 |
| CCSX62 and CCSX25 | 186886 |

4.13.3 CCSX159 and CCSX62 deadends

4.13.3.1 Terminations for CCSX159 and CCSX62 conductors use a wedge clamp deadend that grips onto the covering, similar to OPGW deadends.

4.13.3.2 Two IPCs are used to bond the metallic components to the conductor, and these IPCs also assist with the tensile strength of the clamp.

4.13.3.3 The two IPCs shall be tightened in turn to the specified torque steps using a manual torque wrench until the shearbolts snap off. Two threaded rods give 100mm of adjustment for tensioning purposes.

Table 9 - Deadends and cover for CCSX Stockcodes

| CCSX Cable | Deadend | Cover |
|----------------|---------|--------|
| CCSX159 | 186867 | 186871 |
| CCSX62 | 186868 | 186872 |
| CCSX25 | 186870 | 186873 |

4.13.3.4 Tensioning must be carried out using the correct come-alongs and jaws as specified by the supplier.

4.13.4 CCSX25 deadend

4.13.4.1 Due to the small diameter and high tensile strength of the aluminium-coated steel conductor, terminations for CCSX25 conductor use a compression deadend.

4.13.4.2 The covering shall be stripped to a length equal to the internal depth of the compression deadend plus 20mm to allow the deadend to grow during compression.

4.13.4.3 A 60 tonne press head and 16mm A/F hexagonal steel dies shall be used to crimp starting at the knurl mark nearest the eye.

4.13.4.4 Crimps with 50% overlap shall be made to the end of the deadend, with 10-12 crimps being needed. The through-connection is via an IPC and bond.

4.13.4.5 The high tensile strength also requires tensioning using an MRP 4 bolt pocketbook clamp instead of come-alongs. It is vital that the manufacturer's instructions are followed in relation to bolt tightening order and torque to avoid damage to the covered conductor. The MRP 4-bolt pocketbook clamp shall be attached at least 3 metres away from the intended position of the compression deadend and has a maximum tension limit of 15.6kN (50% of CCSX25 breaking strain).

4.13.4.6 At locations where stringing tension is expected to be low ($\leq 2\text{kN}$) CCSX tensioning can be achieved using helical pole ties instead of the MRP 4 bolt pocketbook clamp.

- 4.13.4.7 Due to manual handling constraints with the heavy press head, CCSX25 compression deadends are constrained in where they can be fitted:
- Not on a pole platform.
 - At the drum, with the compression deadend being carefully pulled through suitable rollers – refer to Amokabel Information Sheet “Hauling CCSX25 with a CDE”.
 - On the ground.
 - In EWP bucket, using suitable bench as per an approved risk assessment.

4.13.4.8 The project design shall be carried out to account for these constraints so that compression deadends can be installed safely at both ends and that tensioning via the MRP 4 bolt pocketbook clamp can be achieved in a safe and practical manner.

4.13.5 CCSX IPCs

4.13.5.1 Insulation-Piercing Connectors (IPCs) are used for most CCSX connections.

4.13.5.2 IPCs must never be removed otherwise this leaves a path for water ingress and corrosion – instead if a particular connection is no longer needed the bond shall be cut away and capped, and a new IPC installed nearby if still needed.

4.13.5.3 IPCs use shearbolts that can be tightened using a battery-power impact wrench on Slow setting.

4.13.5.4 IPCs shall be installed horizontally for bond connections.

4.13.5.5 The minimum distances between IPCs and other fittings are shown in Table 10.

Table 10 – Minimum distances from other fittings

| Fitting | Minimum distance (in mm) |
|---------------|--------------------------|
| Insulator tie | 50 |
| Deadend | 300 |
| Other IPC | 50 |

4.13.5.6 Two types of IPCs are available as shown in Table 11, depending on whether the CCSX is connected to a bare conductor another CCSX cable.

Table 11–IPCs for CCSX stockcodes

| Conductor | IPC |
|---|--------|
| Covered-covered, suitable for CCSX25, CCSX62 and CCSX159 on both sides in any combination. | 186863 |
| Covered-bare, suitable for CCSX25, CCSX62 and CCSX159 on one side and 16-241mm ² aluminium or copper bare conductor on the other side. | 186864 |

4.13.6 CCSX EPDs

- 4.13.6.1 EPDs (Earth Parking Devices) comprise a tinned copper earth stirrup for the connection of portable earths. The tinned copper earth stirrup has an insulated end that is attached using a covered-covered IPC.
- 4.13.6.2 IPCs shall be installed vertically for EPD connections.
- 4.13.6.3 The exposed end of the tinned copper earth stirrup comes with a silicone rubber cap that can be removed and reinstated with a hotstick. These caps shall be kept near the base of the pole when removed, however the feeder can be energised safely if the cap is missing or lost.

Table 12 – EPD for CCSX Stockcodes

| CCSX Cable | EPD |
|------------|--------|
| All sizes | 186865 |

4.13.7 Surge arrester connections

Surge arresters shall be the same as used for bare conductors. The surge arresters are attached via a bond, a covered-covered IPC, and a lightning arrester connection that can be disconnected and reconnected in the event of a surge arrester failure, hence avoiding the need for a new IPC.

Table 13 – Lightning arrester connection for CCSX Stockcodes

| CCSX Cable | Connection |
|------------|------------|
| All sizes | 186866 |

4.13.8 Insulator ties

- 4.13.8.1 Insulator tie sets are given in the table below.

Table 14 – Insulator tie stockcodes

| Cable size | Insulator tie |
|------------|---------------|
| CCSX159 | 186874 |
| CCSX62 | 186875 |
| CCSX25 | 186876 |

- 4.13.8.2 The ties shall be applied as normal bare ties, including tying to the side of the pin insulator for angled alignment.

4.13.9 Vibration dampers

- 4.13.9.1 Helical/spiral vibration dampers are given in the table below.

Table 15 – Vibration dampers stockcodes

| Cable size | Vibration damper |
|------------|------------------|
| CCSX159 | 186883 |
| CCSX62 | 184142 |
| CCSX25 | H92486 |

- 4.13.9.2 Vibration dampers shall be fitted at least 300mm from a deadend or IPC.

4.13.10 Midspan splices

4.13.10.1 Midspan splices shall only to be used for repairs, not during initial installation. Different size CCSX cables cannot be joined midspan; size changes shall be achieved at a termination pole. Midspan splices shall be made in-situ and not be pulled through rollers.

Full-tension splices are given in the Table 16.

Table 16 – Midspan splices stockcodes

| Cable size | Splice |
|----------------|--------|
| CCSX159 | 186879 |
| CCSX62 | 186880 |

4.13.10.2 The splices for CCSX159 and CCSX62 use internal wedges to grip the stripped conductor with an overall coldshrink cover to prevent water ingress.

4.13.10.3 The CCSX25 splice is a compression type that shall be installed the same as the CCSX25 compression deadend. The coldshrink cover is a separate item and shall be used.

Table 17 – Midspan splices stockcodes

| Cable size | Splice | Cover |
|---------------|--------|--------|
| CCSX25 | 186881 | 186882 |

4.13.11 Pole changeovers with existing CCT

For pole replacements where the pole already has CCT installed – if the conductor length needs to be extended it shall be achieved by splicing in a new short section of CCT.

4.14 Other fittings and joint preparation

4.14.1 Tie wires for bare conductor

Tie wire for bare conductor shall be in accordance with drawing 514038 to suit the conductor used.

4.14.2 Sleeves and compression lugs for bare conductor

Compression lugs, full tension sleeves, and non-tension sleeves shall be installed in accordance with the manufacturer's instructions, particularly the tooling used (e.g. versa crimp or hexagonal die) and number of crimps.

4.14.3 Preparation for joints

4.14.3.1 Aluminium connectors that are not supplied with factory applied jointing compound shall be wire-brushed and coated with a jointing compound just before the connection is made.

4.14.3.2 Joint compound used with aluminium connections shall seal out air and moisture, minimising oxidation or corrosion and maximising conductivity. In certain applications it shall contain conductive (zinc) particles within the compound to penetrate oxide films that form on the aluminium surfaces.

4.14.3.3 Prior to making copper connections, oxide coatings shall be thoroughly removed using either emery paper or a wire brush. An oxide-inhibiting and moisture-proofing Type 1 jointing compound shall then be applied immediately to the contact surfaces.

4.14.3.4 Aluminium conductors shall be prepared with an aluminium wire brush.

4.14.3.5 Copper conductors shall be prepared with a copper wire brush.

4.15 Angle of deviation specifications for CCT

Table 18 - Angle of Deviation Specifications

| Angle of Deviation | Required Construction |
|---|---|
| Vertical construction 0° - 10° deviation | Post insulator on bracket. (stockcode: 144626) |
| Vertical construction 10° - 30° deviation | Post insulator on angle bracket. (stockcode: 144634) |
| Vertical construction > 30° deviation | Strain clamp and strain rod arrangement. |
| Horizontal construction 0° - 25° deviation | Pin post (single crossarm). |
| Horizontal construction 25° - 50° | Pin post (double crossarm). |
| Horizontal construction > 50° | Strain clamp and strain rod arrangement. |
| Delta Construction 0° - 25° deviation | Post insulators on single crossarm and one pole raiser. |
| Delta Construction 25° - 50° deviation | Post insulators on double crossarms and two pole raisers. |
| Delta Construction > 50° deviation | Strain clamp and strain rod arrangement. |

4.16 Pole-top operating devices

4.16.1 Pole-top operating devices shall be located and oriented so that they can be safely operated. When installed next to a road, the operating mechanism shall be installed such that they can be operated by standing on the side of the pole away from the road wherever practical.

4.16.2 On CCT lines, standard earthing points and covers shall be provided on both sides of each operating device.

4.17 Air break switches

4.17.1 Air Break Switches (ABSs) and their operating mechanisms shall be installed such that no pole attachments are less than 3.6m above ground level.

4.17.2 All ABSs shall be mounted on poles in accordance with Drawing Nos. 175902 and 255645.

4.18 Redundant mains and hardware

4.18.1 Where overhead mains are redundant, the designer shall make provision in the design to remove redundant assets when work is identified on the pole structure.

4.18.2 All redundant hardware, including connectors, shall be removed at the time it is made redundant. Any other redundant hardware already present shall also be removed.

Annexure A: Standard construction drawings

Table A1 - CCT Conductor Standard Construction Drawings

| Description | Construction Number | Drawing Number |
|---|---------------------|----------------|
| 11kV Horizontal Pin Construction | 2-1CCT | 174956 |
| 11kV Offset Arm Construction | 2-2CCT | 174957 |
| 11kV ¾ Offset Arm Construction | 2-4CCT | 175880 |
| 11kV Small Delta Construction | 2-5CCT | 174958 |
| 11kV Delta Construction | 2-6CCT | 174959 |
| 11kV Large Delta Construction | 2-7CCT | 174960 |
| 11kV Termination Construction | 2-10CCT | 174961 |
| 11kV Through Termination Construction | 2-11CCT | 174962 |
| 11kV Corner Pole Termination Construction | 2-12CCT | 174963 |
| 11kV Tee-Off Construction | 2-14CCT | 174964 |
| 11kV Large Through Delta Termination Construction | 2-30CCT | 174965 |
| 11kV Large Delta Corner Construction | 2-31CCT | 174966 |
| 11kV Large Through Delta Termination with Tee-Off Construction | 2-37CCT | 174967 |
| 11kV Large Delta with Tee-Off Construction | 2-38CCT | 174968 |
| 11kV Through Termination Construction with Dropout Fuses or Isolating Links | 2-60CCT | 175886 |
| 11kV Tee-Off Construction with Dropout Fuses or Isolating Links | 2-61CCT | 175887 |
| 11kV Horizontal Pin Twin Crossarm Construction | 2-101CCT | 175883 |
| 11kV Delta Twin Crossarm Construction | 2-106CCT | 175884 |
| 11kV Large Delta Twin Crossarm Construction | 2-107CCT | 175885 |
| 11kV Vertical Termination Construction | 2-140CCT | 163265 |
| 11kV Vertical 4 Way Termination Construction | 2-142CCT | 175878 |
| 11kV Vertical Through Termination with Tee Off Construction | 2-146CCT | 163144 |
| 11kV Delta Pin Post Construction | 2-200CCT | 163146 |
| 11kV Vertical Pin Post Construction | 2-240CCT | 163145 |
| 11kV Vertical Pin Post with Tee Off Construction | 2-242CCT | 175876 |
| 11kV Vertical Pin Post 4 Way Crossover Construction | 2-243CCT | 175877 |
| 11kV Distribution Vertical CCT to UGOH Connection Assembly | - | 167676* |
| Standard Construction 11kV CCT Surge Arrester Arrangements | - | 177151 |

* Only with approval from Ausgrid.

Table A2 - CCSX Conductor Standard Construction Drawings

| Description | Construction Number | Drawing Number |
|---|---------------------|----------------|
| 11kV Horizontal Pin Construction | 2-1CCSX | 265885 |
| 11kV Offset Arm Construction | 2-2CCSX | 265886 |
| 11kV ¾ Offset Arm Construction | 2-4CCSX | 265887 |
| 11kV Small Delta Construction | 2-5CCSX | 265888 |
| 11kV Termination Construction | 2-10CCSX | 265889 |
| 11kV Through Termination Construction | 2-11CCSX | 265890 |
| 11kV Corner Pole Termination Construction | 2-12CCSX | 265891 |
| 11kV Tee-Off Construction | 2-14CCSX | 265892 |
| 11kV Vertical Termination Construction | 2-140CCSX | 265893 |
| 11kV Vertical Through Termination with Tee Off Construction | 2-146CCSX | 265894 |
| 11kV Delta Pin Post Construction | 2-200CCSX | 265895 |
| 11kV Vertical Pin Post Construction | 2-240CCSX | 265896 |
| 11kV Vertical Pin Post with Tee Off Construction | 2-242CCSX | 265897 |
| 11kV CCSX Surge Arrester arrangement | - | 265905 |

Table A3 - CCT to Bare Conductor Standard Construction Drawings

| Description | Construction Number | Drawing Number |
|---|---------------------|----------------|
| 11kV CCT to Bare Conductor Through Termination Construction | 2-411 | 154233 |
| 11kV CCT to Bare Conductor Corner Pole Termination Construction | 2-412 | 154234 |
| 11kV Bare Conductor to CCT Tee-Off Construction | 2-414 | 154235 |
| 11kV CCT to Bare Conductor Large Delta Through Termination Construction | 2-430 | 154236 |
| 11kV CCT to Bare Conductor Large Delta Corner Construction | 2-431 | 154237 |
| 11kV Bare Conductor Large Through Delta Termination with CCT Tee-Off Construction | 2-437 | 154238 |
| 11kV Bare Conductor Large Delta with CCT Tee-Off Construction | 2-438 | 154239 |
| 11kV CCT to Bare Conductor Vertical Termination Construction | 2-4140 | 177229 |
| CCT Fittings: Overhead Line Compression Fittings Index | | 514053 |

Table A4 - CCSX to Bare Conductor Standard Construction Drawings

| Description | Construction Number | Drawing Number |
|---|---------------------|----------------|
| 11kV CCSX to Bare Conductor Through Termination Construction | 2-411CCSX | 265898 |
| 11kV CCSX to Bare Conductor Corner Pole Termination Construction | 2-412CCSX | 265899 |
| 11kV CCSX to Bare Conductor Vertical through Termination Construction | 2-4140CCSX | 265900 |

Table A5 – CCSX to CCT Conductor Standard Construction Drawings

| Description | Construction Number | Drawing Number |
|---|---------------------|----------------|
| 11kV CCSX to CCT Conductor Through Termination Construction | 2-511CCSX | 273278 |

Table A6 - Bare Conductor Lines Standard Construction Drawings

| Description | Construction Number | Drawing Number |
|--|-----------------------|----------------|
| 11kV Constructions | | |
| 11kV Flat Pin Construction | 2-1 | 513909 |
| 11kV Offset Arm Construction | 2-2 | 513910 |
| 11kV Angle Suspension Construction | 2-3 | 513911 |
| 11kV ¾ Offset Arm Construction | 2-4 | 175879 |
| 11kV Small Delta Construction | 2-5 | 513912 |
| 11kV Delta Pin Construction (see note) | 2-6 | 520222 |
| 11kV Large Delta Pin Construction (see note) | 2-7 | 513913 |
| 11kV Horizontal Pin Construction with ABS and UGOH Arrangement | - | 166585* |
| 11kV Termination Construction with ABS and UGOH Arrangement located behind termination | - | 166590* |
| 11kV Termination Construction with ABS and UGOH Arrangement located under termination | - | 166595* |
| 11kV Termination Construction | 2-10 | 513914 |
| 11kV Through Termination Construction | 2-11 | 513915 |
| 11kV Through Transposition Termination Construction | 2-11 Transposition | 273290 |
| 11kV Corner Pole Termination | 2-12 | 513916 |
| 11kV Tee-off Construction | 2-14 | 513917 |
| 11kV Railway Termination RHS Galv. Crossarm | 2-23 | 513918 |

| Description | Construction Number | Drawing Number |
|---|---------------------|----------------|
| 11kV Large Through Delta Termination Construction | 2-30 | 513919 |
| 11kV Large Delta Corner Construction (see note) | 2-31 | 513943 |
| 11kV Large Through Delta Termination with tee-off construction (see note) | 2-37 | 514180 |
| 11kV Large Delta with tee-off construction (see note) | 2-38 | 520410 |
| 11kV Through Termination Construction with Drop-out Fuses or Isolating Links | 2-60 | 514007 |
| 11kV Tee-Off Construction with Drop-out Fuses or Isolating Links | 2-61 | 513895 |
| 11kV Vertical Termination Construction | 2-140 | 175875 |
| 11kV Vertical 4 Way Termination Construction | 2-142 | 244675 |
| 11kV Vertical Through Termination with Tee Off | 2-146 | 251941 |
| 11kV Vertical Delta Construction | 2-200 | 183908 |
| 11kV Vertical Construction | 2-240 | 183907 |
| 11kV Pole Top Capacitors Construction Detail | | 162475 |
| Standard Construction Pole Top Regulator Ground Mounted Fibreglass Cabinet Concrete Footing Details | | 191227 |
| Standard Construction 11kV Underground to Overhead Construction Details | | 160354 |
| 22kV Constructions | | |
| 22kV Horizontal Pin Construction | 3-1 | 513993 |
| 22kV Small Delta Construction | 3-5 | 513994 |
| 22kV Delta Construction | 3-6 | 258023 |
| 22kV Large Delta Construction | 3-7 | 255617 |
| 22kV Termination Construction | 3-10 | 513991 |
| 22kV Through Termination Construction | 3-11 | 513992 |
| 22kV Corner Pole Termination Construction | 3-12 | 255618 |
| 22kV Large Through Delta Termination | 3-30 | 255619 |
| 22kV Through Termination Construction with Dropout Fuses or Isolating links | 3-60 | 255643 |
| 22kV Tee-Off Construction with Dropout Fuses or Isolating links | 3-61 | 255644 |
| 22kV Vertical Termination Construction | 3-140 | 184959 |
| 22kV Vertical Delta Construction | 3-200 | 184958 |
| 22kV Vertical Construction | 3-240 | 184957 |
| Bare Conductor Fittings | | |
| Overhead Line Compression Fittings Index | | 514053 |

| Description | Construction Number | Drawing Number |
|---|---------------------|----------------|
| Standard Construction 11/22kV Aerodynamic Insulator and Pin Arrangement | | 513997 |
| Standard Construction 11kV Longrod Insulator String Arrangement | | 565715 |

* Only with approval from Ausgrid.

Note: Constructions 2-6, 2-7, 2-31, 2-37, 2-38 are for use with long spans only.

Table A7 – Pole Mounted Equipment Standard Construction Drawings

| Description | Construction Number | Drawing Number |
|--|---------------------|----------------|
| Standard Construction 2 Unit 11kV Pole Mounted Regulator with Ground Mounted Control Panel | | 224401* |
| Standard Construction 3 Unit 11kV Pole Mounted Regulator with Ground Mounted Controllers | | 224229* |
| Standard Construction 11kV S&C IntelliRupter Pulse closer without Bypass Air Break Switch | | 220041* |
| Standard Construction 11kV S&C IntelliRupter Pulse closer Controlling Pole Mounted Regulators | | 224228* |
| Standard Construction 11kV S&C IntelliRupter Pulse closer with By-Pass Air Break Switch General Arrangement | - | 220251* |
| Standard Construction 11kV Pole Mounted Regulator with Controlling NOJA type OSM15 Recloser General Arrangement | | 273251 |
| Standard Construction 11kV S&C IntelliRupter Pulse closer with phase to phase VT mounted on a Composite pole General Arrangement | | 244230 |
| Standard Construction 11kV S&C IntelliRupter Pulse closer with phase to phase VT mounted on a Composite pole - Pole drilling details | | 244231 |
| Standard Construction 2 Unit 11kV Pole Mounted Regulator with Pole Mounted Control Panel | | 224402* |
| 11kV INSULECT Mid Pole Operated Air Break Switch for Timber, Composite, Concrete & Steel Poles | 2-455 | 175902-1 |
| 11kV NGK Mid Pole Operated Air Break Switch for Timber, Composite, Concrete & Steel Poles | 2-455 | 175902-2 |
| 22kV INSULECT Mid Pole Operated Air Break Switch for Timber, Composite, Concrete & Steel Poles | 3-455 | 255645-1 |
| 22kV NGK Mid Pole Operated Air Break Switch for Timber, Composite, Concrete & Steel Poles | 3-455 | 255645-2 |
| Standard Construction 11kV NOJA Type OSM15 Recloser with By-Pass Air Break Switch Mounted on a timber pole General Arrangement | | 255677 |
| Standard Construction 11kV NOJA OSM15 Recloser Mounted on a Timber Pole General Arrangement | | 258068 |

| | | |
|--|--|--------|
| Standard Construction 11kV Schneider RL series pole mounted enclosed switch mounted over ABC LV mains General Arrangement | | 170234 |
|--|--|--------|

* Only with approval from Ausgrid.